

**BEFORE THE HON'BLE CENTRAL ELECTRICITY REGULATORY COMMISSION,
NEW DELHI**

PETITION NO. ____/AT/2024

IN THE MATTER OF:

Petition under Section 63 of Electricity Act, 2003 seeking adoption of Transmission Charges of the "Western Region Network Expansion Scheme in Kallam area of Maharashtra" being established by the Petitioner.

AND IN THE MATTER OF:

Kallam Transco Limited

...PETITIONER

Versus

REC Power Development and
Consultancy Ltd. and Anr.

...RESPONDENTS

INDEX

S. No.	Particulars	Page Nos.
1.	Memo of Parties	1
2.	Application under Section 63 of Electricity Act, 2003 seeking adoption of Transmission Charges of the "Western Region Network Expansion Scheme in Kallam area of Maharashtra" being established by the Petitioner along with supporting Affidavit	2-17
3.	Annexure P-1: A copy of the Certificate of Incorporation of the Petitioner/Applicant Company.	18
4.	Annexure P-2 (Colly.): Copies of the Memorandum of Association & Articles of Association of the Petitioner/Applicant Company	19-48
5.	Annexure P-3: A copy of the Minutes of Meeting of 14 th NCT meeting	49-125

S. No.	Particulars	Page Nos.
6.	Annexure P-4: A copy of the Gazette Notification dated 19.07.2023 issued by MoP, Gol.	126-127
7.	Annexure P-5 : A copy of the RfP dated 13.10.2023	128-275
8.	Annexure P-6: A copy of the Draft SPA issued by RECPDCL	276-292
9.	Annexure P-7: A copy of the Invoice dated 30.10.2023 issued by RECPDCL	293
10.	Annexure P-8: A copy of the email dated 27.10.2023 issued by RECPDCL to the Consortium along with the Survey Report	294-327
11.	Annexure P-9 (Colly.): Copies of the Amendments to the RFP dated 15.12.2023, 27.12.2023, 04.01.2024 and 15.01.2024	328-334
12.	Annexure P-10: A copy of the pre-bid meeting notice dated 06.11.2023	335
13.	Annexure P-11: A copy of the letter dated 11.12.2023 issued by RECPDCL	336
14.	Annexure P-12: A copy of RECPDCL's letter dated 18.12.2023	337-339
15.	Annexure P-13 (Colly.): Copies of the RFP clarifications dated 27.12.2023 and 15.01.2024	340-399
16.	Annexure P-14: A copy of the letter dated 01.01.2024 issued by RECPDCL to IGL2 along with finalised TSA.	400-532
17.	Annexure P-15: A copy of the email dated 09.02.2024 issued by RECPDCL	533-534
18.	Annexure P-16 (Colly.): A copy of the Certificate of Bid Evaluation dated 15.02.2024 along with CEA's letter dated 24.01.2024 constituting the Bid Evaluation Committee	535-538
19.	Annexure P-17: A copy of the Letter of Intent dated 15.02.2024	539-545
20.	Annexure P-18: A copy of the email dated 16.02.2024	546-554

S. No.	Particulars	Page Nos.
	issued by the Consortium to RECPDCL accepting LOI	
21.	Annexure P-19: A copy of RECPDCL's letter dated 05.04.2024 extending LOI timelines	555
22.	Annexure P-20: A copy of the email dated 19.02.2024 regarding due diligence of SPV	556-557
23.	Annexure P-21: A copy of MoP's letter dated 26.03.2024	558
24.	Annexure P-22: A copy of RECPDCL's email dated 27.03.2024 regarding final acquisition price	559-561
25.	Annexure P-23 (Colly.): A copy of the Contract Performance Guarantee dated 04.04.2024 and proof of payment of acquisition price	562-569
26.	Annexure P-24: A copy of the signed TSA dated 05.04.2024	570-703
27.	Annexure P-25: A copy of the signed Share Purchase Agreement dated 05.04.2024	704-724
28.	Vakalatnama and Board Resolution	725-726
29.	Filing Fee Form-1	727

Petitioner/Kallam Transco Ltd.

Date: 12.04.2024

Place: NOIDA, UP

**BEFORE THE HON'BLE CENTRAL ELECTRICITY REGULATORY
COMMISSION, NEW DELHI**

PETITION NO. ___/AT/2024

MEMO OF PARTIES

IN THE MATTER OF:

Kallam Transco Limited
Windsor, 1st Floor, Unit no. 101, Kalina,
Santacruz East, Mumbai, Maharashtra 400098

...Petitioner

VERSUS

1. REC Power Development and Consultancy Limited
D-Block, REC Headquarter, Plot No. I-4, Sector 29,
Gurgaon-122001

...RESPONDENT NO. 1

2. Central Transmission Utility of India Ltd.
CTU-Planning (1st Floor-A Wing), Saudamini,
Plot No. - 2, Sector- 29,
Near IFFCO Chowk Metro Station,
Gurgaon-122 001

...RESPONDENT NO. 2

APPLICANT/ Kallam Transco Limited

Place: Noida

Date:



BEFORE THE HON'BLE CENTRAL ELECTRICITY REGULATORY
COMMISSION,
NEW DELHI

PETITION NO. _____/AT/2024

IN THE MATTER OF:

Petition under Section 63 of Electricity Act, 2003 seeking adoption of Transmission Charges of the "Western Region Network Expansion Scheme in Kallam area of Maharashtra" being established by the Petitioner.

AND IN THE MATTER OF:

Kallam Transco Limited

...PETITIONER

Versus

REC Power Development and
Consultancy Ltd. and Anr.

...RESPONDENTS

**PETITION UNDER SECTION 63 OF THE ELECTRICITY ACT, 2003 SEEKING
ADOPTION OF TRANSMISSION CHARGES DISCOVERED THROUGH
TARIFF BASED COMPETITIVE BIDDING**

MOST RESPECTFULLY SHOWETH:

I. CONSPECTUS

1. The present Petition is being filed Kallam Transco Limited ("**Petitioner**"/"**Kallam Transco**") under Section 63 of the Electricity Act, 2003 ("**Act**") seeking adoption of transmission charges discovered through Tariff-Based Competitive Bidding process ("**TBCB**") conducted by



REC Power Development and Consultancy Limited. ("**Respondent No. 1**" / "**RECPDCL**") i.e., Bid Process Co-ordinator ("**BPC**"), to establish the Inter-State Transmission System for "*Western Region Network Expansion Scheme in Kallam area of Maharashtra*" ("**Project**"), on the basis of International competitive bidding in accordance with the "Tariff Based Competitive Bidding Guidelines for Transmission Service" ("**TBCB Guidelines**") and "Guidelines for Encouraging Competition in Development of Transmission Projects" issued by Ministry of Power, Government of India ("**MoP**") under Section 63 of the Act and as amended from time to time.

2. The need for implementation of the Project was discussed in the 14th Meeting of the National Commission on Transmission ("**NCT**") (as held on 09.06.2023), wherein construction of New Transmission Schemes was submitted by CTUIL for consideration of the 14th NCT which *inter-alia* included the present Project. The said scheme was approved by NCT to be implemented through TBCB process.
3. In view thereof, RECPDCL, being the BPC, issued the Request for Proposal dated 13.10.2023 ("**RfP**") for selection of a Transmission Service Provider ("**TSP**") for the establishment of the Project on a build, own, operate & transfer ("**BOOT**") basis. As per Clause 2 of the RfP read with its subsequent amendments from time to time, the Project comprises of the following elements:



"S.No.	Name of Transmission Element	Scheduled COD in months from Effective Date
1.	LILO of both circuits of Parli(M) – Karjat(M)/Lonikand-II (M) 400 kV D/c line (twin moose) at Kallam PS .	18 months
2.	4 Nos. 400 kV line bays at Kallam PS for LILO of both circuits of Parli(M) – Karjat(M)/Lonikand-II(M) 400 kV D/c line (twin moose) at Kallam PS • 400 kV line bays (AIS) – 4 Nos. (for Kallam PS end)	
3.	63 MVAR, 420 kV switchable line reactor (with NGR bypassing arrangement) on each ckt at Kallam PS end of Karjat – Kallam 400 kV D/c line (~140km) • 63 MVAR, 420 kV switchable line reactor including Switching equipment - 2 Nos. (at Kallam end	

Note:

a) TSP of Kallam PS (Kallam Transmission Ltd.) shall provide requisite space at Kallam PS for the above scope of work.

b) The 50 MVAR fixed line reactors on each ckt at Parli (M) end of Kallam – Parli (M) 400 kV D/c line shall be converted into switchable line reactors (with NGR bypass arrangement & provision of inter-tripping scheme to trip the line reactors along with the main line breakers) by MSETCL in matching time-frame of the above scheme. MSETCL vide email dated 08.06.2023 has informed that conversion of fixed 50 MVAR line reactor at 400 kV Parli (M) (Girwali) end into switchable reactor is feasible."

4. The Applicant was incorporated on 15.09.2023 by RECPDCL as its wholly owned subsidiary to initiate the activities for execution of the Project and subsequently to act as TSP after being acquired by the successful bidder selected through TBCB process. A copy of the Certificate of Incorporation of the Applicant company is annexed herewith and marked as



ANNEXURE P/1. A copy of the Memorandum of Association and Articles of Association of the Petitioner Company is annexed herewith and marked as **ANNEXURE P/2 (Colly).**

5. Notably, the a Consortium of IndiGrid 2 Ltd. ("**IGL2**") and IndiGrid 1 Ltd. ("**the Consortium**"), the current holding companies of the Petitioner participated in the aforesaid bidding process and subsequently, on 13.02.2024, the Consortium was declared as the successful bidder by RECPDCL, in pursuance to the e-reverse auction (held on 13.02.2024), with the lowest levelized transmission Charges of INR 152.50 million per annum, pursuant to the TBCB process conducted in terms of the RfP and the TBCB Guidelines issued by the MoP under Section 63 of the Act. Accordingly, a letter of intent dated 15.02.2024 ("**LoI**") was issued by RECPDCL to the Consortium.
6. It is relevant to note the Clause 2.15.4 of the RfP mandates the TSP to apply to this Hon'ble Commission for adoption of Transmission Charges, as required under Section 63 of the Act within five (5) working days of acquiring of the Petitioner (previously a wholly owned subsidiary of RECPDCL before its acquisition by the Consortium), which was incorporated as a Special Purpose Vehicle ("**SPV**") for implementation of the Project.
7. In view thereof, the present Petition is being preferred by the Petitioner seeking adoption of the transmission charges of INR 152.50 million per



annum by this Hon'ble Commission pursuant to the TBCB process conducted by the BPC.

II. DESCRIPTION OF THE PARTIES

8. The Petitioner i.e., Kallam Transco Limited was a wholly owned subsidiary of RECPDCL and was incorporated as an SPV for implementation of the Project. The Petitioner was acquired by the Consortium after being declared as a successful (i.e., L1) bidder in the bidding process conducted by RECPDCL for selection of a TSP for establishment of the Project.
- 8.1. Respondent No. 1 i.e., RECPDCL is a wholly owned subsidiary of REC Ltd., and is a company incorporated under the Companies Act, 1956. On 13.04.2023, MoP notified RECPDCL as the BPC for the purpose of selection of Bidder as TSP to establish Inter-State Transmission System for construction of the Project through tariff based competitive bidding process.
- 8.2. Respondent No. 2 i.e., Central Transmission Utility of India Limited ("**CTUIL**") is notified to undertake the functions of Central Transmission Utility as provided under Section 38 of the Act and discharging, *inter-alia*, functions of planning and co-ordination pertaining to ISTS with all the concerned authorities.

III. JURISDICTION

9. This Hon'ble Commission has the jurisdiction to adjudicate upon the present Petition as the present Project which is to be constructed by the Petitioner is a part of the Inter-State transmission system. It is thus



submitted that this Hon'ble Commission has the power to adjudicate upon the present Petition under Section 63 read with Section 79(1)(c) of the Act.

Following are the relevant of Section 63 and 79(1)(c) of the Act:

“Section 63. (Determination of tariff by bidding process):

Notwithstanding anything contained in section 62, the Appropriate Commission shall adopt the tariff if such tariff has been determined through transparent process of bidding in accordance with the guidelines issued by the Central Government.

...

Section 79. (Functions of Central Commission): --- (1) *The Commission shall discharge the following functions, namely:-*

...(c) to regulate the inter-State transmission of electricity ;”

- 9.1. In terms thereof, this Hon'ble Commission has the power to adjudicate upon the present Petition and adopt the transmission charges as provided in the present Petition discovered through transparent process of bidding in accordance with TBCB Guidelines

IV. FACTS AND ISSUES FOR CONSIDERATION

10. The relevant facts and issues for the kind consideration of this Hon'ble Commission are as follows:

- 10.1. On 19.06.2023, the 14th Meeting of the NCT was held, wherein construction of New Transmission Schemes was submitted by CTUIL for consideration of the NCT, and the said Schemes *inter-alia* included the present Project. In the said meeting, NCT approved the implementation of



the Project through TBCB procees. A copy of the Minutes of Meeting of 14th NCT is annexed hereto and marked as **ANNEXURE P/3**.

10.2. On 19.07.2024, MoP *vide* its Gazette Notification No. CG-DL-E-11082023-248014 notified RECPDCL to be the BPC for the purpose of selection of Bidder as a TSP to establish an Inter-State transmission system for construction of the Project in accordance with the TBCB Guidelines dated 10.08.2021, issued by MoP under Section 63 of the Act (Refer Sr. No. 1 of the Gazette Notification). A copy of the Gazette Notification dated 19.07.2024 issued by MoP, Gol is annexed hereto and marked as **ANNEXURE P/4**.

10.3. On 13.10.2023, RECPDCL issued the RfP and Global Invitation for selection of Bidder as a TSP through TBCB process in order to establish Inter-State Transmission scheme for Western Region Network Expansion in Kallam area of Maharashtra. One of the main objectives of the bidding process was to select a successful bidder pursuant to the RfP, who shall acquire one hundred percent (100%) of the equity shares of the Petitioner for construction of the Project. A copy of the RfP dated 13.10.2023 is annexed herewith and marked as **ANNEXURE P/5**.

10.4. RECPDCL, in addition to the RfP, issued the Draft Share Purchase Agreement ("**SPA**"), which is a tripartite agreement between the Petitioner, RECPDCL, and the Successful Bidder. A copy of the Draft SPA issued by RECPDCL along with the RfP is annexed herewith and marked as **ANNEXURE P/6**.



- 10.5. On 15.09.2023, the Petitioner was incorporated under the provisions of the Companies Act, 2013 by RECPDCL as its 100% wholly owned subsidiary to initiate the activities for undertaking pre-bid obligations in relation to the execution of the Project and subsequently to act as the TSP.
- 10.6. As per the requirements stated in the RfP issued by RECPDCL, the Petitioner paid an amount to the tune of Rs. 5,90,000.00 (Rupees Five Lakh Ninety Thousand only) (inclusive of 18% GST) to RECPDCL, as the said amount was mandatory to be paid in order to request for the issuance of the RfP and other relevant documents. RECPDCL issued its Invoice dated 30.10.2023 regarding payment of aforesaid fees. A copy of the Invoice dated 30.10.2023 issued by RECPDCL is annexed herewith and marked as **ANNEXURE P/7**.
- 10.7. On 27.10.2023, RECPDCL sent an email to the Consortium, wherein as per the requirement of Clause 1.6.2.1 (1) of the RfP, RECPDCL prepared and attached a Survey Report of the Project for the bidders participating in the Bid process. A copy of the email dated 27.10.2023 issued by RECPDCL to the Consortium along with the Survey Report is annexed herewith and marked as **ANNEXURE P/8**.
- 10.8. It is relevant to note that RECPDCL issued certain amendments to the RfP *inter alia*, extending the date of bid submission for the Project. As per the amendment dated 04.01.2024 the final due date for submission of online RfP bids through the electronic bidding platform for the Project was 19.01.2024. Also, the RfP (Technical) Bids were supposed to be opened



on 19.01.2024. Copies of the Amendments to the RFP dated 15.12.2023, 27.12.2023, 04.01.2024 and 15.01.2024 are annexed herewith and marked as **ANNEXURE P/9 (Colly.)**.

10.9. On 06.11.2023, RECPDCL informed the Consortium that a pre-bid meeting through video conferencing was scheduled on 08.11.2023. A copy of the pre-bid meeting notice dated 06.11.2023 is annexed hereto and marked as **Annexure P/10**.

10.10. RECPDCL *vide* its letter dated 11.12.2023 to IGL2 informed the estimated Acquisition Price payable by the bidder to RECPDCL for acquisition of one hundred percent (100%) of the equity shareholding of the Petitioner is Rs. 640.66 Lakh (Rupees Six Crore Forty Lakh Sixty Six Thousand Only). A copy of the letter dated 11.12.2023 issued by RECPDCL to is annexed herewith and marked as **ANNEXURE P/11**.

10.11. On 18.12.2023, RECPDCL wrote a letter to the Consortium providing a copy of the drawing of the existing Kallam Substation. A copy of RECPDCL's letter dated 18.12.2023 is annexed hereto and marked as **Annexure P/12**.

10.12. On 27.12.2023 and 15.01.2024, RECPDCL issued clarifications (through email) to the RfP documents, (as raised by the bidders). Copies of the clarifications dated 27.12.2023 and 15.01.2024 issued by RECPDCL to the bidders are annexed herewith and marked as **ANNEXURE P/13(Colly.)**.



10.13. On 01.01.2024, RECPDCL *vide* its letter to IGL2 issued the copy of the finalised Transmission Service Agreement (“**TSA**”) (which is an agreement between the CTUIL and the Petitioner) in terms of Clause 1.6.2.1 (6) of the RfP. A copy of the letter dated 01.01.2024 issued by RECPDCL to IGL2 along with finalised TSA is annexed herewith and marked as **ANNEXURE P/14**.

10.14. On 09.02.2024, RECPDCL issued an email to the Consortium declaring that the Consortium was a Qualified Bidder in terms of Clause 3.2 and 3.4 of the RfP. A copy of the email dated 09.02.2024 issued by RECPDCL is annexed herewith and marked as **ANNEXURE P/15**.

10.15. On 13.02.2024, the e-Reverse Auction was held by RECPDCL.

10.16. Subsequently, the Bid Evaluation Committee (“**BEC**”) held its meeting for evaluation of the bids placed by the bidders wherein the Consortium was declared as the successful bidder at the quoted Transmission tariff of Rs152.50 million per annum. A copy of the Certificate of Bid Evaluation dated 15.02.2024 along with CEA’s letter dated 24.01.2024 constituting the Bid Evaluation Committee are annexed herewith and marked as **ANNEXURE P/16 (Colly.)**.

Accordingly, on 15.02.2024, RECPDCL issued the Lol to the Consortium.

A copy of the Letter of Intent dated 15.02.2024 issued by RECPDCL to the Consortium is annexed herewith and marked as **ANNEXURE P/17**.

10.17. In terms of the Lol, the Consortium was required to unconditionally accept the terms of the Lol within seven (7) days of the issuance of the Lol.



Accordingly, the Consortium *vide* its email dated 16.02.2024 to RECPDCL, issued the unconditional acceptance copy of the Lol. A copy of the email dated 16.02.2024 issued by the Consortium to RECPDCL is annexed herewith and marked as **ANNEXURE P/18**.

10.18. It is pertinent to note that Clauses 2.15.2, 2.15.3 and 2.15.4 of the RfP provide for a timelines after issuance of the Lol, which requires the successful bidder to *inter alia* acquire the SPV i.e., the Petitioner within 10 days from issuance of Lol and further mandates the Petitioner to file petitions before this Hon'ble Commission seeking adoption of tariff and grant of transmission licence, within 5 days of the acquisition of the SPV by the successful bidder i.e., the Consortium. Further, as per Clause 2.15.2 of the RfP and the Lol, the Successful Bidder is also required to *inter-alia* provide the Contract Performance Guarantee ("CPG") to the Nodal Agency, within 10 days of issuance of Lol and execute the SPA and the TSA before acquiring the Petitioner/SPV. On 05.04.2024, RECPDCL issued a letter to the Consortium extending the time for completing the activities mentioned in Clauses 2.15.2, 2.15.3 and 2.15.4 of the RfP till 15.04.2024. A copy of letter dated 05.04.2024 is annexed hereto and marked as **Annexure P/19**.

10.19. On 16.02.2024 RECPDCL invited the Consortium to conduct the process of due diligence on 20.02.2024. The said Due Diligence was completed by the Consortium on 19.02.2024. A copy of the email dated 16.02.2024 is annexed hereto and marked as **Annexure P/20**.

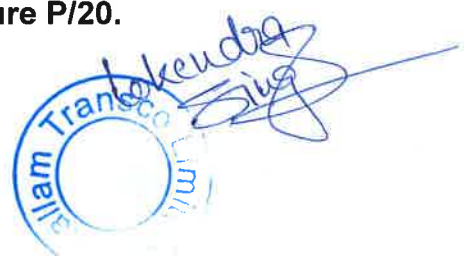

A handwritten signature in blue ink is written over a circular blue stamp. The stamp contains the text "Allam Transco Limited" around its perimeter. The signature appears to be "Lakendra Singh".

10.20. On 26.03.2024, MoP, Government of India issued its approval for sale and transfer of Kallam Transco Ltd.'s shares to the Consortium. A copy of the letter dated 26.03.2024 is annexed herewith and marked as **Annexure P/21.**

10.21. On 27.03.2024, RECPDCL wrote to the Consortium providing the details of the Final Acquisition Price to be paid for acquisition of the Petitioner. RECPDCL further stated that for CPG and execution of the TSA, the Consortium may kindly coordinate with CTUIL (Respondent No. 2). A copy of RECPDCL's email dated 27.03.2024 is annexed hereto and marked as **Annexure P/22.**

10.22. In view thereof, the Consortium on furnished a CPG dated 04.04.2024, for an amount to the tune of Rs. 3 Crores (Rupees Three Crores only) (as per Clause 2.12.1 of the RfP), with an expiry date being 31.01.2026 (claim expiry date 31.01.2027), in favour of CTUIL.

10.23. Thereafter, the Consortium acquired the Petitioner/SPV after executing the Share Purchase Agreement on 05.04.2024, on payment of the Acquisition Price to the tune of Rs. 6,46,63,522 (Rs. Six Crore Forty Six Lakhs Sixty Three Thousand Five Hundred Twenty Two Only) on 05.04.2024, along with the execution of the Transmission Service Agreement with CTUIL on 05.04.2024.

A copy of the Contract Performance Guarantee dated 04.04.2024 and proof of payment of acquisition price is annexed herewith and marked as **ANNEXURE P/23 (Colly.)** A copy of the signed TSA is annexed herewith



as **ANNEXURE P/24** and a copy of the signed Share Purchase Agreement is annexed herewith as **ANNEXURE P/25**. It is humbly submitted that in terms of Clause 2.15.4 of the RfP, the present Petition is being filed by the Petitioner within 5 working days from the acquisition of the Petitioner/SPV by the Consortium.

- 10.24. Further, after complying with all the obligations pertaining to the acquisition of the Petitioner by the Consortium, the Petitioner has also preferred an application/Petition for grant of Transmission Licence with respect to the Project under Section 14 read with Section 15(1) of the Act before this Hon'ble Commission separately, *inter alia* in accordance with the provisions of Clause 2.15.4 of the RfP.
11. It is submitted that the present Petition is being filed under Section 63 of the Act seeking adoption of the Transmission Charges of Rs. 152.50 million per annum which has been determined through transparent competitive bidding process conducted in accordance with the guidelines issued by the MoP.
12. It is further submitted that the Project is governed by the TSA signed between the Petitioner and CTUIL and all the terms of which shall be binding on the signatories to the TSA. Further, the Petitioner would implement the Project as per the terms and conditions provided in the TSA and the time over run and cost overrun, if applicable, shall be claimed by the Petitioner in accordance with the applicable provisions of the TSA read with the provisions of the Act, the bidding documents, the regulations of



Lokendra Singh

this Hon'ble Commission and the exercise of power by this Hon'ble Commission under the Act and the Regulations.

13. It is, therefore, submitted that in accordance with Section 63 of the Act and in the terms of the RfP documents, this Hon'ble Commission may be pleased to adopt the aforementioned Transmission Charges as quoted by the Consortium, with respect to the subject Transmission System.
14. The present petition is filed *bona fide* and in the interest of justice.

PRAYER

15. The Petitioner hereby humbly prays the Hon'ble Commission to:
 - (a) Adopt the Transmission Charges of Rs. 152.50 million per annum discovered through a transparent competitive bidding process pursuant to the RFP dated 13.10.2023, for "*Western Region Network Expansion in Kallam area of Maharashtra*", comprising of the elements/ assets as detailed in the executed TSA;
 - (b) Allow the "*Western Region Network Expansion in Kallam area of Maharashtra*", to be a part of the Inter-State Transmission Charges and direct that the recovery of transmission charges shall be in accordance with the terms of the Transmission Service Agreement executed between the parties and the CERC (Sharing of Inter-State Transmission Charges and losses) Regulations 2020 and its amendments;



- (c) Condone any inadvertent errors omissions/errors/shortcomings and permit the Petitioner to add/change/modify/alter these filings and make further submissions as may be required at a future date;
AND/OR
- (d) Pass any such other order/orders, as may be deemed fit and proper in the facts and circumstances of the case.

Petitioner/Kallam Transco Ltd.

Date: 10.04.2024

Place: NOIDA, UP





**BEFORE THE CENTRAL ELECTRICITY REGULATORY
COMMISSION, AT NEW DELHI
PETITION NO. ____ /AT/2024
IN THE MATTER OF:**

Kallam Transco Ltd.

...Petitioner

Versus

REC Power Development and
Consultancy Ltd. & Anr.

...Respondents

AFFIDAVIT

I, Lokendra Singh Ranawat, Son of Shri B.S. Ranawat, aged about 40 years, being the authorized representative of Kallam Transco Ltd., Petitioner herein, having my office at Windsor, 1st Floor, Unit no. 101, Kalina, Santacruz East, Mumbai, Maharashtra 400098, presently at Noida, U.P., do hereby solemnly affirm and state as under:

1. That I am the authorized signatory of the Petitioner and as such I am fully conversant with the facts and circumstances of the present case and therefore authorised and competent on behalf of the Petitioner to swear and affirm this affidavit.
2. I state that I have read and understood the contents of the accompanying Petition and the same has been drafted under my instructions and after carefully going through the same, I state that the same are true and correct to the best of my knowledge or belief and it is stated that no part of it is false and nothing material has been concealed there from.
3. I state that the annexures annexed to the accompanying Petition, if any, are true copies of their respective originals.

Lokendra Singh
DEPONENT

VERIFICATION

I, the deponent above named do hereby verify that the contents of the above affidavit are true and correct to the best of my knowledge and belief and nothing material has been concealed there from.

Verified at Noida, Uttar Pradesh on 10th day of April, 2024.

Lokendra Singh
DEPONENT

ATTESTED
[Signature]
NOTARY PUBLIC
GOVT. OF INDIA



10 APR 2024



**GOVERNMENT OF INDIA
MINISTRY OF CORPORATE AFFAIRS**

Central Registration Centre

Certificate of Incorporation

[Pursuant to sub-section (2) of section 7 and sub-section (1) of section 8 of the Companies Act, 2013 (18 of 2013) and rule 18 of the Companies (Incorporation) Rules, 2014]

I hereby certify that KALLAM TRANSCO LIMITED is incorporated on this FIFTEENTH day of SEPTEMBER TWO THOUSAND TWENTY THREE under the Companies Act, 2013 (18 of 2013) and that the company is Company limited by shares

The Corporate Identity Number of the company is **U42202DL2023GOI420108**

The Permanent Account Number (PAN) of the company is **AAKCK5142N***

The Tax Deduction and Collection Account Number (TAN) of the company is **DELK26819C***

Given under my hand at Manesar this FIFTEENTH day of SEPTEMBER TWO THOUSAND TWENTY THREE

SHEETAL KUMARI

Assistant Registrar of Companies/ Deputy Registrar of Companies/ Registrar of Companies

For and on behalf of the Jurisdictional Registrar of Companies

Registrar of Companies

Central Registration Centre

Disclaimer: This certificate only evidences incorporation of the company on the basis of documents and declarations of the applicant(s). This certificate is neither a license nor permission to conduct business or solicit deposits or funds from public. Permission of sector regulator is necessary wherever required. Registration status and other details of the company can be verified on mca.gov.in

Mailing Address as per record available in Registrar of Companies office:

KALLAM TRANSCO LIMITED

CORE-4, SCOPE COMPLEX,7, LODHI ROAD,Lodi Road,Delhi,Central Delhi-110003,Delhi

*as issued by Income tax Department



19 ANNEXURE P/2 (COLLY.)

Form No. INC-33



Form language

English Hindi

e-MOA (e-Memorandum of Association)

[Pursuant to Schedule I (see Sections 4 and 5) to the Companies Act, 2013]

Refer instruction kit for filing the form

All fields marked in * are mandatory

*** Table applicable to company as notified under schedule I of the Companies Act, 2013**

(A - MEMORANDUM OF ASSOCIATION OF A COMPANY LIMITED BY SHARES
B - MEMORANDUM OF ASSOCIATION OF A COMPANY LIMITED BY GUARANTEE AND NOT HAVING A SHARE CAPITAL
C - MEMORANDUM OF ASSOCIATION OF A COMPANY LIMITED BY GUARANTEE AND HAVING A SHARE CAPITAL
D - MEMORANDUM OF ASSOCIATION OF AN UNLIMITED COMPANY AND NOT HAVING SHARE CAPITAL
E - MEMORANDUM OF ASSOCIATION OF AN UNLIMITED COMPANY AND HAVING SHARE CAPITAL)

A - MEMORANDUM OF ASSOCIATION OF A COMPANY LIMITED BY SHARES

Table A/B/C/D/E

1 The name of the company is

KALLAM TRANSCO LIMITED

2 The registered office of the company will be situated in the State of

Delhi

3 (a) The objects to be pursued by the company on its incorporation are:

1. To plan, promote and develop an integrated and efficient power transmission system network in all its aspects including planning, investigation, research, design and engineering, preparation of preliminary, feasibility and definite project reports, construction, operation and maintenance of transmission lines, sub-stations, load dispatch stations and communication facilities and appurtenant works, coordination of integrated operation of regional and national grid system, execution of turn-key jobs for other utilities/organizations and wheeling of power in accordance with the policies, guidelines and objectives laid down by the Central Government from time to time.
2. To study, investigate, collect information and data, review operation, plan, research, design and prepare Report, diagnose operational difficulties and weaknesses and advise on the remedial measures to improve, undertake development of new

and innovative product connected with business of the Company as well as modernize existing EHV, HV lines and Sub-Stations.

3.To act as consultants, technical advisors, surveyors and providers of technical and other services to Public or Private Sector enterprises engaged in the planning, investigation, research, design and preparations of preliminary, feasibility and definite project reports, manufacture of power plant and equipment, construction, generation, operation and maintenance of power transmission system from power generating stations and projects, transmission and distribution of power.

4.To plan, promote, develop, erect and maintain, operate and otherwise deal in Telecommunication networks and services in all its aspects including planning, investigation, research, design and engineering, preparation of preliminary, feasibility and definite project reports: to purchase, sell, import, export, assemble, manufacture, install, commission, maintain, operate commercially whether on own or along with other, on lease or otherwise. These networks and for such purposes to set up and/ or install all requisite communications facilities and other facilities including fibre optic links, digital microwave links, communication cables, other telecommunication means, telephone and other exchanges, co-axial stations, microwave stations, repeater stations, security system databases, billing systems, subscriber management systems and other communication systems whether consisting of sound, visual impulse, or otherwise, existing or that may be developed or invented in the future and to manufacture, purchase, sell, import, export, assemble, take or give on lease/rental/subscription basis or by similar means or

otherwise deal in all components and other support and ancillary hardware and software systems, accessories, parts and equipments etc. used in or in connection with the operation of the above communication systems and networks including to deal with telecommunication operations or directly with the general public, commercial companies or otherwise.

(b) *Matters which are necessary for furtherance of the objects specified in clause 3(a) are

- 1.To obtain license, approvals and authorization from Governmental Statutory and Regulatory Authorities, as may be necessary to carry out and achieve the Objects of the Company and connected matters which may seem expedient to develop the business interests of the Company in India and abroad.
- 2.To enter into any arrangement with the Government of India or with any State Government or with other authorities/ commissions, local bodies or public sector or private sector undertakings, Power Utilities, Financial Institutions, Banks, International Funding Agencies and obtain such charters, subsidies, loans, advances or other money, grants, contracts, rights, sanctions, privileges, licenses or concessions whatsoever (whether statutory or otherwise) which the Company may think it desirable to obtain for carrying its activities in furthering the interests of the Company or its members.
- 3.To enter into any agreement, contract or any arrangement for the implementation of the power generation, evacuation, transmission and distribution system and network with Power/ Transmission Utilities, State Electricity Boards, Vidhyut Boards, Transmission Companies, Generation Companies, Licensees, Statutory bodies, other organizations (whether in

Private, Public or Joint Sector Undertaking) and bulk consumers of power etc.

4.To secure the payments of money, receivables on transmission and distribution of electricity and sale of fuel, as the case may be, to the State Electricity Boards, Vidyut Boards, Transmission Utilities, Generating Companies, Transmission Companies, Distribution Companies, State Governments, Licensees, statutory bodies, other organizations (whether in Private, Public or Joint Sector Undertaking) and bulk consumers of power etc. through Letter of Credits/ESCROW and other security documents.

5.To coordinate with the Central Transmission Utility of electricity generated by it under the relevant provisions of Electricity Act 2003 and any amendments thereto.

6.Subject to provisions of Sections 73, 74, 179, 180 & 186 and other applicable provisions of the Companies Act, 2013 and rules made thereunder and subject to other laws or directives, if any, of SEBI/RBI, to borrow money in Indian rupees or foreign currencies and obtain foreign lines of credits/ grants/ aids etc. or to receive money or deposits from public for the purpose of the Company's business in such manner and on such terms and with such rights, privileges and obligations as the Company may think fit. The Company may issue bonds/ debentures whether secured or unsecured; bills of exchange, promissory notes or other securities, mortgage or charge on all or any of the immovable and movable properties, present or future and all or any of the uncalled capital for the time being of the Company as the Company may deem fit and To repay, redeem or pay off any such securities or charges.

7.To lend money on property or on mortgage of immovable properties or against Bank guarantee and to make advances

of money against future supply of goods and services on such terms as the Directors may consider necessary and to invest money of the Company in such manner as the Directors may think fit and to sell, transfer or to deal with the same.

8.To own, possess, acquire by purchase, lease or otherwise rights, title and interests in and to, exchange or hire real estate, equipment, Transmission lines, lands, buildings, apartments, plants, equipment, machinery, fuel blocks and hereditaments of any tenure or descriptions situated in India or abroad or any estate or interest therein and any right over or connected with land so situated and turn the same to account in any manner as may seem necessary or convenient for the purpose of business of the Company and to hold, improve, exploit, reorganize, manage, lease, sell, exchange or otherwise dispose of the whole or any part thereof.

9.Subject to applicable provisions of Companies Act, 2013, to subscribe for, underwrite, or otherwise acquire, hold, dispose of and deal with the shares, stocks, debentures or other securities and titles of indebtedness or the right to participate in profits or other similar documents issued by any Government authority, Corporation or body or by any company or body of persons and any option or right in respect thereof.

10.To create any depreciation fund, reserve fund, sinking fund, insurance fund, gratuity, provident fund or any other fund, for depreciation or for repairing, improving extending or maintaining any of the properties of the Company or for any other purposes whatsoever conducive to the interests of the Company.

11.To acquire shares, stocks, debentures or securities of any company carrying on any business which this Company is

entitled to carry on or acquisition of undertaking itself which may seem likely or calculated to promote or advance the interests of the Company and to sell or dispose of or transfer any such shares, stocks or securities and the acquired undertaking.

12.To enter into partnership or into any agreement for joint working, sharing or pooling profits, joint venture, amalgamation, union of interests, co-operation, reciprocal concessions or otherwise or amalgamate with any person or company carrying on or engaged in or about to carry on or engaged in any business or transaction in India or abroad which the Company is authorized to carry on or engage in any business undertaking having objects identical or similar to, as are being carried on by this Company.

13.To establish and maintain agencies, branch offices and local agencies, to procure business in any part of India and world and to take such steps as may be necessary to give the Company such rights and privileges in any part of the world as deemed proper in the interest of the Company.

14.To promote and undertake the formation of any institution or Company or subsidiary company or for any aforesaid objects intended to benefit the Company directly or indirectly and to coordinate, control and guide their activities.

15(a).To negotiate and enter into agreements and contracts with domestic and foreign companies, persons or other organizations, banks and financial institutions, in relation to the business of the Company including that of technical know-how, import, export, purchase or sale of plant, machinery, equipment, tools, accessories and consumables, financial assistance and for carrying out all or any of the objects of the Company.

15(b). To negotiate and enter

into

agreements and contracts for execution of turnkey jobs, works, supplies and export of plant, machinery, tools and accessories etc.

16. Upon and for the purpose of any issue of shares, debentures or any other securities of the Company, to enter into agreement with intermediaries including brokers, managers of issue/commission agents and underwriters and to provide for the remuneration of such persons for their services by way of payment in cash or issue of shares, debentures or other securities of the Company or by granting options to take the same or in any other manner as permissible under the law.

17. To enter into contracts of indemnity and get guarantee and allocations for the business of the Company.

18. To make arrangements for training of all categories of employees and to employ or otherwise engage experts, advisors, consultants etc. in the interest of achieving the Company's objects.

19. To promote conservation and protection of electricity from theft, safety of life and to protect environments including air, land and water etc.

20. To pay and provide for the remuneration, amelioration and welfare of persons employed or formerly employed by the Company and their families providing for pension, allowances, bonuses, other payments or by creating for the purpose from time to time the Provident Fund, Gratuity and other Funds or Trusts. Further to undertake building or contributing to the building or houses, dwellings or chawls by grants of money, or by helping persons employed by the Company to effect or maintain insurance on their lives by contributing to the payment of premium or otherwise and by providing or subscribing or contributing towards

educational institutions, recreation, hospitals and dispensaries, medical and other assistance as the Company may deem fit.

21.To ensure any rights, properties, undertakings, contracts, guarantees or obligations or profits of the Company of every nature and kind in any manner with any person, firm, association, institution or company.

22.To distribute among members of the Company dividend including bonus shares out of profits, accumulated profits or funds and resources of the Company in any manner permissible under law.

23.To institute, conduct, defend, compound or abandon any legal proceedings by or against the Company or its officers or otherwise concerning the affairs of the Company and also to compound and to allow time for payment or satisfaction of any debts or recovery due, claims or demands by or against the Company and to refer any claims or demands by or against the Company or any differences arising in execution of contracts to conciliation and arbitration and to observe, comply with and/or challenge any awards preliminary, interim or final made in any such arbitration.

24.To pay out of the funds of the Company all costs, charges, expenses and preliminary and incidental to the promotion, formation, establishment and registration of the Company or other expenses incurred in this regard.

25.Subject to provisions of Sections 181, 182 & 183 of Companies Act, 2013 to contribute money or otherwise assist to charitable, benevolent, religious, scientific national, defense, public or other institutions or objects or purposes.

26.To open an account or accounts with any individual, firm or company or with any

bank bankers or shroofs and to pay into and withdraw money from such account or accounts.

27.To accept gifts, bequests, devises and donations from members and others and to make gifts to members and others of money, assets and properties of any kind.

28.To carry out all or any of the objects of the company and do all or any of the above things in any part of the world and either as principal, agent, contractor or trustee or otherwise and either alone or in conjunction with others.

29.To negotiate and/or enter into agreement and contract with individuals, companies, corporations, foreign or Indian, for obtaining or providing technical, financial or any other assistance for carrying on all or any of the objects of the Company and also for the purpose of activating, research, development of projects on the basis of know-how and/or financial participation and for technical collaboration, and to acquire or provide necessary formulate and patent rights for furthering the objects of the company.

30.To aid peculiarly or otherwise, any association, body or movement having for its object the solution, settlement or surmounting of industrial or labour problems or trouble or the promotion of industry or trade.

31.Subject to the provisions of Companies Act, 2013 or any amendment or re-enactment thereof in the event of winding up to distribute among the members in specie any property of the Company or any proceeds of sale on disposal of any property in accordance with the provisions of the Act.

32.To do all such other things as may be deemed incidental or conducive to the attainment of the above Objects or any of them and to carry on any business which may seem to the Company capable of being conveniently

carried in connection with any of the Company's Objects or calculated directly or indirectly to enhance the value of or render profitable any of the Company's property or rights.

33.To establish, provide, maintain and conduct or otherwise subsidies research laboratories and experimental workshops for scientific, technical or researches, experiments and to undertake and carry on directly or in collaboration with other agencies scientific and technical research experiments and tests of all kinds and to process, improve and invent new products and their techniques of manufacture and to promote, encourage, reward in every manner studies and research, scientific and technical investigations and inventions of any kind that may be considered likely to assist, encourage and promote rapid advances in technology, economies, import substitution or any business which the Company is authorized to carry on.

34.Subject to provisions of the Companies Act, 2013, to evolve scheme for restructuring or arrangement, to amalgamate or merge or to enter into partnership or into any consortium or arrangement for sharing of profits, union of interests, co-operation, joint venture with any Person or Persons, partnership firm/firms, or company or companies carrying on or engaged in any operation capable of being conducted so conveniently in cooperation with the business of the Company or to benefit the Company or to the activities for which the Company has been established.

35.To apply for purchase, or otherwise acquire any trade marks, patents, brevets, inventions, licenses, concessions and the like, conferring any exclusive or nonexclusive or limited rights to use, or any

secret or other information as to any invention which may be capable of being used for any of the purposes of the Company, or the acquisition of which may benefit the Company and to use, exercise, develop or grant licenses in respect of or otherwise turn to account the property, rights or information so acquired.

36. To sell, dispose or hive off an undertaking of the Company or any part thereof for such consideration as the Company may think fit and in particular for shares, debentures or securities of any other association, corporation or company.

37. To sell, improve, manage, develop, exchange, loan, lease or let, under-lease, sub - let, mortgage, dispose of, deal with in any manner, turn to account or otherwise deal with any rights or property of the Company.

4 The liability of the member(s) is limited, and this liability is limited to the amount unpaid if any, on the shares held by them.

The liability of the member(s) is limited

The liability of the member(s) is Unlimited

5 Every member of the company undertakes to contribute:

(i) to the assets of the company in the event of its being wound up while he is a member, or within one year after he ceases to be a member, for payment of the debts and liabilities of the company or of such debts and liabilities as may have been contracted before he ceases to be a member; and

(ii) to the costs, charges and expenses of winding up (and for the adjustment of the rights of the contributories among

themselves), such amount as may be required, not exceeding * rupees.

(iii) The share capital of the company is rupees, divided into

Equity Share	Shares of	10	Rupees each		50000
--------------	-----------	----	-------------	--	-------

6

We, the several persons, whose names and address are subscribed, are desirous of being formed into a company in pursuance of this memorandum of association, and we respectively agree to take the number of shares in the capital of the company set against our respective names:

I, whose name and address is given below, am desirous of forming a company in pursuance of this memorandum of association and agree to take all the shares in the capital of the company:

We, the several persons, whose names and addresses are subscribed, are desirous of being formed into a company in pursuance of this memorandum of association:

Subscriber Details					
S. No.	*Name, Address, Description and Occupation	DIN / PAN / Passport number	No. of shares taken	DSC	Dated
1	ALOK SINGH S/O JAGDHARI SINGH NOMINEE OF REC POWER DEVELOPMENT AND CONSULTANCY LIMITED R/O MF-23, ELDECO MANSIONZ, SECTOR-48, SOHNA ROAD, GURUGRAM - 122018, OCCUPATION-SERVICE	07498786	1 Equity,0 Preference		05/09/2023
2	REC POWER DEVELOPMENT AND CONSULTANCY LIMITED, CORE-4, SCOPE COMPLEX, 7, LODHI ROAD, NEW DELHI-110003, THROUGH ITS CEO RAJESH KUMAR S/O SHRINIWAS GUPTA R/O L-187, NAG MANDIR KE PAS SHASTRI NAGAR, ASHOK VIHAR, DELHI-110052, OCCUPATION-SERVICES	06941428	49994 Equity,0 Preferenc		05/09/2023
3	MOHAN LAL KUMAWAT S/O SHRI RAMU RAM KUMAWAT NOMINEE OF REC POWER DEVELOPMENT AND CONSULTANCY LIMITED FLAT NO 142 TOWER -1 GC EMERALD, RAMPRASTHA GREENS VAISHALI SECTOR-7, GHAZIABAD-201010, UTTAR PRADESH, OCCUPATION-SERVICE	07682898	1 Equity,0 Preference		05/09/2023
4	PUTHIYARKATTU SHIVARAMAN HARIHARAN S/O SHRI PUTHIYARAKAT VELAYUDHAN SIVARAMAN NOMINEE OF REC POWER DEVELOPMENT AND CONSULTANCY LIMITED FLAT NO.104, SADAR APARTMENT, MAYUR VIHAR EXTENTION, PHASE-1, PLOT NO.9, NEW DELHI-110091, OCCUPATION-SERVICE	08657652	1 Equity,0 Preference		05/09/2023
	ARVIND KUMAR S/O NAND KISHOR SINGH				05/09/2023

5	NOMINEE OF REC POWER DEVELOPMENT AND CONSULTANCY LIMITED R/O T4-8A, SAI VATIKA APARTMENT, SECTOR-63, FARIDABAD - 121004, OCCUPATION-SERVICE	AHHPK0531C	1 Equity,0 Preference	
6	THANGARAJAN BOSH S/O SHRI SITHAN THANGARAJAN NOMINEE OF REC POWER DEVELOPMENT AND CONSULTANCY LIMITED R/O APARTMENT NO S-2, MIDDLE PORTION 2-B, JANGPURA, MATHURA ROAD, NEW DELHI-110014, OCCUPATION-SERVICE	02772316	1 Equity,0 Preference	05/09/2023
7	SAHAB NARAIN S/O HARI NARAIN NOMINEE OF REC POWER DEVELOPMENT AND CONSULTANCY LIMITED R/O A-1, FLAT NO 103, SOAMI NAGAR, MALVIYA NAGAR, DELHI-110017, OCCUPATION-SERVICE	03641879	1 Equity,0 Preference	05/09/2023
Total shares taken			50000 Equity,0 Preference	

Signed before me

Membership type of the witness (ACA/FCA/ACS/FCS/ACMA/FCMA)	*Name of the witness	*Address, Description and Occupation	DIN / PAN / Passport number / Membership number	DSC	Dated
FCA	VINAY KUMAR	1803, TOWER-9, LA RESIDENTIA, TECH ZONE-4, GREATER NOIDA WEST-201306	402996		05/09/2023

7 Shri / Smt

Of

resident of

aged

years shall be the nominee in the event of death of the sole member.

Form No. INC-34**e-AOA (e-Articles of Association)**

[Pursuant to Section 5 of the Companies Act, 2013 and rules made thereunder read with Schedule I]



Form language

 English Hindi

Refer instruction kit for filing the form.

All fields marked in * are mandatory

Table applicable to company as notified under schedule I of the Companies Act, 2013
(F, G, H)

F

Table F / G / H (basis on the selection of above-mentioned field) as notified under schedule I of the companies Act, 2013 is applicable to

(F – a company limited by shares

G – a company limited by guarantee and having a share capital

H – a company limited by guarantee and not having share capital)

F - A COMPANY LIMITED BY SHARES

The name of the company is

KALLAM TRANSCO LIMITED

Check if not applicable	Check if altered	Article No.	Description
			Interpretation
<input type="checkbox"/>	<input checked="" type="checkbox"/>	I	<ul style="list-style-type: none"> (1) In these regulations- (a) the Act means the Companies Act 2013 (b) the seal means the common seal of the company. (2) Unless the context otherwise requires words or expressions contained in these regulations shall bear the same meaning as in the Act or any statutory modification thereof in force at the date at which these regulations become binding on the company. (3) Public company means a company which- (a) is not a private company (b) has a minimum paid-up share capital as may be prescribed Provided that a company which is a subsidiary of a company not being a private company shall be deemed to be public company for the purposes of this Act even where such subsidiary company continues to be a private company in its articles.
			Share Capital and Variation of rights
<input type="checkbox"/>	<input type="checkbox"/>	II 1	<ul style="list-style-type: none"> Subject to the provisions of the Act and these Articles the shares in the capital of the company shall be under the control of the Directors who may issue allot or otherwise dispose of the same or any of them to such persons in such proportion and on such terms and conditions and either at a premium or at par and at such time as they may from time to time think fit.
<input type="checkbox"/>	<input checked="" type="checkbox"/>		<ul style="list-style-type: none"> Every person whose name is entered as a member in the register

	2	<p>of members shall be entitled to receive within two months after incorporation in case of subscribers to the memorandum or after allotment or within one month after the application for the registration of transfer or transmission or within such other period as the conditions of issue shall be provided one certificate for all his shares without payment of any charges or several certificates each for one or more of his shares upon payment of twenty rupees for each certificate after the first. Every certificate shall be under the seal and shall specify the shares to which it relates and the amount paid - up thereon. In respect of any share or shares held jointly by several persons the company shall not be bound to issue more than one certificate and delivery of certificate for a share to one of several joint holders shall be sufficient delivery to all such holders.</p>	
<input type="checkbox"/>	<input type="checkbox"/>	3	<ul style="list-style-type: none"> If any share certificate be worn out defaced mutilated or torn or if there be no further space on the back for endorsement of transfer then upon production and surrender thereof to the company a new certificate may be issued in lieu thereof and if any certificate is lost or destroyed then upon proof thereof to the satisfaction of the company and on execution of such indemnity as the company deem adequate a new certificate in lieu thereof shall be given. Every certificate under this Article shall be issued on payment of twenty rupees for each certificate. The provisions of Articles (2) and (3) shall mutatis mutandis apply to debentures of the company.
<input type="checkbox"/>	<input type="checkbox"/>	4	<ul style="list-style-type: none"> Except as required by law no person shall be recognised by the company as holding any share upon any trust and the company shall not be bound by or be compelled in any way to recognise (even when having notice thereof) any equitable contingent future or partial interest in any share or any interest in any fractional part of a share or (except only as by these regulations or by law otherwise provided) any other rights in respect of any share except an absolute right to the entirety thereof in the registered holder.
<input type="checkbox"/>	<input type="checkbox"/>	5	<ul style="list-style-type: none"> The company may exercise the powers of paying commissions conferred by sub-section (6) of section 40 provided that the rate per cent or the amount of the commission paid or agreed to be paid shall be disclosed in the manner required by that section and rules made thereunder. The rate or amount of the commission shall not exceed the rate or amount prescribed in rules made under sub-section (6) of section 40. The commission may be satisfied by the payment of cash or the allotment of fully or partly paid shares or partly in the one way and partly in the other.
<input type="checkbox"/>	<input type="checkbox"/>	6	<ul style="list-style-type: none"> If at any time the share capital is divided into different classes of shares the rights attached to any class (unless otherwise provided by the terms of issue of the shares of that class) may subject to the provisions of section 48 and whether or not the company is being wound up be varied with the consent in writing of the holders of three-fourths of the issued shares of that class or with the sanction of a special resolution passed at a separate meeting of the holders of the shares of that class. To every such separate meeting the provisions of these regulations relating to general meetings shall mutatis mutandis apply but so that the necessary quorum shall be at least two persons holding at least one-third of the issued shares

			of the class in question.
<input type="checkbox"/>	<input type="checkbox"/>	7	<ul style="list-style-type: none"> The rights conferred upon the holders of the shares of any class issued with preferred or other rights shall not unless otherwise expressly provided by the terms of issue of the shares of that class be deemed to be varied by the creation or issue of further shares ranking pari passu therewith.
<input type="checkbox"/>	<input type="checkbox"/>	8	<ul style="list-style-type: none"> Subject to the provisions of section 55 any preference shares may with the sanction of an ordinary resolution be issued on the terms that they are to be redeemed on such terms and in such manner as the company before the issue of the shares may by special resolution determine.
			Lien
<input type="checkbox"/>	<input type="checkbox"/>	9	<ul style="list-style-type: none"> The company shall have a first and paramount lien on every share (not being a fully paid share) for all monies (whether presently payable or not) called or payable at a fixed time in respect of that share and on all shares (not being fully paid shares) standing registered in the name of a single person for all monies presently payable by him or his estate to the company Provided that the Board of directors may at any time declare any share to be wholly or in part exempt from the provisions of this clause. The company's lien if any on a share shall extend to all dividends payable and bonuses declared from time to time in respect of such shares.
<input type="checkbox"/>	<input type="checkbox"/>	10	<ul style="list-style-type: none"> The company may sell in such manner as the Board thinks fit any shares on which the company has a lien Provided that no sale shall be made unless a sum in respect of which the lien exists is presently payable or until the expiration of fourteen days after a notice in writing stating and demanding payment of such part of the amount in respect of which the lien exists as is presently payable has been given to the registered holder for the time being of the share or the person entitled thereto by reason of his death or insolvency.
<input type="checkbox"/>	<input type="checkbox"/>	11	<ul style="list-style-type: none"> To give effect to any such sale the Board may authorise some person to transfer the shares sold to the purchaser thereof The purchaser shall be registered as the holder of the shares comprised in any such transfer. The purchaser shall not be bound to see to the application of the purchase money nor shall his title to the shares be affected by any irregularity or invalidity in the proceedings in reference to the sale.
<input type="checkbox"/>	<input type="checkbox"/>	12	<ul style="list-style-type: none"> The proceeds of the sale shall be received by the company and applied in payment of such part of the amount in respect of which the lien exists as is presently payable. The residue if any shall subject to a like lien for sums not presently payable as existed upon the shares before the sale be paid to the person entitled to the shares at the date of the sale.
			Calls on shares
<input type="checkbox"/>	<input type="checkbox"/>		<ul style="list-style-type: none"> The Board may from time to time make calls upon the members in respect of any monies unpaid on their shares (whether on account

		13	of the nominal value of the shares or by way of premium) and not by the conditions of allotment thereof made payable at fixed times Provided that no call shall exceed one-fourth of the nominal value of the share or be payable at less than one month from the date fixed for the payment of the last preceding call. Each member shall subject to receiving at least fourteen days notice specifying the time or times and place of payment pay to the company at the time or times and place so specified the amount called on his shares. A call may be revoked or postponed at the discretion of the Board.
<input type="checkbox"/>	<input type="checkbox"/>	14	<ul style="list-style-type: none"> A call shall be deemed to have been made at the time when the resolution of the Board authorizing the call was passed and may be required to be paid by instalments.
<input type="checkbox"/>	<input type="checkbox"/>	15	<ul style="list-style-type: none"> The joint holders of a share shall be jointly and severally liable to pay all calls in respect thereof.
<input type="checkbox"/>	<input type="checkbox"/>	16	<ul style="list-style-type: none"> If a sum called in respect of a share is not paid before or on the day appointed for payment thereof the person from whom the sum is due shall pay interest thereon from the day appointed for payment thereof to the time of actual payment at ten per cent per annum or at such lower rate if any as the Board may determine. The Board shall be at liberty to waive payment of any such interest wholly or in part.
<input type="checkbox"/>	<input type="checkbox"/>	17	<ul style="list-style-type: none"> Any sum which by the terms of issue of a share becomes payable on allotment or at any fixed date whether on account of the nominal value of the share or by way of premium shall for the purposes of these regulations be deemed to be a call duly made and payable on the date on which by the terms of issue such sum becomes payable. In case of non-payment of such sum all the relevant provisions of these regulations as to payment of interest and expenses forfeiture or otherwise shall apply as if such sum had become payable by virtue of a call duly made and notified.
<input type="checkbox"/>	<input type="checkbox"/>	18	<ul style="list-style-type: none"> The Board - a. may if it thinks fit receive from any member willing to advance the same all or any part of the monies uncalled and unpaid upon any shares held by him and b. upon all or any of the monies so advanced may (until the same would but for such advance become presently payable) pay interest at such rate not exceeding unless the company in general meeting shall otherwise direct twelve per cent per annum as may be agreed upon between the Board and the member paying the sum in advance.
			<i>Transfer of shares</i>
<input type="checkbox"/>	<input type="checkbox"/>	19	<ul style="list-style-type: none"> The instrument of transfer of any share in the company shall be executed by or on behalf of both the transferor and transferee. The transferor shall be deemed to remain a holder of the share until the name of the transferee is entered in the register of members in respect thereof.
<input type="checkbox"/>	<input type="checkbox"/>	20	<ul style="list-style-type: none"> The Board may subject to the right of appeal conferred by section 58 decline to register the transfer of a share not being a fully paid share to a person of whom they do not approve or any transfer of

			shares on which the company has a lien.
<input type="checkbox"/>	<input type="checkbox"/>	21	<ul style="list-style-type: none"> The Board may decline to recognise any instrument of transfer unless the instrument of transfer is in the form as prescribed in rules made under sub-section (1) of section 56b. the instrument of transfer is accompanied by the certificate of the shares to which it relates and such other evidence as the Board may reasonably require to show the right of the transferor to make the transfer andc. the instrument of transfer is in respect of only one class of shares.
<input type="checkbox"/>	<input type="checkbox"/>	22	<ul style="list-style-type: none"> On giving not less than seven days previous notice in accordance with section 91 and rules made thereunder the registration of transfers may be suspended at such times and for such periods as the Board may from time to time determineProvided that such registration shall not be suspended for more than thirty days at any one time or for more than forty-five days in the aggregate in any year.
			Transmission of shares
<input type="checkbox"/>	<input type="checkbox"/>	23	<ul style="list-style-type: none"> On the death of a member the survivor or survivors where the member was a joint holder and his nominee or nominees or legal representatives where he was a sole holder shall be the only persons recognised by the company as having any title to his interest in the shares Nothing in clause (i) shall release the estate of a deceased joint holder from any liability in respect of any share which had been jointly held by him with other persons.
<input type="checkbox"/>	<input type="checkbox"/>	24	<ul style="list-style-type: none"> Any person becoming entitled to a share in consequence of the death or insolvency of a member may upon such evidence being produced as may from time to time properly be required by the Board and subject as hereinafter provided elect either to be registered himself as holder of the share or to make such transfer of the share as the deceased or insolvent member could have made. The Board shall in either case have the same right to decline or suspend registration as it would have had if the deceased or insolvent member had transferred the share before his death or insolvency.
<input type="checkbox"/>	<input type="checkbox"/>	25	<ul style="list-style-type: none"> If the person so becoming entitled shall elect to be registered as holder of the share himself he shall deliver or send to the company a notice in writing signed by him stating that he so elects. If the person aforesaid shall elect to transfer the share he shall testify his election by executing a transfer of the share. All the limitations restrictions and provisions of these regulations relating to the right to transfer and the registration of transfers of shares shall be applicable to any such notice or transfer as aforesaid as if the death or insolvency of the member had not occurred and the notice or transfer were a transfer signed by that member.
<input type="checkbox"/>	<input type="checkbox"/>		<ul style="list-style-type: none"> A person becoming entitled to a share by reason of the death or insolvency of the holder shall be entitled to the same dividends and other advantages to which he would be entitled if he were the registered holder of the share except that he shall not before being registered as a member in respect of the share be entitled in

		26	respect of it to exercise any right conferred by membership in relation to meetings of the company Provided that the Board may at any time give notice requiring any such person to elect either to be registered himself or to transfer the share and if the notice is not complied with within ninety days the Board may thereafter withhold payment of all dividends bonuses or other monies payable in respect of the share until the requirements of the notice have been complied with.
<input checked="" type="checkbox"/>	<input type="checkbox"/>	27	<ul style="list-style-type: none"> In case of a One Person Company on the death of the sole member the person nominated by such member shall be the person recognised by the company as having title to all the shares of the member the nominee on becoming entitled to such shares in case of the members death shall be informed of such event by the Board of the company such nominee shall be entitled to the same dividends and other rights and liabilities to which such sole member of the company was entitled or liable on becoming member such nominee shall nominate any other person with the prior written consent of such person who shall in the event of the death of the member become the member of the company.
			<i>Forfeiture of shares</i>
<input type="checkbox"/>	<input type="checkbox"/>	28	<ul style="list-style-type: none"> If a member fails to pay any call or instalment of a call on the day appointed for payment thereof the Board may at any time thereafter during such time as any part of the call or instalment remains unpaid serve a notice on him requiring payment of so much of the call or instalment as is unpaid together with any interest which may have accrued.
<input type="checkbox"/>	<input type="checkbox"/>	29	<ul style="list-style-type: none"> The notice aforesaid shall name a further day (not being earlier than the expiry of fourteen days from the date of service of the notice) on or before which the payment required by the notice is to be made and state that in the event of non-payment on or before the day so named the shares in respect of which the call was made shall be liable to be forfeited.
<input type="checkbox"/>	<input type="checkbox"/>	30	<ul style="list-style-type: none"> If the requirements of any such notice as aforesaid are not complied with any share in respect of which the notice has been given may at any time thereafter before the payment required by the notice has been made be forfeited by a resolution of the Board to that effect.
<input type="checkbox"/>	<input type="checkbox"/>	31	<ul style="list-style-type: none"> A forfeited share may be sold or otherwise disposed of on such terms and in such manner as the Board thinks fit. At any time before a sale or disposal as aforesaid the Board may cancel the forfeiture on such terms as it thinks fit.
<input type="checkbox"/>	<input type="checkbox"/>	32	<ul style="list-style-type: none"> A person whose shares have been forfeited shall cease to be a member in respect of the forfeited shares but shall notwithstanding the forfeiture remain liable to pay to the company all monies which at the date of forfeiture were presently payable by him to the company in respect of the shares. The liability of such person shall cease if and when the company shall have received payment in full of all such monies in respect of the shares.
			<ul style="list-style-type: none"> A duly verified declaration in writing that the declarant is a director

<input type="checkbox"/>	<input type="checkbox"/>	33	<p>the manager or the secretary of the company and that a share in the company has been duly forfeited on a date stated in the declaration shall be conclusive evidence of the facts therein stated as against all persons claiming to be entitled to the share The company may receive the consideration if any given for the share on any sale or disposal thereof and may execute a transfer of the share in favour of the person to whom the share is sold or disposed of The transferee shall thereupon be registered as the holder of the share and The transferee shall not be bound to see to the application of the purchase money if any nor shall his title to the share be affected by any irregularity or invalidity in the proceedings in reference to the forfeiture sale or disposal of the share.</p>
<input type="checkbox"/>	<input type="checkbox"/>		
<input type="checkbox"/>	<input type="checkbox"/>	34	<ul style="list-style-type: none"> The provisions of these regulations as to forfeiture shall apply in the case of non-payment of any sum which by the terms of issue of a share becomes payable at a fixed time whether on account of the nominal value of the share or by way of premium as if the same had been payable by virtue of a call duly made and notified.
<input type="checkbox"/>	<input type="checkbox"/>		
			<i>Alteration of capital</i>
<input type="checkbox"/>	<input type="checkbox"/>	35	<ul style="list-style-type: none"> The company may from time to time by ordinary resolution increase the share capital by such sum to be divided into shares of such amount as may be specified in the resolution.
<input type="checkbox"/>	<input type="checkbox"/>		
<input type="checkbox"/>	<input type="checkbox"/>	36	<ul style="list-style-type: none"> Subject to the provisions of section 61 the company may by ordinary resolution consolidate and divide all or any of its share capital into shares of larger amount than its existing shares convert all or any of its fully paid-up shares into stock and reconvert that stock into fully paid-up shares of any denomination sub-divide its existing shares or any of them into shares of smaller amount than is fixed by the memorandum cancel any shares which at the date of the passing of the resolution have not been taken or agreed to be taken by any person.
<input type="checkbox"/>	<input type="checkbox"/>		
<input type="checkbox"/>	<input type="checkbox"/>	37	<ul style="list-style-type: none"> Where shares are converted into stock the holders of stock may transfer the same or any part thereof in the same manner as and subject to the same regulations under which the shares from which the stock arose might before the conversion have been transferred or as near thereto as circumstances admit Provided that the Board may from time to time fix the minimum amount of stock transferable so however that such minimum shall not exceed the nominal amount of the shares from which the stock arose. the holders of stock shall according to the amount of stock held by them have the same rights privileges and advantages as regards dividends voting at meetings of the company and other matters as if they held the shares from which the stock arose but no such privilege or advantage (except participation in the dividends and profits of the company and in the assets on winding up) shall be conferred by an amount of stock which would not if existing in shares have conferred that privilege or advantage. such of the regulations of the company as are applicable to paid-up shares shall apply to stock and the words share and shareholder in those regulations shall include stock and stock-holder respectively.
<input type="checkbox"/>	<input type="checkbox"/>		

<input type="checkbox"/>	<input type="checkbox"/>	38	<ul style="list-style-type: none"> The company may by special resolution reduce in any manner and with and subject to any incident authorised and consent required by law its share capital any capital redemption reserve account or any share premium account.
			Capitalisation of profits
<input type="checkbox"/>	<input type="checkbox"/>	39	<ul style="list-style-type: none"> The company in general meeting may upon the recommendation of the Board resolve that it is desirable to capitalise any part of the amount for the time being standing to the credit of any of the company's reserve accounts or to the credit of the profit and loss account otherwise available for distribution and that such sum be accordingly set free for distribution in the manner specified in clause (ii) amongst the members who would have been entitled thereto if distributed by way of dividend and in the same proportions. The sum aforesaid shall not be paid in cash but shall be applied subject to the provision contained in clause (iii) either in or towards paying up any amounts for the time being unpaid on any shares held by such members respectively paying up in full unissued shares of the company to be allotted and distributed credited as fully paid-up to and amongst such members in the proportions aforesaid partly in the way specified in sub-clause (A) and partly in that specified in sub-clause (B) A securities premium account and a capital redemption reserve account may for the purposes of this regulation be applied in the paying up of unissued shares to be issued to members of the company as fully paid bonus shares The Board shall give effect to the resolution passed by the company in pursuance of this regulation.
<input type="checkbox"/>	<input type="checkbox"/>	40	<ul style="list-style-type: none"> Whenever such a resolution as aforesaid shall have been passed the Board shall make all appropriations and applications of the undivided profits resolved to be capitalised thereby and all allotments and issues of fully paid shares if any and generally do all acts and things required to give effect thereto. The Board shall have power to make such provisions by the issue of fractional certificates or by payment in cash or otherwise as it thinks fit for the case of shares becoming distributable in fractions and to authorise any person to enter on behalf of all the members entitled thereto into an agreement with the company providing for the allotment to them respectively credited as fully paid-up of any further shares to which they may be entitled upon such capitalisation or as the case may require for the payment by the company on their behalf by the application thereto of their respective proportions of profits resolved to be capitalised of the amount or any part of the amounts remaining unpaid on their existing shares Any agreement made under such authority shall be effective and binding on such members
			Buy-back of shares
<input type="checkbox"/>	<input type="checkbox"/>	41	<ul style="list-style-type: none"> Notwithstanding anything contained in these articles but subject to the provisions of sections 68 to 70 and any other applicable provision of the Act or any other law for the time being in force the company may purchase its own shares or other specified securities.

			General meetings
<input type="checkbox"/>	<input type="checkbox"/>	42	<ul style="list-style-type: none"> All general meetings other than annual general meeting shall be called extraordinary general meeting.
<input type="checkbox"/>	<input type="checkbox"/>	43	<ul style="list-style-type: none"> The Board may whenever it thinks fit call an extraordinary general meeting. If at any time directors capable of acting who are sufficient in number to form a quorum are not within India any director or any two members of the company may call an extraordinary general meeting in the same manner as nearly as possible as that in which such a meeting may be called by the Board.
			Proceedings at general meetings
<input type="checkbox"/>	<input type="checkbox"/>	44	<ul style="list-style-type: none"> No business shall be transacted at any general meeting unless a quorum of members is present at the time when the meeting proceeds to business. Save as otherwise provided herein the quorum for the general meetings shall be as provided in section 103.
<input type="checkbox"/>	<input type="checkbox"/>	45	<ul style="list-style-type: none"> The chairperson if any of the Board shall preside as Chairperson at every general meeting of the company.
<input type="checkbox"/>	<input type="checkbox"/>	46	<ul style="list-style-type: none"> If there is no such Chairperson or if he is not present within fifteen minutes after the time appointed for holding the meeting or is unwilling to act as chairperson of the meeting the directors present shall elect one of their members to be Chairperson of the meeting.
<input type="checkbox"/>	<input type="checkbox"/>	47	<ul style="list-style-type: none"> If at any meeting no director is willing to act as Chairperson or if no director is present within fifteen minutes after the time appointed for holding the meeting the members present shall choose one of their members to be Chairperson of the meeting.
<input checked="" type="checkbox"/>	<input type="checkbox"/>	48	<ul style="list-style-type: none"> In case of a One Person Company the resolution required to be passed at the general meetings of the company shall be deemed to have been passed if the resolution is agreed upon by the sole member and communicated to the company and entered in the minutes book maintained under section 118 such minutes book shall be signed and dated by the member the resolution shall become effective from the date of signing such minutes by the sole member.
			Adjournment of meeting
<input type="checkbox"/>	<input type="checkbox"/>	49	<ul style="list-style-type: none"> The Chairperson may with the consent of any meeting at which a quorum is present and shall if so directed by the meeting adjourn the meeting from time to time and from place to place. No business shall be transacted at any adjourned meeting other than the business left unfinished at the meeting from which the adjournment took place. When a meeting is adjourned for thirty days or more notice of the adjourned meeting shall be given as in the case of an original meeting. Save as aforesaid and as provided in section 103 of the Act it shall not be necessary to give any notice of an adjournment or of the business to be transacted at an

adjourned meeting.

			Voting rights
<input type="checkbox"/>	<input type="checkbox"/>	50	<ul style="list-style-type: none"> Subject to any rights or restrictions for the time being attached to any class or classes of shares on a show of hands every member present in person shall have one vote and on a poll the voting rights of members shall be in proportion to his share in the paid-up equity share capital of the company.
<input type="checkbox"/>	<input type="checkbox"/>	51	<ul style="list-style-type: none"> A member may exercise his vote at a meeting by electronic means in accordance with section 108 and shall vote only once.
<input type="checkbox"/>	<input type="checkbox"/>	52	<ul style="list-style-type: none"> In the case of joint holders the vote of the senior who tenders a vote whether in person or by proxy shall be accepted to the exclusion of the votes of the other joint holders. For this purpose seniority shall be determined by the order in which the names stand in the register of members.
<input type="checkbox"/>	<input type="checkbox"/>	53	<ul style="list-style-type: none"> A member of unsound mind or in respect of whom an order has been made by any court having jurisdiction in lunacy may vote whether on a show of hands or on a poll by his committee or other legal guardian and any such committee or guardian may on a poll vote by proxy.
<input type="checkbox"/>	<input type="checkbox"/>	54	<ul style="list-style-type: none"> Any business other than that upon which a poll has been demanded maybe proceeded with pending the taking of the poll.
<input type="checkbox"/>	<input type="checkbox"/>	55	<ul style="list-style-type: none"> No member shall be entitled to vote at any general meeting unless all calls or other sums presently payable by him in respect of shares in the company have been paid
<input type="checkbox"/>	<input type="checkbox"/>	56	<ul style="list-style-type: none"> No objection shall be raised to the qualification of any voter except at the meeting or adjourned meeting at which the vote objected to is given or tendered and every vote not disallowed at such meeting shall be valid for all purposes. Any such objection made in due time shall be referred to the Chairperson of the meeting whose decision shall be final and conclusive.
			Proxy
<input type="checkbox"/>	<input type="checkbox"/>	57	<ul style="list-style-type: none"> The instrument appointing a proxy and the power-of-attorney or other authority if any under which it is signed or a notarised copy of that power or authority shall be deposited at the registered office of the company not less than 48 hours before the time for holding the meeting or adjourned meeting at which the person named in the instrument proposes to vote or in the case of a poll not less than 24 hours before the time appointed for the taking of the poll and in default the instrument of proxy shall not be treated as valid.
<input type="checkbox"/>	<input type="checkbox"/>	58	<ul style="list-style-type: none"> An instrument appointing a proxy shall be in the form as prescribed in the rules made under section 105
<input type="checkbox"/>	<input type="checkbox"/>		<ul style="list-style-type: none"> A vote given in accordance with the terms of an instrument of proxy shall be valid notwithstanding the previous death or insanity

	59	<p>of the principal or the revocation of the proxy or of the authority under which the proxy was executed or the transfer of the shares in respect of which the proxy is given Provided that no intimation in writing of such death insanity revocation or transfer shall have been received by the company at its office before the commencement of the meeting or adjourned meeting at which the proxy is used.</p>
		<p>Board of Directors</p>
<input type="checkbox"/>	<input checked="" type="checkbox"/>	<p>• The day to day management of the business of the Company shall be vested with the Board of Directors of the Company or such persons as may be authorized by the Board from time to time. The Board may exercise all such powers of the Company and do all such acts, deeds and things as are not prohibited by the Act or any other law for the time being in force or by the Memorandum of Association of the Company and without prejudice to the foregoing shall be responsible for all policy matters and the supervision, direction and control of the conduct of the business affairs and operations of the Company. i. The first Directors of the Company shall be 1. AJAYMATHUR 2. ALOK SINGH 3. MUKUL AGARWAL ii. At every annual general meeting one third of such of the directors for the time being as are liable to retire by rotation or if their number is neither three nor a multiple of three then the number nearest to one third shall retire from office. The directors to retire by rotation at every annual general meeting shall be those who have been longest in office since their last appointment but as between persons who became directors on the same day those who are to retire shall in default of and subject to any agreement among themselves be determined by lot. At annual general meeting at which a director retires as aforesaid the company may fill up the vacancy by appointing there retiring director or some other person there to. The Board of Directors of the Company shall consist of not less than but not more than Directors. The appointment of Directors including the Chairman, Managing Director, Whole time Director, Part time Director shall be done in the General Meetings in accordance with the provisions of the Companies Act and Rules made there under and shall be eligible for appointment. However till the Company is a Government Company REC Power Development and Consultancy Limited (RECPDCL) the holding company shall have the full powers to recommend and nominate the name of any Directors to be appointed on the Board of the Company. Further RECPDCL shall also have the power to remove any director from office at any time in its absolute discretion. RECPDCL shall also have the right to fill any vacancies in the office of director caused by removal, resignation, death or otherwise. Subject to provisions of the Act, the Company may, by passing a resolution in General Meeting, increase or decrease the maximum number of Directors and may alter their qualification. Further, the Company may, subject to the provisions of the Act, remove any Director before the expiration of his period of office and appoint another person in place of him. The Board may appoint any person to act as alternate director for a Director during the latter's absence for a period of not less than three months from India and such appointment shall have effect and such appointee whilst he holds office as an alternate director shall be entitled to notice of meeting of the Board and to attend and vote there at accordingly but he shall not require any qualification and shall ipso facto vacate office if and when the absent Director returns to India.</p>
	60	

			Casualvacanciesamong Directors may be filled by the Board of Directors attheirmeeting and any person so appointed shall hold the office asperthe provision of section of the Act Subject to the provisions ofSectionand other applicable provisions if any of the Act the Boardshallhave power at any time and from time to time to appointaperson as an Additional Director but so that the total number ofDirectorsshall not at any time exceed the maximum number fixedbythese Articles The Additional Director so appointed shall retirefromOffice at next annual General Meeting but shall be eligible forelectionby the company at that meeting as a Director
<input type="checkbox"/>	<input type="checkbox"/>	61	<ul style="list-style-type: none"> The remuneration of the directors shall in so far as it consists of a monthly payment be deemed to accrue from day-to-day. In addition to the remuneration payable to them in pursuance of the Act the directors may be paid all travelling hotel and other expenses properly incurred by them in attending and returning from meetings of the Board of Directors or any committee thereof or general meetings of the company or in connection with the business of the company.
<input type="checkbox"/>	<input type="checkbox"/>	62	<ul style="list-style-type: none"> The Board may pay all expenses incurred in getting up and registering the company.
<input type="checkbox"/>	<input type="checkbox"/>	63	<ul style="list-style-type: none"> The company may exercise the powers conferred on it by section 88 with regard to the keeping of a foreign register and the Board may (subject to the provisions of that section) make and vary such regulations as it may think fit respecting the keeping of any such register.
<input type="checkbox"/>	<input type="checkbox"/>	64	<ul style="list-style-type: none"> All cheques promissory notes drafts hundis bills of exchange and other negotiable instruments and all receipts for monies paid to the company shall be signed drawn accepted endorsed or otherwise executed as the case may be by such person and in such manner as the Board shall from time to time by resolution determine
<input type="checkbox"/>	<input type="checkbox"/>	65	<ul style="list-style-type: none"> Every director present at any meeting of the Board or of a committee thereof shall sign his name in a book to be kept for that purpose.
<input type="checkbox"/>	<input type="checkbox"/>	66	<ul style="list-style-type: none"> Subject to the provisions of section 149 the Board shall have power at any time and from time to time to appoint a person as an additional director provided the number of the directors and additional directors together shall not at any time exceed the maximum strength fixed for the Board by the articles. Such person shall hold office only up to the date of the next annual general meeting of the company but shall be eligible for appointment by the company as a director at that meeting subject to the provisions of the Act.
			<i>Proceedings of the Board</i>
<input type="checkbox"/>	<input type="checkbox"/>	67	<ul style="list-style-type: none"> The Board of Directors may meet for the conduct of business adjourn and otherwise regulate its meetings as it thinks fit. A director may and the manager or secretary on the requisition of a director shall at any time summon a meeting of the Board.

<input type="checkbox"/>	<input type="checkbox"/>	68	<ul style="list-style-type: none"> Save as otherwise expressly provided in the Act questions arising at any meeting of the Board shall be decided by a majority of votes. In case of an equality of votes the Chairperson of the Board if any shall have a second or casting vote.
<input type="checkbox"/>	<input type="checkbox"/>	69	<ul style="list-style-type: none"> The continuing directors may act notwithstanding any vacancy in the Board but if and so long as their number is reduced below the quorum fixed by the Act for a meeting of the Board the continuing directors or director may act for the purpose of increasing the number of directors to that fixed for the quorum or of summoning a general meeting of the company but for no other purpose.
<input type="checkbox"/>	<input type="checkbox"/>	70	<ul style="list-style-type: none"> The Board may elect a Chairperson of its meetings and determine the period for which he is to hold office. If no such Chairperson is elected or if at any meeting the Chairperson is not present within five minutes after the time appointed for holding the meeting the directors present may choose one of their number to be Chairperson of the meeting.
<input type="checkbox"/>	<input type="checkbox"/>	71	<ul style="list-style-type: none"> The Board may subject to the provisions of the Act delegate any of its powers to committees consisting of such member or members of its body as it thinks fit. Any committee so formed shall in the exercise of the powers so delegated conform to any regulations that may be imposed on it by the Board.
<input type="checkbox"/>	<input type="checkbox"/>	72	<ul style="list-style-type: none"> A committee may elect a Chairperson of its meetings. If no such Chairperson is elected or if at any meeting the Chairperson is not present within five minutes after the time appointed for holding the meeting the members present may choose one of their members to be Chairperson of the meeting.
<input type="checkbox"/>	<input type="checkbox"/>	73	<ul style="list-style-type: none"> A committee may meet and adjourn as it thinks fit. Questions arising at any meeting of a committee shall be determined by a majority of votes of the members present and in case of an equality of votes the Chairperson shall have a second or casting vote.
<input type="checkbox"/>	<input type="checkbox"/>	74	<ul style="list-style-type: none"> All acts done in any meeting of the Board or of a committee thereof or by any person acting as a director shall notwithstanding that it may be afterwards discovered that there was some defect in the appointment of any one or more of such directors or of any person acting as aforesaid or that they or any of them were disqualified be as valid as if every such director or such person had been duly appointed and was qualified to be a director.
<input type="checkbox"/>	<input type="checkbox"/>	75	<ul style="list-style-type: none"> Save as otherwise expressly provided in the Act a resolution in writing signed by all the members of the Board or of a committee thereof for the time being entitled to receive notice of a meeting of the Board or committee shall be valid and effective as if it had been passed at a meeting of the Board or committee duly convened and held.
<input checked="" type="checkbox"/>	<input type="checkbox"/>	76	<ul style="list-style-type: none"> In case of a One Person Company where the company is having only one director all the businesses to be transacted at the meeting of the Board shall be entered into minutes book maintained under section 118 such minutes book shall be signed and dated by the director the resolution shall become effective from the date of

			signing such minutes by the director.
			Chief Executive Officer, Manager, Company Secretary or Chief Financial Officer
<input type="checkbox"/>	<input type="checkbox"/>	77	<ul style="list-style-type: none"> Subject to the provisions of the Act a chief executive officer manager company secretary or chief financial officer may be appointed by the Board for such term at such remuneration and upon such conditions as it may think fit and any chief executive officer manager company secretary or chief financial officer so appointed may be removed by means of a resolution of the Board A director may be appointed as chief executive officer manager company secretary or chief financial officer
<input type="checkbox"/>	<input type="checkbox"/>	78	<ul style="list-style-type: none"> A provision of the Act or these regulations requiring or authorising a thing to be done by or to a director and chief executive officer manager company secretary or chief financial officer shall not be satisfied by its being done by or to the same person acting both as director and as or in place of chief executive officer manager company secretary or chief financial officer.
			The Seal
<input type="checkbox"/>	<input type="checkbox"/>	79	<ul style="list-style-type: none"> The Board shall provide for the safe custody of the seal. The seal of the company shall not be affixed to any instrument except by the authority of a resolution of the Board or of a committee of the Board authorised by it in that behalf and except in the presence of at least two directors and of the secretary or such other person as the Board may appoint for the purpose and those two directors and the secretary or other person aforesaid shall sign every instrument to which the seal of the company is so affixed in their presence.
			Dividends and Reserve
<input type="checkbox"/>	<input type="checkbox"/>	80	<ul style="list-style-type: none"> The company in general meeting may declare dividends but no dividend shall exceed the amount recommended by the Board.
<input type="checkbox"/>	<input type="checkbox"/>	81	<ul style="list-style-type: none"> Subject to the provisions of section 123 the Board may from time to time pay to the members such interim dividends as appear to it to be justified by the profits of the company.
<input type="checkbox"/>	<input type="checkbox"/>	82	<ul style="list-style-type: none"> The Board may before recommending any dividend set aside out of the profits of the company such sums as it thinks fit as a reserve or reserves which shall at the discretion of the Board be applicable for any purpose to which the profits of the company may be properly applied including provision for meeting contingencies or for equalizing dividends and pending such application may at the like discretion either be employed in the business of the company or be invested in such investments (other than shares of the company) as the Board may from time to time thinks fit. The Board may also carry forward any profits which it may consider necessary not to divide without setting them aside as a reserve
<input type="checkbox"/>	<input type="checkbox"/>		<ul style="list-style-type: none"> Subject to the rights of persons if any entitled to shares with special rights as to dividends all dividends shall be declared and paid according to the amounts paid or credited as paid on the shares in

		83	<p>respect whereof the dividend is paid but if and so long as nothing is paid upon any of the shares in the company dividends may be declared and paid according to the amounts of the shares. No amount paid or credited as paid on a share in advance of calls shall be treated for the purposes of this regulation as paid on the share. All dividends shall be apportioned and paid proportionately to the amounts paid or credited as paid on the shares during any portion or portions of the period in respect of which the dividend is paid but if any share is issued on terms providing that it shall rank for dividend as from a particular date such share shall rank for dividend accordingly.</p>
<input type="checkbox"/>	<input type="checkbox"/>	84	<ul style="list-style-type: none"> The Board may deduct from any dividend payable to any member all sums of money if any presently payable by him to the company on account of calls or otherwise in relation to the shares of the company.
<input type="checkbox"/>	<input type="checkbox"/>	85	<ul style="list-style-type: none"> Any dividend interest or other monies payable in cash in respect of shares may be paid by cheque or warrant sent through the post directed to the registered address of the holder or in the case of joint holders to the registered address of that one of the joint holders who is first named on the register of members or to such person and to such address as the holder or joint holders may in writing direct. Every such cheque or warrant shall be made payable to the order of the person to whom it is sent.
<input type="checkbox"/>	<input type="checkbox"/>	86	<ul style="list-style-type: none"> Any one of two or more joint holders of a share may give effective receipts for any dividends bonuses or other monies payable in respect of such share.
<input type="checkbox"/>	<input type="checkbox"/>	87	<ul style="list-style-type: none"> Notice of any dividend that may have been declared shall be given to the persons entitled to share therein in the manner mentioned in the Act.
<input type="checkbox"/>	<input type="checkbox"/>	88	<ul style="list-style-type: none"> No dividend shall bear interest against the company.
			Accounts
<input type="checkbox"/>	<input type="checkbox"/>	89	<ul style="list-style-type: none"> The Board shall from time to time determine whether and to what extent and at what times and places and under what conditions or regulations the accounts and books of the company or any of them shall be open to the inspection of members not being directors. No member (not being a director) shall have any right of inspecting any account or book or document of the company except as conferred by law or authorised by the Board or by the company in general meeting.
			Winding up
<input type="checkbox"/>	<input type="checkbox"/>		<ul style="list-style-type: none"> Subject to the provisions of Chapter XX of the Act and rules made thereunder If the company shall be wound up the liquidator may with the sanction of a special resolution of the company and any other sanction required by the Act divide amongst the members in specie or kind the whole or any part of the assets of the company whether they shall consist of property of the same kind or not. For the purpose aforesaid the liquidator may set such value as he

		90	deems fair upon any property to be divided as aforesaid and may determine how such division shall be carried out as between the members or different classes of members. The liquidator may with the like sanction vest the whole or any part of such assets in trustees upon such trusts for the benefit of the contributories if he considers necessary but so that no member shall be compelled to accept any shares or other securities whereon there is any liability.
			Indemnity
<input type="checkbox"/>	<input type="checkbox"/>	91	<ul style="list-style-type: none"> • Every officer of the company shall be indemnified out of the assets of the company against any liability incurred by him in defending any proceedings whether civil or criminal in which judgment is given in his favour or in which he is acquitted or in which relief is granted to him by the court or the Tribunal.
			Others
<input type="checkbox"/>	<input type="checkbox"/>	92	•

Subscriber Details

S. No.	Subscriber Details				
	*Name, Address, Description and Occupation	DIN / PAN / Passport number	*Place	DSC	Dated
1	REC POWER DEVELOPMENT AND CONSULTANCY LIMITED, CORE-4, SCOPE COMPLEX, 7, LODHI ROAD, NEW DELHI-110003, THROUGH ITS CEO RAJESH KUMAR S/O SHRINIWAS GUPTA R/O L-187, NAG MANDIR KE PAS SHASTRI NAGAR, ASHOK VIHAR, DELHI-110052, OCCUPATION-SERVICES	06941428	NEW DELHI		05/09/2023
2	MOHAN LAL KUMAWAT S/O SHRI RAMU RAM KUMAWAT NOMINEE OF REC POWER DEVELOPMENT AND CONSULTANCY LIMITED FLAT NO 142 TOWER -1 GC EMERALD, RAMPRASTHA GREENS VAISHALI SECTOR-7, GHAZIABAD-201010, UTTAR PRADESH, OCCUPATION-SERVICE	07682898	NEW DELHI		05/09/2023
3	PUTHIYARKATTU SHIVARAMAN HARIHARAN S/ O SHRI PUTHIYARAKAT VELAYUDHAN SIVARAMAN NOMINEE OF REC POWER DEVELOPMENT AND CONSULTANCY LIMITED FLAT NO.104, SADAR APARTMENT, MAYUR	08657652	NEW DELHI		05/09/2023

	VIHAR EXTENTION, PHASE-1, PLOT NO.9, NEW DELHI-110091, OCCUPATION-SERVICE				
4	SAHAB NARAIN S/O HARI NARAIN NOMINEE OF REC POWER DEVELOPMENT AND CONSULTANCY LIMITED R/O A-1, FLAT NO 103, SOAMI NAGAR, MALVIYA NAGAR, DELHI-110017, OCCUPATION-SERVICE	03641879	NEW DELHI		05/09/2023
5	ARVIND KUMAR S/O NAND KISHOR SINGH NOMINEE OF REC POWER DEVELOPMENT AND CONSULTANCY LIMITED R/O T4-8A, SAI VATIKA APARTMENT, SECTOR-63, FARIDABAD - 121004, OCCUPATION-SERVICE	AHHPK0531C	NEW DELHI		05/09/2023
6	THANGARAJAN BOSH S/O SHRI SITHAN THANGARAJAN NOMINEE OF REC POWER DEVELOPMENT AND CONSULTANCY LIMITED R/O APARTMENT NO S-2, MIDDLE PORTION 2-B, JANGPURA, MATHURA ROAD, NEW DELHI-110014, OCCUPATION-SERVICE	02772316	NEW DELHI		05/09/2023
7	ALOK SINGH S/O JAGDHARI SINGH NOMINEE OF REC POWER DEVELOPMENT AND CONSULTANCY LIMITED R/O MF-23, ELDECO MANSIONZ, SECTOR-48, SOHNA ROAD, GURUGRAM - 122018, OCCUPATION-SERVICE	07498786	NEW DELHI		05/09/2023

Signed before me

Name Prefix (ACA/FCA/ACS/ FCS/ACMA/ FCMA)	*Name of the witness	*Address, Description and Occupation	*DIN / PAN / Passport number / Membership		DSC	Dated
FCA	VINAY KUMAR	1803, TOWER-9, LA RESIDENTIA, TECH ZONE-4, GREATER NOIDA WEST-201306	402996	NEW DELHI	DIN8##402996	05/09/2023

ANNEXURE P/3



सत्यमेव जयते
भारत सरकार

Government of India
विद्युत मंत्रालय

Ministry of Power
केंद्रीय विद्युत प्राधिकरण

Central Electricity Authority

विद्युत प्रणाली योजना एवं मूल्यांकन प्रभाग- II

Power System Planning & Appraisal Division-II

सेवा में/To

As per list of Addresses

विषय : ट्रांसमिशन पर राष्ट्रीय समिति (एनसीटी) की चौदहवीं बैठक का कार्यवृत्त - के सम्बन्ध में ।

Subject: Minutes of the 14th Meeting of National Committee on Transmission (NCT) – regarding.

महोदया (Madam) / महोदय (Sir),

The 14th meeting of the "National Committee on Transmission" (NCT) was held on 09th June, 2023. Minutes of the meeting are enclosed herewith.

भवदीय/Yours faithfully,

(ईशान शरण / Ishan Sharan)

मुख्य अभियंता एवं सदस्य सचिव, एनसीटी
/Chief Engineer & Member Secretary (NCT)

प्रतिलिपि / Copy to:

Joint Secretary (Trans), Ministry of Power, New Delhi

List of Addressees:

1.	Chairperson, Central Electricity Authority Sewa Bhawan, R.K. Puram, New Delhi – 110 066.	2.	Member (Power System), Central Electricity Authority Sewa Bhawan, R.K. Puram, New Delhi – 110 066.
3.	Member (Economic & Commercial), Central Electricity Authority Sewa Bhawan, R.K. Puram, New Delhi – 110 066.	4.	Director (Trans), Ministry of Power Shram Shakti Bhawan, New Delhi-110001.
5.	Sh. Ajay Yadav, Joint Secretary Room no 403, Atal Akshay Urja Bhawan, Opposite CGO Complex gate no 2, Lodhi Road, New Delhi – 110003	6.	Chief Operating Officer, CTUIL, Saudamini, Plot No. 2, Sector-29, Gurgaon – 122 001.
7.	Sh. Rajnath Ram, Adviser (Energy), NITI Aayog, Parliament Street, New Delhi – 110 001.	8.	CMD, Grid Controller of India, B-9, Qutub, Institutional Area, Katwaria Sarai, New Delhi – 110010
9.	Dr. Radheshyam Saha, Ex. Chief Engineer, Central Electricity Authority	10	Ms. Seema Gupta, Ex. Director (Operations), POWERGRID

Special Invitee

Chief Engineer (PCD), CEA

Index

1	Confirmation of the minutes of the 13 th meeting of National Committee on Transmission.....	4
2	Status of the transmission schemes noted/approved/recommended to MoP in the 13 th meeting of NCT:.....	4
3	New Transmission Schemes:.....	4
4	Modification in the earlier approved/notified transmission schemes:.....	43
5	Comprehensive presentation by CTU apprising NCT of measures taken for ensuring development of an efficient, co-ordinated and economical ISTS for smooth flow of electricity.....	49
6	Five-year rolling plan for ISTS capacity addition.....	49
7	Any other issues, with permission of chair.....	49
	Summary of the deliberations of the 14th meeting of NCT held on 09th June, 2023.....	50
	Annex-I.....	71

Minutes of the 14th meeting of National Committee on Transmission

List of Participants is enclosed at Annex-I.

1 Confirmation of the minutes of the 13th meeting of National Committee on Transmission.

1.1 The minutes of the 13th meeting of NCT held on 12.05.2023 were issued vide CEA letter no CEA-PS-12-13/3/2019-PSPA-II dated 19.05.2023. Comments/observations were not received on the minutes.

1.2 Accordingly, members confirmed the minutes.

2 Status of the transmission schemes noted/approved/recommended to MoP in the 13th meeting of NCT:

2.1 The status of the transmission schemes noted/approved/recommended in the 13th meeting of NCT is tabulated below:

Sl. No.	Name of the Transmission Scheme	Noted/ Recommended / Approved	Survey Agency	MoP approval	Remarks
1.	Establishment of State-of the Art Unified Network Management System (U-NMS) for ISTS and State Utility Communication System for Southern Region	Approved	Not Applicable	Not Applicable (Cost of the scheme being less than Rs. 500 Crore)	Under RTM route
2.	Eastern Region Expansion Scheme-XXXVII (ERES-XXXVII)	Approved	Not Applicable	Not Applicable (Cost of the scheme being less than Rs. 500 Crore)	Under RTM route

3 New Transmission Schemes:

3.1 Augmentation of transformation capacity by 1x1500 MVA, 765/400 kV ICT (3rd) at Maheshwaram (PG) substation in Telangana

3.1.1 As per SRLDC, augmentation of transformation capacity at Maheshwaram by 1x1500 MVA, 765/400 kV ICT is required as existing ICTs (2x1500 MVA) at Maheshwaram (GIS) are over loaded and 'N-1' criterion is not getting satisfied. Additionally, as per the studies carried out as part of the Rolling Plan exercise for the year 2026-27, under N-1 contingency of one ICT, loading on the other is around 114% of the rating and therefore augmentation by 1x1500 MVA, 765/400 kV ICT (3rd) at Maheshwaram is required.

Accordingly, augmentation of transformation capacity at Maheshwaram (PG) by 1x1500 MVA (3rd) for improving reliability and meeting the peak demand of Telangana was discussed and agreed in the 14th CMETS-SR meeting held on 26.12.2022.

3.1.2 After detailed deliberations, augmentation of transformation capacity by 1x1500 MVA (3rd), 765/400 kV ICT at Maheshwaram (PG) substation in Telangana was agreed to be implemented under RTM route by POWERGRID.

3.1.3 Summary of the scheme is given below:

Sl. No.	Name of the scheme and implementation timeframe	Estimated Cost (₹ Crores)	Remarks
1.	Augmentation of transformation capacity by 1x1500 MVA, 765/400 kV ICT (3 rd) at Maheshwaram (PG) substation in Telangana Implementation timeframe: 21 months from the date of allocation	123.12	Approved to be implemented under RTM route by POWERGRID.

3.1.4 Detailed scope of the scheme is given below:

Sl. No.	Scope of the Transmission Scheme	Capacity / Route length
1.	Augmentation by 1x1500 MVA, 765/400 kV ICT at Maheshwaram(PG) S/s	<ul style="list-style-type: none"> • 765/400 kV, 1500 MVA ICT – 1 No. • 765 kV ICT bays – 1 No. (GIS) • 400 kV ICT bays – 1 No. (GIS) • 400 kV GIS duct along with associated support structure – 710 m (total length for three phases) • 765 kV GIS duct along with associated support structure – 800 m (total length for three phases)

3.2 Transmission System for Evacuation of Power from potential renewable energy zone in Khavda area of Gujarat under Phase-IV (7 GW)

3.2.1 Transmission system for evacuation of 15 GW power from Khavda RE Park has already been evolved in 3 phases (Phase-I: 3 GW, Phase-II: 5 GW & Phase-III: 7 GW). Phase I and Phase II transmission schemes are under construction and Phase III transmission scheme is under bidding.

3.2.2 Stage-II connectivity applications for 18.605 GW (KPS-I: 9 GW, KPS-II: 3.755 GW & KPS-III: 5.85 GW) have already been received till January, 2023. Considering the rapid pace of connectivity applications being received in Khavda area and request from GPCL vide e-mail dated 23.12.2022 to consider 30 GW RE potential in Khavda for planning the power evacuation system, transmission system for balance 15 GW Khavda REZ has now been planned in two phases (Phase-IV: 7 GW AC & Phase-V: 8 GW HVDC). The present scheme has been planned to enable the evacuation of additional 7 GW RE power from Khavda RE park under Phase IV.

3.2.3 Member Secretary, NCT, stated that the modified scheme as per deliberations in 12th NCT meeting held on 28.03.2023 and meetings held on 20.04.2023 & 09.05.2023 amongst CEA, CTUIL & GRID-INDIA, had been sent by CTUIL to WRPC vide letter dated 12.05.2023 for views/observations within 10 days. However, no views were received from WRPC in this regard.

3.2.4 After detailed deliberations, the transmission scheme was agreed to be implemented subject to views of WRPC. Subsequently, in the 47th WRPC meeting held on 15.06.2023, the subject scheme was deliberated. However, minutes of WRPC meeting are yet to be issued. Details of the packages formulated for implementation of the scheme is given below:

Sl. No.	Name of the scheme	Implementation mode
1.	Part A	TBCB
2.	Part B	TBCB
3.	Part C	TBCB
4.	Part D	TBCB
5.	Part E1	RTM
6.	Part E2	TBCB
7.	Part E3	RTM
8.	Part E4	RTM

Package wise details of the scheme are given below:

3.2.5 Phase-IV: Part A - Summary

Sl. No.	Name of the transmission scheme and implementation timeframe	Estimated Cost (₹ Crores)	Remarks
1.	Transmission System for Evacuation of Power from potential renewable energy zone in Khavda RE park of Gujarat under Phase-IV (7 GW): Part A Tentative Implementation timeframe: 24 months from SPV transfer and matching with Parts B, C & D of Khavda Ph-IV (7 GW)	4091	Recommended to be implemented through TBCB route.

3.2.6 Detailed scope of Part A Scheme is given below:

Sl. No.	Scope of the Transmission Scheme	Capacity/ Route length
	Creation of 765 kV bus section-II at KPS3 (GIS) along with 765 kV Bus Sectionaliser & 1x330 MVAR, 765 kV Bus Reactors on Bus Section-II Bus section – II shall be created at 765 kV & 400 kV level both with 3x1500 MVA, 765/400 kV ICTs at Bus Section-II	Bus Section-II at KPS3 765 kV Bus Sectionaliser – 1 set 1500 MVA, 765/400 kV ICT – 3 Nos. 330 MVAR, 765 kV Bus Reactor – 1 No. 765 kV reactor bay – 1 No. 765 kV ICT bays – 3 Nos.
	Creation of 400 kV bus Section-II at KPS3 (GIS) along with 400 kV Bus Sectionaliser & 1x125 MVAR, 420 kV Bus Reactors on Bus Section-II and 3 Nos. 400 kV bays at Bus Section-II for RE interconnection	Bus Section-II at KPS3 400 kV Bus Sectionaliser – 1 set 125 MVAR, 420 kV Bus Reactors – 1 No.

I/28785/2023

56

Sl. No.	Scope of the Transmission Scheme	Capacity/ Route length
		400 kV reactor bay – 1 No. 400 kV ICT bays – 3 Nos. (for ICTs at Sl. 1 above) 400 kV line bays – 3 Nos. (for RE interconnection)
	KPS3 (GIS) – Lakadia (AIS) 765 kV D/C line	Route length: 185 km
	2 Nos. of 765 kV line bays each at KPS3 (GIS) & Lakadia (AIS) for KPS3 (GIS) – Lakadia (AIS) 765 kV D/C line	<ul style="list-style-type: none"> • 765 kV line bays (GIS) – 2 Nos. (at KPS3 end Bus section-II) • 765 kV line bays (AIS) – 2 Nos. (at Lakadia end)
	±300 MVAR STATCOM with 1x125 MVAR MSC, 2x125 MVAR MSR at KPS3 400 kV Bus section-II	<ul style="list-style-type: none"> • ±300 MVAR STATCOM (with 1x125 MVAR MSC, 2x125 MVAR MSR) • 400 kV bay – 1 No.
	KPS1 (GIS)– Bhuj PS 765 kV 2 nd D/C line	<ul style="list-style-type: none"> • Route length: 110 km
	2 Nos. of 765 kV line bays each at KPS1 (GIS) & Bhuj PS for KPS1 (GIS) – Bhuj PS 765 kV D/C line	<ul style="list-style-type: none"> • 765 kV line bays (GIS) – 2 Nos. (at KPS1 end Bus section-II) • 765 kV line bays (AIS) – 2 Nos. (at Bhuj end)
	330 MVAR switchable line reactors at KPS3 end of KPS3 (GIS) – Lakadia 765 kV D/C line (with NGR bypass arrangement)	<ul style="list-style-type: none"> • 330 MVAR, 765 kV switchable line reactor- 2 Nos. • Switching equipment for 765 kV line reactor- 2 Nos. • 1x110 MVAR spare switchable reactor unit at KPS3 (GIS) end

Note:

- i. Bay(s) required for completion of diameter (GIS) in one-and-half breaker scheme, shall also be executed by the TSP.
- ii. TSP of KPS3 shall provide space for work envisaged at Sl. 1, 2, 4, 5 & 8.
- iii. The TSP of the present scheme shall arrange for additional land for installation of STATCOM (with MSC/MSR) as specified at Sl. No. 5 at KPS3 and TSP of KPS3 shall provide space for 1 No. 400 kV bay for termination of STATCOM.
- iv. TSP of KPS1 and Bhuj PS shall provide space for work envisaged at Sl. No. 7.
- v. The TSP of the present scheme shall arrange for additional land adjoining Lakadia S/s for creation of 2 Nos. 765 kV diameter consisting of 1 main bay & 1 Tie bay (for each diameter)

in one-and-half breaker AIS scheme, towards implementation of 2 Nos. 765 kV line bays at Lakadia S/s (at Sl. No. 4) associated with KPS3 – Lakadia 765 kV D/c line and the same shall be extendable in future for integration of 2nd main bay (future line with switchable line reactor) for diameter completion.

- vi. The line lengths mentioned above are approximate as the exact length shall be obtained after the detailed survey.
- vii. The implementation timeline mentioned above is tentative. Final Timeline would be indicated in the RfP Document.

3.2.7 Phase-IV: Part B - Summary

Sl. No.	Name of the scheme and implementation timeframe	Estimated Cost (₹ Crores)	Remarks
1.	<p>Transmission System for Evacuation of power from potential renewable energy zone in Khavda area of Gujarat under Phase-IV (7 GW): Part B</p> <p>Tentative Implementation timeframe: 24 months from SPV transfer and matching with Parts A, C & D of Khavda Ph-IV (7 GW)</p>	4,766	Recommended to be implemented through TBCB route.

3.2.8 Detailed scope of Part B Scheme is given below:

Sl. No.	Scope of the Transmission Scheme	Capacity/ Route length
1	<p>Establishment of 2x1500 MVA, 765/400 kV & 2x500 MVA, 400/220 kV GIS S/s at a suitable location South of Olpad (between Olpad and Ichhapore) with 2x330 MVAR, 765 kV & 1x125 MVAR, 420 kV bus reactors</p> <p>Future Provisions:</p> <p>Space for</p> <ul style="list-style-type: none"> ➤ 765/400 kV ICT along with bays- 4 Nos. ➤ 765 kV line bays along with switchable line reactors – 8 Nos. ➤ 765 kV Bus Reactor along with bay: 	<p>765/400 kV, 1x1500 MVA ICT-2 Nos. (7x500 MVA single phase units including one spare unit)</p> <p>400/220 kV, 500 MVA ICT – 2 Nos.</p> <p>765 kV ICT bays- 2 Nos.</p> <p>400 kV ICT bays- 4 Nos.</p> <p>220 kV ICT bays- 2 Nos.</p> <p>220 kV BC bay – 1 No.</p> <p>330 MVAR, 765 kV bus</p>

	<p>2 Nos.</p> <ul style="list-style-type: none"> ➤ 765 kV Sectionaliser bay: 1 - set ➤ 400 kV line bays along with switchable line reactor – 8 Nos. ➤ 400/220 kV ICT along with bays - 8 Nos. ➤ 420 kV Bus Reactor along with bay: 3 Nos. ➤ 400 kV Sectionalization bay: 1- set ➤ 220 kV line bays: 18 Nos. ➤ 220 kV Sectionalization bay: 1 set ➤ 220 kV BC: 1 Nos. ➤ Establishment of 2500 MW, \pm 500 kV South Olpad (HVDC) [VSC] terminal station (2x1250 MW) 	<p>reactor-2 Nos.</p> <p>125 MVAR, 420 kV bus reactor-1 No.</p> <p>765 kV reactor bay- 2 Nos.</p> <p>765 kV line bay- 4 Nos.</p> <p>400 kV reactor bay- 1 No.</p> <p>400 kV line bay- 4 Nos.</p> <p>110 MVAR, 765 kV, 1-ph reactor (spare unit for line/bus reactor)-1 No.</p>
2	Vadodara (GIS) –South Olpad (GIS) 765 kV D/C line	Route length: 140 km
3	240 MVAR switchable line reactors on each ckt at Vadodara(GIS) end of Vadodara(GIS) –South Olpad (GIS) 765 kV D/C line (with NGR bypass arrangement)	<ul style="list-style-type: none"> • 240 MVAR, 765 kV switchable line reactor- 2 Nos. • Switching equipment for 765 kV line reactor- 2 Nos. • 1x80 MVAR spare bus reactor available at Vadodara (GIS) to be used as spare
4	2 Nos. of 765 kV line bays at Vadodara (GIS) for Vadodara(GIS) – South Olpad (GIS) 765 kV D/C line	<ul style="list-style-type: none"> • 765 kV line bays (GIS) – 2 Nos. (at Vadodara end)
5	LILO of Gandhar – Hazira 400 kV D/c line at South Olpad (GIS) using twin HTLS conductor with minimum capacity of 1700 MVA per ckt at nominal voltage	LILO route length ~ 10 km.
6	Ahmedabad – South Olpad (GIS) 765 kV D/c line	Route length: 250 km
7	240 MVAR switchable line reactors on each ckt at Ahmedabad & South Olpad (GIS) end of Ahmedabad – South Olpad (GIS) 765 kV D/c line (with NGR bypass arrangement)	<ul style="list-style-type: none"> • 240 MVAR, 765 kV switchable line reactor- 4 Nos. [2 for Ahmedabad end and 2 for South Olpad (GIS) end] • Switching equipment for 765 kV line reactor- 4 Nos. [2 for Ahmedabad end and 2 for South Olpad (GIS) end] • 1x80 MVAR, 765 kV 1-ph spare line reactor – 1 No. (for South Olpad end)

		<ul style="list-style-type: none"> 1x80 MVAR, 765 kV 1-ph spare line reactor being implemented for Lakadia – Ahmedabad line (under Khavda Ph-II Part B scheme) at Ahmedabad S/s to be used as spare
8	2 Nos. of 765 kV line bays at Ahmedabad S/s for Ahmedabad – South Olpad (GIS) 765 kV D/c line	<ul style="list-style-type: none"> 765 kV line bays (AIS) – 2 Nos. (at Ahmedabad end)

Note:

- TSP of Vadodara S/s shall provide space for work envisaged at Sl. No. 3 & 4 given above
- TSP of Ahmedabad S/s shall provide space for work envisaged at Sl. No. 7 & 8 given above
- The line lengths mentioned above are approximate as the exact length shall be obtained after the detailed survey.
- The implementation timeline mentioned above is tentative. Final Timeline would be indicated in the RfP Document.

3.2.9 Phase-IV: Part C - Summary

Sl. No.	Name of the scheme and implementation timeframe	Estimated Cost (₹ Crores)	Remarks
1.	<p>Transmission System for Evacuation of power from potential renewable energy zone in Khavda area of Gujarat under Phase-IV (7 GW): Part C</p> <p>Tentative Implementation timeframe: 24 months from SPV transfer and matching with Parts A, B & D of Khavda Ph-IV (7 GW)</p>	5,340	Recommended to be implemented through TBCB route.

3.2.10 Detailed scope of Part C Scheme is given below:

S l o o	Scope of the Transmission Scheme	Capacity / Route length
1	Establishment of 4x1500 MVA, 765/400 kV & 2x500 MVA, 400/220 kV Boisar-II (GIS) S/s with 2x330 MVAR, 765 kV bus reactors and 2x125 MVAR, 420 kV bus	765/400 kV, 1500 MVA ICT- 4 Nos. (13x500 MVA single phase units)

S I N O	Scope of the Transmission Scheme	Capacity / Route length
	<p>reactors.</p> <p>(2x1500 MVA, 765/400 kV ICTs shall be on each 400 kV section and 2x500 MVA, 400/220 kV ICTs shall be on 400 kV Bus Section-II. 2x125 MVAR Bus reactors shall be such that one bus reactor is placed on each 400 kV bus section. 400 kV Bus Sectionaliser to be kept under normally OPEN condition)</p> <p>Future Provisions:</p> <p>Space for</p> <ul style="list-style-type: none"> ➤ 765/400 kV ICT along with bays- 2 No. ➤ 765 kV line bays along with switchable line reactors – 8 Nos. ➤ 765 kV Bus Reactor along with bay: 2 No. ➤ 765 kV Sectionaliser bay: 1 - set ➤ 400 kV line bays along with switchable line reactor – 8 Nos. ➤ 400/220 kV ICT along with bays - 6 Nos. ➤ 420 kV Bus Reactor along with bay: 2 No. ➤ 220 kV line bays: 12 Nos. ➤ 220 kV Sectionalization bay: 1 set ➤ 220 kV BC: 1 No. 	<p>including one spare unit)</p> <p>400/220 kV, 500 MVA ICT – 2 Nos.</p> <p>765 kV ICT bays- 4 Nos.</p> <p>400 kV ICT bays- 6 Nos. (2 Nos. on Bus Section-I and 4 Nos. on Bus Section-II)</p> <p>400 kV Bus Sectionaliser-1 set</p> <p>220 kV ICT bays- 2 Nos.</p> <p>220 kV BC bay – 1 No.</p> <p>330 MVAR, 765 kV bus reactor-2 Nos.</p> <p>125 MVAR, 420 kV bus reactor-2 Nos.</p> <p>765 kV reactor bays- 2 Nos.</p> <p>765 kV line bays- 6 Nos.</p> <p>400 kV reactor bays- 2 Nos. (one on each bus section)</p> <p>400 kV line bay- 6 Nos. (4 Nos. on bus Section-I and 2 Nos. on bus Section-II)</p>

I/28785/2023

61

S I N O	Scope of the Transmission Scheme	Capacity / Route length
		110 MVAR, 765 kV, 1-ph reactor (spare unit for line/bus reactor)-1 No.
	South Olpad (GIS) – Boisar-II (GIS) 765 kV D/c line	Route length: 225 km
	2 Nos. of 765 kV line bays at South Olpad (GIS) for termination of South Olpad (GIS) – Boisar-II (GIS) 765 kV D/c line	765 kV line bays (GIS) – 2 Nos. (for South Olpad end)
	240 MVAR switchable line reactors on each ckt at South Olpad (GIS) & Boisar-II (GIS) end of South Olpad (GIS) – Boisar-II (GIS) 765 kV D/c line (with NGR bypass arrangement)	<ul style="list-style-type: none"> • 240 MVAR, 765 kV switchable line reactor- 4 [2 for Boisar-II (GIS) and 2 for South Olpad (GIS)] • Switching equipment for 765 kV line reactor- 4 (2 for Boisar-II (GIS) and 2 for South Olpad (GIS)) • 1x80 MVAR, 765 kV 1-ph spare line reactor – 1 No. (for Boisar-II end) • 1x80 MVAR, 765 kV 1-ph spare line reactor proposed for Ahmedabad – South Olpad (GIS) 765 kV line (under Khavda Ph-IV Part B scheme) at South Olpad (GIS) S/s to be used as spare
	LILO of Navsari (New) – Padghe (PG) 765 kV D/c line at Boisar-II	LILO route length: 25 km.
	Boisar-II (Sec-II) – Velgaon (MH) 400 kV D/c (Quad ACSR/AAAC/AL59 moose equivalent) line	Route length: 10 km.
	2 Nos. of 400 kV line bays at Velgaon (MH) for termination of Boisar-II – Velgaon (MH) 400 kV D/c (Quad ACSR/AAAC/AL59 moose equivalent) line	400 kV line bays (GIS) – 2 Nos. [for Velgaon (MH) end]
	LILO of Babhaleswar – Padghe (M) 400 kV D/c line at Boisar-II (Sec-I) using twin HTLS conductor with a minimum capacity of 1700 MVA per ckt at	LILO route length: 65 km.

S l o o	Scope of the Transmission Scheme	Capacity / Route length
	nominal voltage	
	80 MVAR switchable line reactors at Boisar-II end of Boisar-II – Babhaleswar 400 kV D/c line (with NGR bypass arrangement) formed after above LILO	• 80 MVAR, 420 kV switchable line reactor including switching equipment- 2 Nos.
	±200 MVAR STATCOM with 2x125 MVAR MSC, 1x125 MVAR MSR at 400 kV bus section-I of Boisar-II and ±200 MVAR STATCOM with 2x125 MVAR MSC, 1x125 MVAR MSR at 400 kV bus section-II of Boisar-II	<ul style="list-style-type: none"> • ±200 MVAR STATCOM (with MSC/MSR) on 400 kV Section-I • 400 kV bay – 1 No. on Section-I • ±200 MVAR STATCOM (with MSC/MSR) on 400 kV section-II • 400 kV bay – 1 No. on Section-II
	± 300 MVAR STATCOM with 3x125 MVAR MSC, 1x125 MVAR MSR at 400 kV level of Navsari (New)(PG) S/s with 1 No. of 400 kV bay (GIS)	<ul style="list-style-type: none"> • ±300 MVAR STATCOM (with MSC/MSR) • 400 kV bay – 1 No.

Note:

- i. Bay(s) required for completion of diameter (GIS) in one-and-half breaker scheme shall also be executed by the TSP.
- ii. MSETCL shall carry out reconductoring of the balance portion of Padghe (M) – Boisar-II 400 kV D/c line (i.e. from LILO point upto Padghe(M)) and shall also carry out corresponding upgradation of 400 kV bays at Padghe (M) as may be required in matching time-frame of the LILO line. MSETCL has confirmed the maximum capacity of the line which can be achieved after reconductoring considering clearances in existing towers of Babhaleswar – Padghe (M) 400 kV D/c line as 1700 MVA per ckt.
- iii. MSETCL shall implement the LILO of both circuits of Boisar-II – Velgaon 220 kV D/c line at Boisar-II (ISTS) S/s along with 4 Nos. 220 kV GIS bays at Boisar-II in matching time-frame of Boisar-II (ISTS) S/s.
- iv. TSP of South Olpad (GIS) S/s shall provide space for work envisaged at Sl. No. 3 & 4.
- v. MSETCL shall provide space for the work envisaged at Sl. No. 7 at Velgaon S/s.
- vi. TSP of the subject scheme shall implement Inter-tripping scheme on South Olpad (GIS) – Boisar-II (GIS) 765 kV D/c line (for tripping of the switchable line reactor at either end along with the main line breaker).
- vii. The line lengths mentioned above are approximate as the exact length shall be obtained after the detailed survey.
- viii. The implementation timeline mentioned above is tentative. Final Timeline would be indicated in the RfP Document.

3.2.11 Phase-IV: Part D - Summary

Sl. No.	Name of the scheme and implementation timeframe	Estimated Cost (₹ Crores)	Remarks
1.	<p>Transmission System for Evacuation of Power from potential renewable energy zone in Khavda area of Gujarat under Phase-IV (7 GW): Part D</p> <p>Tentative Implementation timeframe: 24 months from SPV transfer and matching with Parts A, B & C of Khavda Ph-IV (7 GW)</p>	3,455	Recommended to be implemented under TBCB route.

3.2.12 Detailed scope of Part D Scheme is given below:

S l o o	Scope of the Transmission Scheme	Capacity/ Route length
1	<p>Establishment of 2x1500 MVA, 765/400 kV & 3x500 MVA, 400/220 kV Pune-III (GIS) S/s with 2x330 MVAR, 765 kV bus reactor and 2x125 MVAR, 420 kV bus reactor.</p> <p>Future Provisions:</p> <p>Space for</p> <ul style="list-style-type: none"> ➤ 765/400 kV ICT along with bays- 4 No. ➤ 765 kV line bays along with switchable line reactors – 8 Nos. ➤ 765 kV Bus Reactor along with bay: 2 No. ➤ 765 kV Sectionalizer bay: 1 -set ➤ 400 kV line bays along with switchable line reactor – 12 Nos. ➤ 400/220 kV ICT along with bays -5 Nos. ➤ 400 kV Bus Reactor along with bay: 2 No. ➤ 400 kV Sectionalization bay: 1 set ➤ 220 kV line bays: 12 Nos. ➤ 220 kV Sectionalization bay: 1 set ➤ 220 kV BC: 1 No. 	<p>765/400 kV, 1500 MVA ICT-2 Nos. (7x500 MVA including one spare unit)</p> <p>400/220 kV, 500 MVA ICT – 3 Nos.</p> <p>765 kV ICT bays- 2 Nos.</p> <p>400 kV ICT bays- 5 Nos.</p> <p>220 kV ICT bays- 3 Nos.</p> <p>220 kV BC bay – 1 No.</p> <p>330 MVAR, 765 kV bus reactor-2 Nos.</p> <p>125 MVAR, 420 kV bus reactor-2 Nos.</p> <p>765 kV reactor bay- 2 Nos.</p>

S I N O	Scope of the Transmission Scheme	Capacity/ Route length
	<ul style="list-style-type: none"> ➤ STATCOM (± 300 MVAR) along with MSC (3x125 MVAR) & MSR (1x125 MVAR): alongwith 1 No. 400 kV bay: 1 No. ➤ 80 MVAR, 765 kV, 1-ph reactor (spare unit for line reactor)-1 No. 	<p>765 kV line bay- 6 Nos.</p> <p>400 kV reactor bay- 2 Nos.</p> <p>400 kV line bay- 2 Nos.</p> <p>110 MVAR, 765 kV, 1-ph reactor (spare unit for line/ bus reactor)-1 No.</p>
	Boisar-II – Pune-III 765 kV D/c line	Route length: 200 km
	330 MVAR switchable line reactors at Pune-III end of Boisar-II – Pune-III 765 kV D/c line (with NGR bypass arrangement).	<ul style="list-style-type: none"> • 330 MVAR, 765 kV switchable line reactor- 2 Nos. • Switching equipment for 765 kV line reactor- 2 Nos. • 1x110 MVAR spare bus reactor available at Pune-III (GIS) to be used as spare
	42 Nos. of 765 kV line bays at Boisar-II for termination of Boisar-II – Pune-III 765 kV D/c line	<ul style="list-style-type: none"> • 765 kV line bays (GIS) – 2 Nos. (for Boisar-II end)
	LILO of Narendra (New) – Pune (GIS) 765 kV D/c line at Pune-III	LILO route length: 10 km.
	330 MVAR switchable line reactors at Pune-III end of Narendra (New) – Pune-III(GIS) 765 kV D/c line (with NGR bypass arrangement).	<ul style="list-style-type: none"> • 330 MVAR, 765 kV switchable line reactor- 2. • Switching equipment for 765 kV line reactor- 2 • 1x110 MVAR spare bus reactor (1-ph) available at Pune-III (GIS) to be used as spare
	LILO of Hinjewadi-Koyna 400 kV S/c line at Pune-III (GIS) S/s	LILO route length: 40 km.
	80 MVAR, 420 kV switchable Line Reactors on each ckt at Pune-III (GIS) end of Pune-III (GIS) – Koyna 400 kV line formed after above LILO (with	<ul style="list-style-type: none"> • 80 MVAR, 420 kV switchable line reactor along with switching equipment- 2 Nos.

S I N O	Scope of the Transmission Scheme	Capacity/ Route length
	NGR bypass arrangement).	

Note:

- i. Bay(s) required for completion of diameter (GIS) in one-and-half breaker scheme, shall also be executed by the TSP.
- ii. Logic for Inter-tripping scheme for tripping of the 330 MVAR switchable line reactor along with main line breaker at Pune (GIS) end of Pune (GIS) – Narendra (New) 765 kV D/c line shall be implemented by the owner of the line after LILO of Narendra (New) – Pune (GIS) 765 kV D/c line at Pune-III
- iii. MSETCL shall implement the following 220 kV lines along with 5 Nos. 220 kV GIS bays at Pune-III (GIS) S/s in matching time-frame of Pune-III S/s:
 - a. LILO of both circuits of Jejuri-Phursungi 220 kV D/c line at Pune-III S/s with HTLS conductor (twin zebra equivalent) along with reconductoring of balance line section viz. LILO point to Phursungi and LILO points to Jejuri with HTLS conductor (twin zebra equivalent)
 - b. Nanded City - Pune PG III 220 kV S/c line with HTLS conductor (twin zebra equivalent)
- iv. TSP of Boisar-II S/s shall provide space for work envisaged at Sl. No. 4.
- v. The line lengths mentioned above are approximate as the exact length shall be obtained after the detailed survey.
- vi. The implementation timeline mentioned above is tentative. Final Timeline would be indicated in the RfP Document.

3.2.13 Phase-IV: Part E1 - Summary

Sl. No.	Name of the scheme and implementation timeframe	Estimated Cost (₹ Crores)	Remarks
1.	Transmission System for Evacuation of Power from potential renewable energy zone in Khavda area of Gujarat under Phase-IV (7 GW): Part E1 Implementation timeframe: 24 months from the date of allocation	216	Approved to be implemented under RTM by Adani Transmission Limited (the TSP implementing KPS 1)

3.2.14 Detailed scope of Part E1 Scheme is given below:

Sl. No.	Scope of the Transmission Scheme	Capacity/ Route length
1	Augmentation of transformation capacity at KPS1 (GIS) by 1x1500 MVA, 765/400 kV ICT (8 th) on bus section-I	1500 MVA, 765/400 kV ICT – 1 No. 765 kV bays – 2 Nos. on bus Section-I (including 1 No. bay for Dia completion) 400 kV bays – 2 Nos. on bus section-I (including 1 No. bay for Dia completion)

Note:

- i. The TSP shall implement one complete diameter consisting of 2 main bays & 1 Tie bay at both 765 kV & 400 kV levels of KPS1 (GIS) for completion of diameter (GIS) in one-and-half breaker scheme.
- ii. Further, TSP of KPS1 shall provide space to carry out the above augmentation work.

3.2.15 Phase-IV: Part E2 - Summary

Sl. No.	Name of the scheme and implementation timeframe	Estimated Cost (₹ Crores)	Remarks
1.	Transmission System for Evacuation of Power from potential renewable energy zone in Khavda area of Gujarat under Phase-IV (7 GW): Part E2 Tentative Implementation timeframe: 21 months from SPV transfer	697	Recommended to be implemented under TBCB route.

3.2.16 Detailed scope of Part E2 Scheme is given below:

S I N O	Scope of the Transmission Scheme	Capacity/ Route length
	Augmentation of transformation capacity at KPS2 (GIS) by 2x1500 MVA, 765/400 kV ICT on Bus section-I (5 th & 6 th) & 2x1500 MVA, 765/400 kV ICT on Bus section-II (7 th & 8 th) & 2 Nos. 400 kV bays at Bus Section-I for RE interconnection and 3 Nos. 400 kV bays at Bus Section-II for RE interconnection	1500 MVA, 765/400 kV ICT – 4 Nos. 765 kV bays – 4 Nos. [2 Nos. complete Dia for 2 ICTs (one on each bus section) and balance 2 ICTs to be terminated in spare bays (one on each section)] 400 kV bays– 10 Nos. [4 Nos. ICT bays (2 on each section) & 5 Nos. line bays (2 on bus section-I & 3 on bus section-II) along with 1 No. bay on Bus Section-II for Dia completion]

Note:

- i. The TSP shall implement two complete diameters (1 on Bus Section-I & 1 on bus section-II) at 765 kV level of KPS2 (GIS) consisting of 2 Main Bays & 1 Tie Bay required for completion of diameter (GIS) in one-and-half breaker scheme.
- ii. The TSP shall implement five complete diameters (2 on Bus Section-I & 3 on Bus Section-II) at 400 kV level of KPS2 (GIS) consisting of 2 Main Bays & 1 Tie bay required for completion of diameter (GIS) in one-and-half breaker scheme.
- iii. Further, TSP of KPS2 shall provide space to carry out the above augmentation work.
- iv. 2 Nos. 400 kV bays at Bus Section-I for RE interconnection and 1 No. 400 kV bays at Bus Section-II for RE interconnection are already under implementation at KPS2.
- v. The implementation timeline mentioned above is tentative. Final Timeline would be indicated in the RfP Document.

3.2.17 Phase-IV: Part E3 - Summary

Sl. No.	Name of the scheme and implementation timeframe	Estimated Cost (₹ Crores)	Remarks
1.	Transmission System for Evacuation of Power from potential renewable energy zone in Khavda area of Gujarat under Phase-IV (7 GW): Part E3	216	Approved to be implemented under RTM by the TSP implementing KPS 3.

	Implementation timeframe: 24 months from date of allocation		
--	---	--	--

3.2.18 Detailed scope of Part E3 Scheme is given below:

No.	Scope of the Transmission Scheme	Capacity/ Route length
	Augmentation of transformation capacity at KPS3 (GIS) by 1x1500 MVA, 765/400 kV ICT (7 th) on Bus section-I	1500 MVA, 765/400 kV ICT – 1 No. 765 kV bays – 2 Nos. on Bus Section-I (including 1 No. bay for Dia completion) 400 kV bays – 2 Nos. on Bus section-I (including 1 No. bay for Dia completion)

Note:

1. The TSP shall implement one complete diameter consisting of 2 Main Bays & 1 Tie Bay at both 765 kV & 400 kV levels of KPS3 (GIS) required for completion of diameter (GIS) in one-and-half breaker scheme.
2. Further, TSP of KPS3 shall provide space to carry out above augmentation work.

3.2.19 Phase-IV: Part E4 - Summary

Sl. No.	Name of the scheme and implementation timeframe	Estimated Cost (₹ Crores)	Remarks
1.	Transmission System for Evacuation of Power from potential renewable energy zone in Khavda area of Gujarat under Phase-IV (7 GW): Part E4 Implementation timeframe: 24 months from date of allocation	235	Approved to be implemented under RTM route by POWERGRID

3.2.20 Detailed scope of Part E4 Scheme is given below:

Sl. No.	Scope of the Transmission Scheme	Capacity/ Route length
1.	Augmentation of transformation capacity at Padghe (PG) (GIS) by 1x1500 MVA,	1500 MVA, 765/400 kV ICT – 1

Sl. No.	Scope of the Transmission Scheme	Capacity/ Route length
	765/400 kV ICT (4 th)	No. 765 kV bays – 2 Nos. (including 1 No. bay for Dia completion) 400 kV bays – 2 Nos. (including 1 No. bay for Dia completion) 765 kV GIB Duct (single phase) – 510 m (approx.) for three phases 400 kV GIB Duct (single phase) – 500 m (approx.) for three phases

Note:

- i. POWERGRID shall implement one complete diameter consisting of 2 main bays & 1 Tie bay at both at 765 kV & 400 kV levels Padghe (PG)(GIS) required for completion of diameter (GIS) in one-and-half breaker scheme.

3.3 Transmission System for Evacuation of Power from potential renewable energy zone in Khavda area of Gujarat under Phase-V (8 GW)

3.3.1 The Phase V (HVDC) transmission scheme has been planned for evacuation of additional 8 GW RE power from Khavda RE park.

3.3.2 Member Secretary, NCT, stated that the modified scheme as per deliberations in 12th NCT meeting held on 28.03.2023 and meetings held on 20.04.2023 & 09.05.2023 amongst CEA, CTUIL & GRID-INDIA had been by CTUIL to WRPC vide letter dated 12.05.2023 for views/observations within 10 days. However, no views were received from WRPC in this regard.

3.3.3 After detailed deliberations, the following was agreed w.r.t. the transmission schemes, subject to views/observations of WRPC. Subsequently, in the 47th WRPC meeting held on 15.06.2023, the subject scheme was deliberated. Minutes of WRPC meeting is to be issued.

Sl. No.	Name of the scheme	Mode of implementation
1.	Part A	TBCB

2.	Part A1	RTM
3.	Part B	To be reviewed.
4.	Part C	TBCB

3.3.4 Phase-V: Part A- Summary

Sl. No.	Name of the scheme and implementation timeframe	Estimated Cost (₹ Crores)	Remarks
1.	Transmission System for Evacuation of Power from potential renewable energy zone in Khavda area of Gujarat under Phase-V (8 GW): Part A Tentative Implementation timeframe: 48 months for Bipole-1 (2x1500 MW) and 54 months for Bipole-2 (2x1500 MW)	24,819	Recommended to be implemented through TBCB route.

3.3.5 Detailed scope of Part A Scheme is given below:

Sl. No.	Scope	Capacity/ Route length
1.	Establishment of 6000 MW, ± 800 kV KPS2 (HVDC) [LCC] terminal station (4x1500 MW) along with associated interconnections with 400 kV HVAC Switchyard*.	6000 MW, ± 800 kV KPS2 (HVDC) [LCC] Terminal station
2.	Establishment of 6000 MW, ± 800 kV Nagpur (HVDC) [LCC] terminal station (4x1500 MW) along with associated interconnections with 400 kV HVAC Switchyard*	6000 MW, ± 800 kV Nagpur (HVDC) [LCC] terminal station
3.	±800 kV HVDC Bipole line (Hexa lapwing) between KPS2 (HVDC) and Nagpur (HVDC) (1200 km) (with Dedicated Metallic Return) (capable to evacuate 6000 MW with overload as specified)	Route length: 1200 km.
4.	Establishment of 6x1500 MVA, 765/400 kV ICTs at Nagpur-S/s along with 2x330 MVAR (765 kV) & 2x125 MVAR, 420 kV bus reactors along with associated interconnections with HVDC Switchyard*. The 400 kV bus shall be established in 2 sections through 1 set of 400 kV bus sectionaliser so that 3x1500 MVA ICTs are placed in each section. The bus sectionaliser shall be normally closed and may be opened based on Grid	<ul style="list-style-type: none"> ○ 765/400 kV, 1500 MVA ICT-6 (3 on each 400 kV section) (19 single phase units including one spare unit) ○ 765 kV ICT bays- 6 Nos. ○ 400 kV ICT bays- 6 Nos. (3 on each section) ○ 330 MVAR 765 kV bus reactor-2 Nos. ○ 125 MVAR 420 kV bus

Sl. No.	Scope	Capacity/ Route length
	<p>requirement.</p> <p>Future Provisions at Nagpur:</p> <p>Space for:</p> <ul style="list-style-type: none"> ○ 765/400 kV, 1500 MVA ICT- 4 (1 on 400 kV bus section-II & 3 on future 400 kV bus section-III) ○ 765 kV line bays along with switchable line reactors – 10 Nos. ○ 765 kV Bus Reactor along with bay: 2 No. ○ 765 kV Sectionalizer bay: 1 -set ○ 400 kV line bays along with switchable line reactor – 12 Nos. ○ 400 kV Bus sectionaliser- 1 Set ○ 400/220 kV ICT along with bays -9 Nos. (3 Nos. on 400 kV bus sections II & 6 Nos. on future bus section-III) ○ 400 kV Bus Reactor along with bay: 4 No. (1 each on 400 kV bus sections I & II and 2 on future 400 kV bus section-III) ○ 220 kV line bays: 16 Nos. ○ 220 kV Sectionalization bay: 2 set ○ 220 kV BC & TBC: 3 Nos. ○ 80 MVAR, 765 kV, 1-ph reactor (spare unit for line reactor)-1 	<p>reactor-2 Nos. (one on each section)</p> <ul style="list-style-type: none"> ○ 765 kV reactor bay- 2 Nos. ○ 765 kV line bay- 4 Nos. ○ 400 kV reactor bay- 2 Nos. (one on each section) ○ 400 kV Bus sectionaliser - 1 Set ○ 110 MVAR, 765 kV, 1-ph reactor (spare unit for line/bus reactor) - 1 No.
5.	LILO of Wardha – Raipur 765 kV one D/c line (out of 2xD/c lines) at Nagpur	LILO route length: 30 km.
6.	Installation of 240 MVAR switchable line reactor at Nagpur end on each ckt of Nagpur – Raipur 765 kV D/c line	<ul style="list-style-type: none"> ● 240 MVAR, 765 kV switchable line reactors- 2 Nos. (at Nagpur end) ● Switching equipment for 765 kV line reactor- 2 Nos. (at Nagpur end) ● 80 MVAR, 765 kV, 1-ph reactor (spare unit for line reactor)-1 No.

* The 400 kV interconnections (along with all associated equipment/ bus extension, etc.) between HVDC & HVAC switchyards shall be implemented by the TSP

Note:

- i. The 2x1500 MW poles shall emanate from 400 kV bus section 1 of KPS2 and terminate at bus section 1 of Nagpur. Similarly, the other 2x1500 MW poles shall emanate from 400 kV bus section 2 of KPS2 and terminate at bus section 2 of Nagpur.

- ii. HVDC System will be designed considering 100% power reversal capability. The rated power transmission capacity as well as the rated transmission voltage shall be defined and guaranteed at the rectifier end of the AC yard.
- iii. TSP of KPS2 shall provide space for the establishment of the HVDC system as per above scope.
- iv. The line lengths mentioned above are approximate as the exact length shall be obtained after the detailed survey.
- v. The implementation timeline mentioned above is tentative. Final Timeline would be indicated in the RfP Document.

3.3.6 Phase-V: Part A1- Summary

Sl. No.	Name of the scheme and implementation timeframe	Estimated Cost (₹ Crores)	Remarks
1.	Transmission System for Evacuation of Power from potential renewable energy zone in Khavda area of Gujarat under Phase-V (8 GW): Part A1 Implementation timeframe: Matching with implementation of Khavda Phase-V Part A scheme viz. Bipole-1 (2x1500 MW) ± 800 kV Nagpur (HVDC) [LCC] which is 48 months from SPV transfer.	21	Approved to be implemented under RTM by POWERGRID i.e. owner of Wardha S/s.

3.3.7 Detailed scope of Part A1 is given below:

Sl. No.	Scope	Capacity/ Route length
1.	Conversion of 330 MVAR Fixed LR at Wardha (on each ckt of Wardha – Raipur 765 kV D/c line being LILOed at Nagpur) into Bus Reactors at Wardha S/s	765 kV reactor bays- 2 Nos. & Conversion of 330 MVAR Fixed LR at Wardha (on each ckt of Wardha – Raipur 765 kV D/c line being LILOed at Nagpur) into Bus Reactors through creation of 2 new diameters and shifting of Reactors

Note:

- i. POWERGRID shall implement two new diameters consisting of 1 main bay & 1 Tie bay at 765 kV level of Wardha S/s required in one-and-half breaker AIS scheme for termination of 2 Nos. of 330 MVAR Bus reactors & the same shall be extended in future for integration of 2nd main bay (future line with switchable line reactor) for diameter completion.

3.3.8 **Phase-V: Part B:** Augmentation of transformation capacity at KPS2 (GIS) by 1x1500 MVA, 765/400 kV ICT on Bus Section I (9th) and at KPS 3 (GIS) by 1x1500 MVA, 765/400 kV ICT on Bus Section-II (8th)

It was deliberated that the above ICTs would be required in the matching timeframe of VSC based HVDC (Part C) and hence would be reviewed and taken up subsequently.

3.3.9 CTUIL had proposed ± 525 kV VSC based HVDC system. It was deliberated that ± 500 kV HVDC systems are already existing in the country and tested tower design for ± 500 kV systems are already available. In order to reduce the time involved in engineering and testing, it was opined that already proven design of ± 500 kV may be adopted in this case also. Hence, the rating of HVDC system was revised to ± 500 kV, 2500 MW.

3.3.10 Summary of Phase-V: Part C scheme is given below:

Sl. No.	Name of the scheme and implementation timeframe	Estimated Cost (₹ Crores)	Remarks
1.	Transmission System for Evacuation of Power from potential renewable energy zone in Khavda area of Gujarat under Phase-V (8 GW): Part C Tentative Implementation timeframe: 48 months from SPV transfer	12,000	Recommended to be implemented through TBCB route.

3.3.11 Detailed scope of Part C is given below:

Sl. No.	Scope	Capacity/ Route length
1.	Establishment of 2500 MW, ± 500 kV KPS3 (HVDC) [VSC] terminal station (2x1250 MW) at a suitable location near KPS3 substation with associated interconnections with 400 kV HVAC Switchyard*	2500 MW, ± 500 kV KPS3 (HVDC) [VSC] Terminal station
2.	Establishment of 2500 MW, ± 500 kV South Olpad (HVDC) [VSC] terminal station (2x1250 MW) along with associated interconnections with 400 kV HVAC Switchyard of South Olpad S/s*	2500 MW, ± 500 kV South Olpad (HVDC) [VSC] terminal station
3.	Establishment of KPS3 (HVDC) S/s along with 2x125 MVAR, 420 kV bus reactors along with associated interconnections with HVDC Switchyard*. The 400 kV bus shall be established in 2 sections through 1 set of 400 kV bus sectionaliser to be kept normally OPEN. 400/33 kV, 2x50 MVA transformers for	<ul style="list-style-type: none"> ○ 400/33 kV, 1x50 MVA ICT along with bays- 2 Nos. ○ 125 MVAR 420 kV bus reactor-2 Nos. (one on each section) ○ 400 kV reactor bay- 2 Nos. (one on each section)

Sl. No.	Scope	Capacity/ Route length
	<p>exclusively supplying auxiliary power to HVDC terminal. MVAR</p> <p>Future Provisions at KPS3 (HVDC) S/s</p> <p>Space for:</p> <ul style="list-style-type: none"> ○ 400 kV line bays – 6 Nos. (3 on each section) ○ 400 kV reactor bay- 2 Nos. (one on each section) 	<ul style="list-style-type: none"> ○ 400 kV Bus sectionaliser- 1 Set
4.	KPS3 – KPS3 (HVDC) 400 kV 2xD/c (Quad ACSR/AAAC/AL59 moose equivalent) line along with the line bays at both substations	<p>Route length- 2 km</p> <p>400 kV GIS line bays - 4 Nos. at KPS3 (2 Nos. on each bus section)</p> <p>400 kV GIS line bays - 4 Nos at KPS3 (HVDC) (2 Nos. on each bus section)</p>
5.	±500 kV HVDC Bipole line between KPS3 (HVDC) and South Olpad (HVDC) (with Dedicated Metallic Return) (capable to evacuate 2500 MW)	Route length: 600 km

* The 400 kV interconnections (along with all associated equipment/ bus extension, etc.) between HVDC & HVAC switchyards shall be implemented by the TSP

Note:

- i. The 1250 MW pole-1 shall emanate from 400 kV bus section 1 of KPS3 (HVDC) and terminate at South Olpad S/s. Similarly, the 1250 MW pole-2 shall emanate from 400 kV bus section 2 of KPS3 (HVDC) and terminate at South Olpad S/s.
- ii. HVDC System will be designed with 100% power reversal capability as well as black start, automatic grid restoration & dynamic reactive power support capability.
- iii. The rated power transmission capacity as well as the rated transmission voltage shall be defined and guaranteed at the rectifier end of the AC yard.
- iv. TSP of KPS3 shall provide space for scope at Sl. No. 4 as per the above scope
- v. TSP of South Olpad S/s shall provide space for scope at Sl. No. 2 as per above scope
- vi. The line lengths mentioned above are approximate as the exact length shall be obtained after the detailed survey.
- vii. The implementation timeline mentioned above is tentative. Final Timeline would be indicated in the RfP Document.

3.4 400 kV Western Region Network Expansion scheme in Kallam area of Maharashtra

3.4.1 Transmission System for evacuation of power from RE Projects in Osmanabad area (1 GW) in Maharashtra is presently under implementation by Kallam Transmission Ltd. (expected by Oct'23). Further, augmentation of transformation capacity at Kallam PS by 2x500 MVA, 400/220 kV ICTs (3rd& 4th) along with 220 kV bays for RE interconnection is also under implementation which shall enable injection of additional 1 GW at 220 kV level of Kallam PS.

Additional connectivity has also been granted to M/s Torrent at 400 kV level (1 No. bay) and hence there is a cumulative requirement of evacuation of about 3.25 GW (2 GW at 220 kV level and 1.25 GW at 400 kV level) from Kallam PS. The subject Transmission system shall enable evacuation of upto 3.25 GW power from Kallam PS.

3.4.2 CTUIL stated that generally a minimum implementation schedule of 24 months is specified for transmission schemes. However, as a special case, considering the small length of LILO line and no visible forest/wildlife involvement, reduced implementation time-frame of 18 months may be specified in this case in order to match the commissioning of transmission scheme and associated RE generation.

3.4.3 After detailed deliberations, it was decided that the transmission scheme Western Region Network Expansion scheme in Kallam area of Maharashtra, will be implemented under TBCB route with an implementation timeframe of 18 months.

3.4.4 Summary of the scheme is as given below:

Sl. No.	Name of the scheme and implementation timeframe	Estimated Cost (₹ Crores)	Remarks
1.	Western Region Network Expansion scheme in Kallam area of Maharashtra. Tentative Implementation timeframe: 18 months from SPV transfer	160	Approved to be implemented through TBCB route.

3.4.5 Detailed scope of the scheme is given below:

Scope of the Transmission Scheme	Capacity/ Route length
LILO of both circuits of Parli(M) – Karjat(M)/Lonikand-II (M) 400 kV D/c	LILO route length~ 15 km.

	line (twin moose) at Kallam PS	
	4 Nos. 400 kV line bays at Kallam PS for LILO of both circuits of Parli(M) – Karjat(M)/Lonikand-II(M) 400 kV D/c line (twin moose) at Kallam PS	400 kV line bays (AIS) – 4 Nos. (for Kallam PS end)
	63 MVAR, 420 kV switchable line reactor (with NGR bypassing arrangement) on each ckt at Kallam PS end of Karjat – Kallam 400 kV D/c line (~140km.)	63 MVAR, 420 kV switchable line reactor including Switching equipment - 2 Nos. (at Kallam end)

Note:

- i. TSP of Kallam PS (Kallam Transmission Ltd.) shall provide requisite space at Kallam PS for above scope of work
- ii. The 50 MVAR fixed line reactor on each ckt at Parli (M) end of Kallam – Parli (M) 400 kV D/c line shall be converted into switchable (with NGR bypass arrangement & provision of inter-tripping scheme to trip the line reactors along with the main line breakers) by MSETCL in matching time-frame of the above scheme. MSETCL vide email dated 08.06.2023 has informed that conversion of fixed 50 MVAR line reactor at 400 kV Parli (M) (Girwali) end into switchable reactor is feasible.
- iii. The line lengths mentioned above are approximate as the exact length shall be obtained after the detailed survey.
- iv. The implementation timeline mentioned above is tentative. Final Timeline would be indicated in the RfP Document.

3.5 Transmission system for evacuation of power from Rajasthan REZ Ph-IV (Part-2: 5.5 GW) (Jaisalmer/Barmer Complex)

- 3.5.1 The transmission scheme was earlier proposed for evacuation of about 7.5 GW power from Jaisalmer/Barmer Complex. The scheme was deliberated in the 12th NCT meeting held on 24.03.23. In the meeting, various issues like system strength (SCR), requirement of Barmer-I PS as well as high angular separation in the proposed 765 kV Jalore-Mandsaur D/C (length 320 kms) inter-regional transmission line were raised. Subsequently, various joint study meetings were held for review and phasing of transmission scheme among CEA, CTUIL and GRID-INDIA and revised studies were carried out.
- 3.5.2 Accordingly, revised studies were carried out incorporating the increased electricity demand of Rajasthan as suggested by Grid-India, and it was observed that the transmission system was adequate for evacuation of about 5.5 GW RE power (solar) in summer & winter scenario.
- 3.5.3 The modified transmission scheme was discussed and agreed in the 65th NRPC meeting held on 21.04.23. The scheme was further agreed in the 46th WRPC meeting held on 03.02.23.
- 3.5.4 Further, transmission scheme for evacuation of power from Neemuch/Mandsaur 2 GW WEZ was proposed as transmission system in Western Region whereas creation of Mandsaur 765 kV S/s was envisaged as a part of Rajasthan REZ Ph-IV (Part-2) Scheme. As deliberated in the 12th NCT meeting, it was decided to combine the transmission scheme for Neemuch/Mandsaur with Rajasthan Ph-IV Part- C Scheme which involves the creation of 765 kV Mandsaur S/s.
- 3.5.5 GRID-INDIA requested to review the reactive compensation of Sirohi PS - Rishabdeo 765 kV D/c line (170 km) and Rishabdeo - Mandsaur 765 kV D/c (160 km) line as reactive compensation seemed to be on the higher side. CTUIL stated that with the proposed line length reactive compensation on Sirohi PS- Rishabdeo 765 kV D/c line is about 73% and Rishabdeo-Mandsaur 765 kV D/c is about 78%. CTUIL also mentioned that in view of high voltages in night off-peak scenario specially for RE evacuation lines, reactive compensation is to be kept adequate to address reactive management issues, however, it was observed that the reactive compensation on Rishabdeo-Mandsaur 765 kV D/c line is about 78% which has some scope for reduction. Grid-India stated that if possible, reactive compensation of Rishabdeo-Mandsaur 765 kV D/c line may be reduced. Hence, it was decided that 330 MVAR line reactor at Rishabdeo end on above line may be replaced with 240 MVAR reactor.

3.5.6 After detailed deliberations, the following was decided w.r.t. the transmission schemes:

Sl. No.	Scheme	Remarks
1.	Part A	TBCB
2.	Part B	TBCB

3.	Part C	Scheme of 2 GW Neemuch / Mandsaur to be merged with Part C. Combined scheme to be implemented under TBCB.
4.	Part D	TBCB
5.	Part E	TBCB
6.	Part F1	Part F1 and F2 to be combined.
7.	Part F2	Combined scheme (Part F i.e. Part F1+F2) to be implemented under TBCB.
8.	Part G	Deferred. To be taken up based on GIB clearance of dedicated transmission line associated with RE generation at Fatehgarh-II PS along with GIB clearance of Fatehgarh-II PS- Bhadla-III PS 400 kV D/C line
9.	Part H1	TBCB
10.	Part H2	RTM

3.5.7 Part A: Summary

Sl. No.	Name of the scheme and implementation timeframe	Estimated Cost (₹ Crores)	Remarks
1.	Transmission system for evacuation of power from Rajasthan REZ Ph-IV (Part-2: 5.5 GW) (Jaisalmer/Barmer Complex): Part A Tentative Implementation timeframe: 24 months from SPV transfer	2,206	Recommended to be implemented through TBCB route.

3.5.8 Detailed scope of Part A scheme is given below:

Sl. No.	Scope of the Transmission Scheme	Capacity/ Route length
1	Establishment of 4x1500 MVA, 765/400 kV & 5x500 MVA, 400/220 kV Fatehgarh-IV (Section-2) Pooling Station along with 2x240 MVAR (765 kV) Bus Reactor & 2x125 MVAR (420 kV) Bus Reactor [Future space provisions already approved at Fatehgarh-IV in 8 th NCT meeting dated 25.03.22 would be utilized for the present scheme]	<ul style="list-style-type: none"> • 765/400 kV, 1500 MVA ICT- 4 Nos. (13x500 MVA including one spare unit) • 765 kV ICT bays- 4 Nos. • 240 MVAR, 765 kV Bus Reactor- 2 Nos. (7x80 MVAR including one spare unit) • 765 kV Bus reactor bays-2 Nos. • 765 kV line bays - 4 Nos. [for LILO of Fatehgarh-III - Beawer 765 kV D/c (2nd) line at Fatehgarh-IV (Section-2) PS] • 400/220 kV, 500 MVA ICT -5 Nos. • 400 kV ICT bays- 9 Nos. • 400 kV line bays - 2 Nos. [For Fatehgarh-IV (Sec-2) - Bhinmal (PG) D/c line] • 125 MVAR, 420 kV Bus Reactor-2 Nos. • 400 kV Bus reactor bays- 2 Nos.

I/28785/2023

Sl. No.	Scope of the Transmission Scheme	Capacity/ Route length
		<ul style="list-style-type: none"> • 400 kV Sectionalisation bay: 1 set • 220 kV ICT bays- 5 Nos. • 220 kV line bays: 6 Nos. (for RE connectivity) • 220 kV BC (2 Nos.) and 220 kV TBC (2 Nos.) • 220 kV Sectionalisation bay: 1 set
2	Fatehgarh-IV (Section-2) PS – Bhinmal (PG) 400 kV D/c line (Twin HTLS) along with 50 MVAR switchable line reactor on each ckt at each end	Route Length: 200 km <ul style="list-style-type: none"> • 50 MVAR, 420 kV switchable line reactors at Fatehgarh-IV (Section-2) PS – 2 Nos. • 50 MVAR, 420 kV, switchable line reactors at Bhinmal (PG) – 2 Nos. • Switching equipment for 420 kV, 50 MVAR switchable line reactors at Fatehgarh-IV (Section-2) PS – 2 Nos. • Switching equipment for 420 kV, 50 MVAR switchable line reactors at Bhinmal (PG) – 2 Nos.
3	LILO of both ckts of 765 kV Fatehgarh-III- Beawar D/c line (2nd) at Fatehgarh-IV (Section-2) PS along with 330 MVAR switchable line reactor at Fatehgarh-IV PS end of each ckt of 765 kV Fatehgarh-IV-Beawar D/c line (formed after LILO)	LILO length: 15 km <ul style="list-style-type: none"> • 330 MVAR, 765 kV switchable line reactors at Fatehgarh-IV (Section-2) PS – 2 Nos. • Switching equipment for 330 MVAR, 765 kV switchable line reactors at Fatehgarh-IV (Section-2) PS – 2 Nos. • 110 MVAR (765 kV) spare reactor single phase unit at Fatehgarh-IV (Section-2) PS end – 1 No.
4	2 Nos. of 400 kV line bays at Bhinmal (PG)	400 kV line bays - 2 Nos.

Note:

- i. Transmission system for evacuation of about 2 GW RE power from REZ in Rajasthan (20 GW) under Phase-III Part A1 at Fatehgarh-IV (Section-1) is under bidding.
- ii. Transmission system under Phase-IV (Part 2) is for evacuating 4-5 GW RE potential at Fatehgarh-IV (Section 2), which is utilising the future provision (approved in 8th NCT meeting dated 25.03.22) at Fatehgarh-IV approved under Phase-III scheme.
- iii. The line lengths mentioned above are approximate as the exact length shall be obtained after the detailed survey
- iv. POWERGRID to provide space for 2 Nos. of 400 kV line bays at Bhinmal (PG) along with the space for switchable line reactors without any cost implications.
- v. Implementation of A, B, C, D, E, F, H1, H2 packages shall be aligned
- vi. Switchable line reactors to be implemented with NGR bypass arrangement.
- vii. The implementation timeline mentioned above is tentative. Final Timeline would be indicated in the RfP Document.

3.5.9 Part B: Summary

Sl. No.	Name of the scheme and implementation timeframe	Estimated Cost (₹ Crores)	Remarks
1.	Transmission system for evacuation of power from Rajasthan REZ Ph-IV (Part-2: 5.5 GW) (Jaisalmer/Barmer Complex): Part B Tentative Implementation timeframe: 24 months from SPV transfer	3,279	Recommended to be implemented through TBCB route.

3.5.10 Detailed scope of Part B scheme is given below:

Sl. No.	Scope of the Transmission Scheme	Capacity/ Route length
1	Establishment of 2x1500 MVA, 765/400 kV Substation at suitable location near Sirohi along with 2x240 MVAR (765 kV) & 2x125 MVAR (420 kV) Bus Reactor Future provisions: Space for <ul style="list-style-type: none"> • 765/400 kV ICT along with bays- 4 Nos. • 765 kV line bays along with switchable line reactors – 10 Nos. • 765 kV Bus Reactor along with bay: 1 Nos. • 400 kV line bays along with switchable line reactor –4 Nos. • 400 kV line bays –4 Nos. • 400 kV Bus Reactor along with bay: 1 No. • 400 kV Sectionalization bay: 2 sets • 400/220 kV ICT along with bay - 6 Nos. • 220 kV line bays -10 Nos. • 220 kV Sectionalization bay: 2 sets • 220 kV BC (3 Nos.) & TBC (3 Nos.) • STATCOM (2x±300 MVAR) along with MSC (4x125 MVAR) & MSR (2x125 MVAR) along with two number 400 kV bays. 	<ul style="list-style-type: none"> • 765/400 kV, 1500 MVA ICT- 2 Nos. (7x500 MVA including one spare unit) • 765 kV ICT bays-2 Nos. • 240 MVAR, 765 kV Bus Reactor-2 Nos. (7x80 MVAR including one spare unit) • 765 kV Bus reactor bays-2 Nos. • 765 kV line bays- 2 Nos. [for D/c line to Fatehgarh-IV (Section-2) PS] • 400 kV ICT bays- 2 Nos. • 400 kV line bays - 2 Nos. [for D/c line to Chittorgarh (PG) S/s] • 125 MVAR, 420 kV Bus Reactor-2 Nos. • 400 kV Bus reactor bays- 2 Nos.
2	Fatehgarh-IV (Section-2) PS – Sirohi PS 765 kV D/c line along with 240 MVAR switchable line reactor for each circuit at each end	Route Length – 240 km <ul style="list-style-type: none"> • 765 kV, 240 MVAR switchable line reactors at Fatehgarh-IV (Section-2) PS – 2 Nos. • 765 kV, 240 MVAR switchable line reactors

Sl. No.	Scope of the Transmission Scheme	Capacity/ Route length
		at Sirohi PS– 2 Nos. <ul style="list-style-type: none"> Switching equipment for 765 kV, 240 MVAR switchable line reactors at Fatehgarh-IV (Section-2) PS – 2 Nos. Switching equipment for 765 kV, 240 MVAR switchable line reactors at Sirohi PS – 2 Nos.
3	Sirohi PS-Chittorgarh (PG) 400 kV D/c line (Quad) along with 80 MVAR switchable line reactor for each circuit at Sirohi PS end	Route Length ~160 km <ul style="list-style-type: none"> 420 kV, 80 MVAR switchable line reactors at Sirohi PS – 2 Nos. Switching equipment for 420 kV, 80 MVAR switchable line reactors at Sirohi PS – 2 Nos.
4	2 No. of 400 kV line bays at Chittorgarh (PG) S/s	400 kV line bays at Chittorgarh (PG) S/s - 2 Nos.
5	2 No. of 765 kV line bays at Fatehgarh-IV (Section-2) PS	765 kV line bays at Fatehgarh-IV (Section-2) PS – 2 Nos.

Note:

- The line lengths mentioned above are approximate as the exact length shall be obtained after the detailed survey.
- POWERGRID to provide space for 2 Nos. of 400 kV line bays at Chittorgarh (PG).
- Developer of Fatehgarh-IV S/s (Section-2) to provide space for 2 Nos. of 765 kV line bays at Fatehgarh-IV(Section-2) PS along with the space for switchable line reactor
- Implementation of A, B, C, D, E, F, H1, H2 packages shall be aligned
- Switchable line reactors to be implemented with NGR bypass arrangement.
- The implementation timeline mentioned above is tentative. Final Timeline would be indicated in the RfP Document.

3.5.11 **Part C: Summary**

Sl. No.	Name of the scheme and implementation timeframe	Estimated Cost (₹ Crores)	Remarks
1.	Transmission system for evacuation of power from Rajasthan REZ Ph-IV (Part-2: 5.5 GW) (Jaisalmer/Barmer Complex): Part C Tentative Implementation timeframe: 24 months from SPV transfer	2,708	Recommended to be implemented through TBCB route.

3.5.12 Detailed scope of Part C scheme is given:

S l o o	Scope of the Transmission Scheme	Capacity/ Route length
	<p>Establishment of 3x1500 MVA, 765/400 kV & 5x500 MVA, 400/220 kV Mandsaur Pooling Station along with 2x330 MVAR (765 kV) Bus Reactors & 2x125 MVAR, 420 kV Bus Reactor</p> <p>Future Provisions:</p> <p>Space for:</p> <ul style="list-style-type: none"> • 765/400 kV ICT along with bays- 3 No. • 765 kV line bays along with switchable line reactors – 12 Nos. • 765 kV Bus Reactor along with bay: 2 No. • 765 kV Sectionalizer bay: 1 -set • 400 kV line bays along with switchable line reactor – 12 Nos. • 400/220 kV ICT along with bays -5 Nos. • 400 kV Bus Reactor along with bay: 2 No. • 400 kV Sectionalization bay: 1- set • 220 kV line bays: 11 Nos. • 220 kV Sectionalization bay: 1 set • 220 kV BC and TBC: 1 Nos. • STATCOM (\pm 300 MVAR) along with MSC (2x125 MVAR) & MSR (1x125 MVAR) along with one 400 kV bay. 	<p>765/400 kV, 1500 MVA ICT – 3 Nos. (10x500 MVA single phase units including one spare unit)</p> <p>400/220 kV, 500 MVA ICT – 5 Nos. (3 Nos. on 220 kV bus section-1 & 2 Nos. on 220 kV bus section-2)</p> <p>765 kV ICT bays – 3 Nos.</p> <p>400 kV ICT bays – 8 Nos.</p> <p>330 MVAR 765 kV bus reactor-2 Nos. (7x110 MVAR single phase units including one spare unit)</p> <p>765 kV bus reactor bay- 2 Nos.</p> <p>765 kV line bay- 2 Nos. (for Indore line)</p> <p>80 MVAR, 765 kV, 1-ph reactor (spare unit)-1 No.</p> <p>125 MVAR, 420 kV bus reactor-2 Nos.</p> <p>400 kV reactor bay- 2 Nos.</p> <p>220 kV ICT bays – 5 Nos.</p> <p>220 kV line bays – 7 Nos. (4 Nos. on bus section-1 and 3 Nos. on bus section-2)</p> <p>220 kV Bus Sectionalizer – 1 set</p> <p>220 kV TBC bay – 2 Nos.</p> <p>220 kV BC bay – 2 Nos.</p>
	Mandsaur PS – Indore(PG) 765 kV D/c Line	Route Length ~ 200 km
	3x330 MVAR switchable line reactor (SLR) on each ckt at Mandsaur end of Mandsaur PS – Indore(PG) 765 kV D/c Line	<ul style="list-style-type: none"> • 330 MVAR, 765 kV switchable line reactor- 2 Nos. • Switching equipment for 765 kV line reactor- 2 Nos.
	42 Nos. of 765 kV line bays at Indore(PG) for termination of Mandsaur PS – Indore(PG) 765 kV D/c Line	<ul style="list-style-type: none"> • 765 kV line bays – 2 Nos. (for Indore (PG) end)

Note:

- i. The line lengths mentioned above are approximate as the exact length shall be obtained after detailed survey
- ii. POWERGRID to provide space for 2 Nos. of 765 kV line bays at Indore S/s

- iii. Implementation of A, B, C, D, E, F, H1, H2 packages shall be aligned
- iv. Switchable line reactors to be implemented with NGR bypass arrangement
- v. The implementation timeline mentioned above is tentative. Final Timeline would be indicated in the RfP Document.

3.5.13 Part D: Summary

Sl. No.	Name of the scheme and implementation timeframe	Estimated Cost (₹ Crores)	Remarks
1.	Transmission system for evacuation of power from Rajasthan REZ Ph-IV (Part-2: 5.5 GW) (Jaisalmer/Barmer Complex): Part D Tentative Implementation timeframe: 24 months from SPV transfer	2,227	Recommended to be implemented through TBCB route.

3.5.14 Detailed scope of Part D scheme is given below:

S. No.	Scope of the Transmission Scheme	Capacity/ Route length
1	Beawar- Mandsaur PS 765 kV D/c line along with 240 MVAR switchable line reactor for each circuit at each end	Route Length – 260 km <ul style="list-style-type: none"> • 765 kV, 240 MVAR switchable line reactors at Beawar – 2 Nos. • 765 kV, 240 MVAR switchable line reactors at Mandsaur PS – 2 Nos. • Switching equipment for 765 kV, 240 MVAR switchable line reactors at Beawar – 2 Nos. • Switching equipment for 765 kV, 240 MVAR switchable line reactors at Mandsaur PS – 2 Nos.
2	2 No. of 765 kV line bays each at Beawar S/s & Mandsaur S/s	765 kV line bays - 4 Nos. (2 Nos. each at Beawar S/s and Mandsaur PS)

Note:

- i. The line lengths mentioned above are approximate as the exact length shall be obtained after the detailed survey
- ii. Developer of Mandsaur PS to provide space for 2 Nos. of 765 kV line bays at Mandsaur S/s along with the space for switchable line reactor.
- iii. Developer of Beawar S/s to provide space for 2 Nos. of 765 kV line bays at Beawar S/s along with the space for switchable line reactor.
- iv. Implementation of A, B, C, D, E, F, H1, H2 packages shall be aligned
- v. Switchable line reactors to be implemented with NGR bypass arrangement
- vi. The implementation timeline mentioned above is tentative. Final Timeline would be indicated in the RfP Document.

3.5.15 Part E: Summary

Sl. No.	Name of the scheme and implementation timeframe	Estimated Cost (₹ Crores)	Remarks
1.	Transmission system for evacuation of power from Rajasthan REZ Ph-IV (Part-2 :5.5 GW) (Jaisalmer/Barmer Complex): Part E Tentative Implementation timeframe: 24 months from SPV transfer	3,251	Recommended to be implemented through TBCB route.

3.5.16 Detailed scope of Part E scheme is given below:

Sl. No.	Scope of the Transmission Scheme	Capacity/ Route length
1	Establishment of 765 kV Substation at suitable location near Rishabdeo (Distt. Udaipur) along with 2x240 MVAR (765 kV) Bus Reactor Future Provisions: Space for ➤ 765/400 kV ICT along with bays- 5 No. along with spare unit ➤ 765 kV line bays along with switchable line reactors – 6 Nos. ➤ 765 kV Bus Reactor along with bay: 1 No. ➤ 400 kV line bays along with switchable line reactor – 4 Nos. ➤ 400 kV line bays – 4 Nos. ➤ 400 kV Bus Reactor along with bay: 3 Nos. ➤ 400 kV Sectionalization bay: 2 sets ➤ 400/220 kV ICT along with bay - 6 Nos. ➤ 220 kV line bays -10 Nos. ➤ 220 kV Sectionalization bay: 2 sets ➤ 220 kV BC (3 Nos.) & TBC (3 Nos.) ➤ STATCOM (2 x ±300MVAR) along with MSC (4x125 MVAR) & MSR (2x125 MVAR) along with two number 400 kV bays.	<ul style="list-style-type: none"> • 240 MVAR, 765 kV Bus Reactor- 2 Nos. (7x80 MVAR including one spare unit) • 765 kV Bus reactor bays-2 Nos. • 765 kV line bays - 6 Nos. [for 765 kV Sirohi PS- Rishabdeo – Mandsaur D/c line and LILO of one circuit of 765 kV Chittorgarh-Banaskanta D/c line at Rishabdeo S/ s]
2	Sirohi PS- Rishabdeo 765 kV D/c line along with 330 MVAR switchable line reactor for each circuit at Sirohi end	Route Length – 170 km <ul style="list-style-type: none"> • 765 kV, 330 MVAR switchable line reactors at Sirohi PS– 2 Nos. • Switching equipment for 765 kV, 330 MVAR switchable line reactors at Sirohi PS– 2 Nos. • 110 MVAR (765 kV) spare reactor single phase unit at Sirohi PS – 1 No.
3	Rishabdeo - Mandsaur PS 765 kV D/c line along with 240 MVAR switchable line reactor	Route Length – 160 km

	for each circuit at Rishabdeo end	<ul style="list-style-type: none"> • 765 kV, 240 MVAR switchable line reactors at Rishabdeo – 2 Nos. • Switching equipment for 765 kV, 240 MVAR switchable line reactors at Rishabdeo – 2 Nos.
4	LILO of one circuit of 765 kV Chittorgarh-Banaskanta D/c line at Rishabdeo S/s (20 km)	LILO route length~ 20 km
5	2 No. of 765 kV line bays each at Sirohi PS & Mandsaur S/s	<ul style="list-style-type: none"> • 765 kV line bays – 4 Nos. (2 Nos. each at Sirohi PS & Mandsaur PS)

Note:

- The line lengths mentioned above are approximate as the exact length shall be obtained after the detailed survey
- Developer of Sirohi PS to provide space for 2 Nos. of 765 kV line bays at Sirohi PS along with the space for switchable line reactors, including spare unit.
- Developer of Mandsaur PS to provide space for 2 Nos. of 765 kV line bays at Mandsaur PS.
- Implementation of A, B, C, D, E, F, H1, H2 packages shall be aligned
- Switchable line reactors to be implemented with NGR bypass arrangement.
- The implementation timeline mentioned above is tentative. Final Timeline would be indicated in the RfP Document.

3.5.17 Part F: Summary (by clubbing F1 & F2 Schemes)

Sl. No.	Name of the scheme and implementation timeframe	Estimated Cost (₹ Crores)	Remarks
1.	Transmission system for evacuation of power from Rajasthan REZ Ph-IV (Part-2: 5.5 GW) (Jaisalmer/Barmer Complex): Part F Tentative Implementation timeframe: 24 months from SPV transfer	2,735	Recommended to be implemented through TBCB route.

3.5.18 Detailed scope of Part F scheme is given below:

Sl. No.	Scope of the Transmission Scheme	Capacity/ Route length
1	Establishment of 3x1500 MVA, 765/400 kV & 2x500 MVA, 400/220 kV Barmer-I Pooling Station along with 2x240 MVAR (765 kV) Bus Reactor & 2x125 MVAR (420 kV) Bus Reactor Future provisions: Space for ➤ 765/400 kV ICT along with bays- 3 No. ➤ 765 kV line bays along with switchable	<ul style="list-style-type: none"> • 765/400 kV, 1500 MVA ICT- 3 Nos. (10x500 MVA including one spare unit) • 765 kV ICT bays-3 Nos. • 240 MVAR, 765 kV Bus Reactor-2 Nos. (7x80 MVAR, including one spare unit) • 765 kV Bus reactor bays-2 Nos. • 765 kV line bays- 2 Nos. (for D/c line to Sirohi PS) • 400/220 kV, 500 MVA ICT -2 Nos. • 400 kV ICT bays- 5 Nos.

Sl. No.	Scope of the Transmission Scheme	Capacity/ Route length
	line reactors – 4 Nos. ➤ 765 kV Bus Reactor along with bay: 1 No. ➤ 400 kV line bays –4 ➤ 400 kV line bays along with switchable line reactor –4 Nos. ➤ 400/220 kV ICT along with bays -8 Nos. ➤ 400 kV Bus Reactor along with bay: 1 No. ➤ 400 kV Sectionalization bays: 2 sets ➤ 220 kV line bays for connectivity of RE Applications -10 Nos. ➤ 220 kV Sectionalization bay: 3 sets ➤ 220 kV BC (3 Nos.) & TBC (3 Nos.) ➤ STATCOM (2x±300 MVAR) along with MSC (4x125 MVAR) & MSR (2x125 MVAR) along with two number 400 kV bays	<ul style="list-style-type: none"> • 125 MVAR, 420 kV Bus Reactor-2 Nos. • 400 kV Bus reactor bays- 2 Nos. • 400 kV line bays - 2 Nos. [for D/c line to Fatehgarh-III(Section-2) PS] • 220 kV ICT bays- 2 Nos. • 220 kV line bays: 4 Nos. (for RE connectivity) • 220 kV BC (1 No.) & TBC (1 No.)
2	Fatehgarh-III (Section-2) PS – Barmer-I PS 400 kV D/c line (Quad)	Route Length ~50 km
3	Barmer-I PS– Sirohi PS 765 kV D/c line along with 240 MVAR switchable line reactor for each circuit at each end	Route Length ~ 200 km <ul style="list-style-type: none"> • 765 kV, 240 MVAR switchable line reactors at Barmer-I PS – 2 Nos. • 765 kV, 240 MVAR switchable line reactors at Sirohi PS – 2 Nos. • Switching equipment for 765 kV 240 MVAR switchable line reactors at Barmer-I PS – 2 Nos. • Switching equipment for 765 kV 240 MVAR switchable line reactors at Sirohi PS – 2 Nos.
4	2 No. of 400 kV line bays at Fatehgarh-III (Section-2) PS	400 kV line bays at Fatehgarh-III (Section-2) PS - 2 Nos.
5	2 No. of 765 kV line bays at Sirohi PS	765 kV line bays at Sirohi PS – 2 Nos.

Note:

- i. The line lengths mentioned above are approximate as the exact length shall be obtained after the detailed survey
- ii. Developer of Sirohi PS to provide space for 2 Nos. of 765 kV line bays at Sirohi PS along with the space for switchable line reactor.
- iii. Developer of Fatehgarh-III PS (Section-2) to provide space for 2 Nos. of 400 kV line bays at Fatehgarh-III PS (Section-2).
- iv. Switchable line reactors to be implemented with NGR bypass arrangement
- v. Implementation of A, B, C, D, E, F, H1, H2 packages shall be aligned.

- vi. The implementation timeline mentioned above is tentative. Final Timeline would be indicated in the RfP Document.

3.5.19 Part G: Summary

Sl. No.	Name of the scheme and implementation timeframe	Estimated Cost (₹ Crores)	Remarks
1.	Transmission system for evacuation of power from Rajasthan REZ Ph-IV (Part-2 :5.5 GW) (Jaisalmer/Barmer Complex): Part G Augmentation by 1x1500 MVA, 765/400 kV ICT at Fatehgarh-II PS	132	The scheme was agreed to be deferred and it was decided that the scheme would be taken up for implementation in the matching timeframe of Fatehgarh-II PS- Bhadla 3 PS 400 kV D/c line, once the transmission line is approved by the GIB Committee constituted by Hon'ble Supreme Court Committee.

3.5.20 Part H1: Summary

Sl. No.	Name of the scheme and implementation timeframe	Estimated Cost (₹ Crores)	Remarks
1.	Transmission system for evacuation of power from Rajasthan REZ Ph-IV (Part-2: 5.5 GW) (Jaisalmer/Barmer Complex): Part H1 Tentative Implementation timeframe: 24 months from SPV transfer	3,674	Recommended to be implemented through TBCB route.

3.5.21 Detailed scope of Part H1 scheme is given below:

Scope of the Transmission Scheme	Capacity / line length km
Establishment of 765/400 kV (2x1500 MVA), 400/22 kV (2x500 MVA) & 220/132 kV (3x200 MVA) Kurawar S/s with 2x330 MVAR 765	<ul style="list-style-type: none"> 765/400 kV, 1500 MVA ICT – 2 (7 single units of 500 MVA including one spare unit) 400/220 kV, 500 MVA ICT – 2

I/28785/2023

88

S N o	Scope of the Transmission Scheme	Capacity / line length km
	<p>kV bus reactor and 1x125 MVAR, 420 kV bus reactor.</p> <p>Future Provisions:</p> <p>Space for</p> <ul style="list-style-type: none"> • 765/400 kV ICT along with bays- 4 no. • 765 kV line bays along with switchable line reactors – 8 nos. • 765 kV Bus Reactor along with bay: 2 no. • 765 kV Sectionalizer bay: 1 -set • 400 kV line bays along with switchable line reactor – 8 nos. • 400/220 kV ICT along with bays -6 nos. • 420 kV Bus Reactor along with bay: 3no. • 400 kV Sectionalization bay: 1- set • 220 kV line bays: 12 nos. • 220 kV Sectionalization bay: 1set • 220 kV BC and TBC: 1 no. • 220/132 kV ICT along with bays: 5 Nos. • 132 kV line bays: 16 nos. • 132 kV Sectionalization bay: 1 set • 132 kV TBC– 1 no. • STATCOM (± 300 MVAR) along with MSC (2x125 MVAR) & MSR (1x125 MVAR) along with 400 kV bay. 	<ul style="list-style-type: none"> • 220/132 kV, 200 MVA ICT – 3 • 765 kV ICT bays- 2 • 400 kV ICT bays- 4 • 220 kV ICT bays – 5 • 132 kV ICT bays - 3 • 330 MVAR 765 kV bus reactor-2 • 125 MVAR 420 kV bus reactor-1 • 765 kV reactor bay- 2 • 765 kV line bays- 4 • 400 kV line bays- 4 • 400 kV reactor bay- 1 • 220 kV BC – 1 • 220 kV TBC – 1 • 132 kV TBC – 1 • 110 MVAR, 765 kV, 1-ph reactor (spare unit)-1 • 80 MVAR, 765 kV, 1-ph reactor (spare unit)-1
	Mandsaur – Kurawar 765 kV D/c line	Route length: 235 km
	240 MVAR switchable line reactors on each ckt at both ends of Mandsaur – Kurawar 765 kV D/c line	<ul style="list-style-type: none"> • 240 MVAR, 765 kV switchable line reactor- 4 (2 for Mandsaur end and 2 for Kurawar end) • Switching equipment for 765 kV line reactor- 4 (2 for Mandsaur end and 2 for Kurawar end)
	42 nos. of 765 kV line bays at Mandsaur S/s for termination of Mandsaur – Kurawar 765 kV D/c line	<ul style="list-style-type: none"> • 765 kV line bays – 2 Nos. (for Mandsaur end)
	LILLO of Indore – Bhopal 765 kV S/c line at Kurawar	LILLO route length: 15 km.
	Kurawar – Ashtha 400 kV D/c (Quad	Route length: 65 km

I/28785/2023

89

S N o	Scope of the Transmission Scheme	Capacity / line length km
	ACSR/AAAC/AL59 moose equivalent) line	
	2 nos. of 400 kV line bays at Ashtha (MP) S/s for termination of Kurawar – Ashtha 400 kV D/c line	400 kV line bays – 2 Nos. [for Ashtha (MP) end]
	LILO of one circuit of Indore – Itarsi 400 kV D/c line at Astha	LILO route length: 30 km
	2 nos. of 400 kV line bays at Ashtha (MP) S/s for LILO of one circuit of Indore – Itarsi 400 kV D/c line at Astha	400 kV line bays – 2 Nos. [for Ashtha (MP) end]
	Shujalpur – Kurawar 400 kV D/c (Quad ACSR/AAAC/AL59 moose equivalent) line	Route length: 40 km
	2 nos. of 400 kV line bays at Shujalpur(PG) S/s for termination of Shujalpur – Kurawar 400 kV D/c line	400 kV line bays – 2 Nos. [for Shujalpur (PG) end]

Note:

- i. The line lengths mentioned above are approximate as the exact length shall be obtained after the detailed survey.
- ii. MPPTCL has confirmed availability of space for 2 nos. 400 kV bays at Ashta (MP) S/s and for 2 nos. additional bays, MPPTCL has informed that adjacent land is private land and may be purchased by the project developer at their cost as per requirement.
- iii. Implementation of A,B,C,D, E ,F, H1 & H2 packages shall be aligned
- iv. TSP of the subject scheme shall implement Inter-tripping scheme on Mandsaur – Kurawar 765 kV D/c line (for tripping of the switchable line reactor at Mandsaur/Kurawar end along with the main line breaker).
 - v. Switchable line reactors to be implemented with NGR bypass arrangement
 - vi. Developer of Mandsaur S/s to provide space for 2 Nos. 765 kV line bays for Mandsaur – Kurawar 765 kV D/c line.
 - vii. POWERGRID to provide space for 2 Nos. 400 kV line bays at Shujalpur S/s for Shujalpur – Kurawar 400 kV D/c line.
- viii. The implementation timeline mentioned above is tentative. Final Timeline would be indicated in the RfP Document.

3.5.22 Part H2: Summary

Sl. No.	Name of the scheme and	Estimated Cost	Remarks
---------	------------------------	----------------	---------

	implementation timeframe	(₹ Crores)	
1.	<p>Transmission system for evacuation of power from Rajasthan REZ Ph-IV (Part-2 :5.5 GW) (Jaisalmer/Barmer Complex): Part H2</p> <p>Provision of NGR bypass arrangement and inter tripping scheme on 240 MVAR SW LR at Bhopal end of Kurawar – Bhopal 765 kV S/c line (~60 km.): Part H2</p> <p>Implementation timeframe: In matching timeframe of H1 Scheme</p>	0.45	To be awarded under RTM to BDTCL i.e. the TSP owing the Indore – Bhopal 765 kV S/c line .

3.5.23 Detailed scope of Part H2 scheme is given below:

S l o t	Scope of the Transmission Scheme	Capacity/ Route length
1	Provision of NGR bypass arrangement and inter tripping scheme on 240 MVAR Switchable Line Reactor at Bhopal end of Kurawar – Bhopal 765 kV S/c line (~Route length: 60 km)	NGR bypass arrangement and inter tripping scheme (Bhopal end)

3.6 Requirement of additional FOTE of STM-16 capacity at Bhuj PS to cater to connectivity of RE Gencos.

3.6.1 To connect 6 number of RE generators (Inox, Vadava Desalpar, Narayanpar, Adani Ratadia, Renew Power, Alfancar Energy) directly to existing FOTE at Control Room of Bhuj PS maintaining MSP (1+1) and for making independent connectivity for upcoming generators at this station, Additional STM-16 capacity SDH equipment is required

3.6.2 The “Requirement of additional FOTE of STM-16 capacity at Bhuj PS to cater connectivity of RE Gencos”, has been deliberated in 46th TCC/ WRPC meeting. WRPC concurred the proposal of “Requirement of additional FOTE of STM-16 capacity at Bhuj PS to cater connectivity of RE Gencos” at an estimated cost of Rs 60 Lacs.

3.6.3 After detailed deliberations, the scheme was approved to be implemented under RTM route by POWERGRID.

3.6.4 Summary of the scheme is given below:

Sl. No.	Name of the scheme and implementation timeframe	Estimated Cost (₹ Crores)	Remarks
1.	Requirement of additional FOTE of STM-16 capacity at Bhuj PS to cater to connectivity of RE Gencos Implementation timeframe: 12 months from date of allocation	0.6	Approved to be implemented under RTM route by POWERGRID

3.6.5 Detailed Scope of the Scheme is given below:

Sl. No.	Scope of the Scheme	Estimated Cost
1.	Supply and installation of 01 number 10 MSP (1+1) FOTE or 02 No. 5 MSP (1+1) FOTE (STM-16 capacity) at Bhuj PS.	Rs. 60 Lakhs

3.7 Requirement of additional FOTE of STM-16 capacity at Bhuj-II substation to cater connectivity of RE Gencos.

3.7.1 To connect 6 number of RE generators (Inox, Vadava Desalpar, Narayanpar, Adani Ratadia, Renew Power, Alfancar Energy) directly to existing FOTE at Control Room of Bhuj PS maintaining MSP (1+1) and for making independent connectivity for upcoming generators at this station, Additional STM-16 capacity SDH equipment is required

3.7.2 The “Requirement of additional FOTE of STM-16 capacity at Bhuj II to cater connectivity of RE Gencos”, has been deliberated in 46th TCC/ WRPC meeting. WRPC concurred the proposal of “Requirement of additional FOTE of STM-16 capacity at Bhuj II to cater connectivity of RE Gencos” at estimated cost of Rs 30 Lacs.

3.7.3 After detailed deliberations, the scheme was approved to be implemented under RTM mode by M/s PBTL.

3.7.4 Summary of the scheme is given below:

Sl. No.	Name of the scheme and implementation timeframe	Estimated Cost (₹ Crores)	Remarks
1.	Requirement of additional FOTE of STM-16 capacity at Bhuj-II substation to cater connectivity of RE Gencos Implementation timeframe: 12 months from date of allocation	0.3	Approved to be implemented under RTM mode by M/s PBTL

3.7.5 Detailed Scope of the Scheme is given below:

Sl. No.	Scope of the Scheme	Estimated Cost
1.	Supply and installation of 01 number 5 MSP (1+1) FOTE (STM-16 capacity) at Bhuj-II station.	Rs. 30 Lakhs

3.8 Congestion in ISTS communication link via Dehgam- Ranchhodpura- Santhalpur- Bhachau- Mundra

3.8.1 The communication link via Dehgam-Ranchhodpura-Santhalpur-Bhachau-Mundra was at STM-4 level. Further, this link was extended through Mundra-Bhuj-Santhalpur Repeater-Banaskantha at STM-16 level. The owner of these stations is POWERGRID. This communication network is being used for routing the data Bhuj-PS, Bhuj-II, Lakadia, CGPL Mundra and various RE generators connected to these stations to WRLDC/NLDC. Communication link via Dehgam-Ranchhodpura-Santhalpur repeater-Banaskantha is also used for routing inter regional data between WR-NR.

As on date, the STM-4 level bandwidth on Dehgam-Ranchhodpura-Santhalpur Repeater is almost 100% utilized and on Santhalpur repeater-Bhachau-Mundra is 75% utilized. Outage of these lines affects the telemetry of the entire Bhuj location and CGPL Mundra.

3.8.2 The “Upgradation of STM-4 communication link of Dehgam, Ranchhodpura, Santhalpur Repeater, Bhachau and CGPL Mundra to STM-16 capacity”, has been deliberated in 46th TCC/ WRPC meeting held on 02-03 Feb 2023. WRPC concurred the proposal of “Upgradation of STM-4 communication link of Dehgam, Ranchhodpura, Santhalpur Rep, Bhachau and CGPL Mundra to STM-16 capacity” at estimated cost of Rs 1.5 Cr.

3.8.3 After detailed deliberations, the scheme was approved to be implemented under RTM route by POWERGRID.

3.8.4 Summary of the scheme is given below:

Sl. No.	Name of the scheme and implementation timeframe	Estimated Cost (₹ Crores)	Remarks
1.	Upgradation of STM-4 communication link of Dehgam, Ranchhodpura, Santhalpur Rep, Bhachau and CGPL Mundra to STM-16 capacity. Implementation timeframe: 12 months from date of allocation	1.5	Approved to be implemented under RTM route by POWERGRID

3.8.5 Detailed Scope of the Scheme is given below:

Scope of the Scheme	Estimated Cost
---------------------	----------------

<p>1. Supply and installation of 5 No. STM-16 SDH, 5 MSP (1+1) for all the below mentioned stations-</p> <p>a) Dehgam b) Ranchhodpura c) Santhalpur Repeater d) Bhachau e) CGPL Mundra</p>	<p>Rs. 1.5 Cr.</p>
--	--------------------

3.9 Transmission scheme for evacuation of power from Neemuch/Mandsaur 2 GW WEZ

3.9.1 SECI vide letter dated 23.06.2022 has informed that in order to provide round the clock (RTC) Power (with wind, solar and storage components), they have identified certain locations with high solar and wind potential where work on RE evacuation system may be taken up immediately. 2 GW Wind Potential at Neemuch/Mandsaur is one such prioritized RE Zone.

3.9.2 Accordingly, scheme was evolved to cater to the evacuation of power from Neemuch/Mandsaur 2 GW WEZ and was discussed in the 12th NCT meeting held on 24.03.2023. During the meeting, the establishment of 765 kV Mandsaur Pooling Station [Under Transmission system for Rajasthan REZ Phase-IV Part-2 (5.5 GW)] was agreed to be reviewed and it was decided that the proposal of creation of 400 kV and 220 kV levels at Mandsaur PS (under the subject scheme), would also be reviewed along with 765 the kV Pooling Station at Mandsaur.

3.9.3 After detailed deliberations, it was decided that the scheme shall be merged with Part C of the Transmission system for evacuation of power from Rajasthan REZ Ph-IV (Part-2: 5.5 GW) (Jaisalmer/Barmer Complex) and would be implemented under TBCB route. Please refer para 3.5.

3.10 Change in implementation timeline of STATCOM and HVDC

3.10.1 Siemens and TATA Power had requested to increase the timeline of commissioning of STATCOMs from 24 months to 30 months on account of increased delivery period of Power Electronics, Control Cards, Air Core Reactors, Valve Cooling systems etc. globally e.g. for $\pm 2 \times 300$ MVAR STATCOM at any sub-station, time frame for implementation of STATCOMs to be as given below, in place of 24 months:

- ± 300 MVAR (1st): 24 months
- ± 300 MVAR (2nd): 30 months

3.10.2 After detailed deliberations, it was agreed that the base time shall remain 24 months for 1st STATCOM unit. For further STATCOM units, additional 3 months of time for each unit e.g. 27 months (for 2nd STATCOM unit) will be given.

3.10.3 Chairperson, CEA, stated that the list of components of STATCOM, not being manufactured in India, may be prepared and put up to the Technical Scoping Committee (TSC) Committee under Chairperson, CEA, constituted to inter-alia identify the identify the potential technologies that can be considered for indigenous development in the country, bring out the relevance of the technology for the future power sector. The Committee would in turn make recommendations to the Apex Committee, the High Level Committee under Hon'ble Minister of Power.

3.10.4 Similarly, Hitachi had requested to increase the timeline of commissioning of Bhadla-Fatehpur HVDC from 42 months to 49 months for Bipole I and 54 months for Bipole II, considering the present global uncertainties on supplies of components and their lead time.

After detailed deliberations, it was agreed that the timeline of commissioning of HVDC shall be increased by 06 months for Bipole-II i.e. if implementation timeline is 48 months for Bipole I, it should be 54 months for Bipole-II.

3.10.5 However, the changed timelines for implementation of HVDC & SATCOM schemes would be applicable only to the new schemes brought up in NCT henceforth.

3.10.6 Chairperson, CEA, also stated that rating of HVDC transmission system must be standardised by CEA so that delivery time is reduced.

4 Modification in the earlier approved/notified transmission schemes:

4.1 Transmission system for evacuation of power from Shongtong Karcham HEP (450 MW) and Tidong HEP (150 MW)

4.1.1 A comprehensive transmission scheme (400 kV Jhangi-Wangtoo-Panchkula D/c Corridor) for evacuation of power from two Hydro Electric Projects (HEPs) viz Tidong (150 MW) of Tidong Power Generation Private Limited (STATKRAFT) and Shongtong Karcham HEP (450 MW) of HPPCL in Himachal Pradesh was evolved. The transmission scheme was approved by MoP based on the recommendation by NCT for implementation through TBCB route. Subsequently, HPPCL had intimated that the commissioning date of Shongtong Karcham HEP (STKHEP) had been revised (preponed) from July'26 to July'25 and requested to review the timelines of the transmission system for evacuation of power from Shongtong Karcham HEP (STKHEP) in Himachal Pradesh due to the revised timeline of commissioning of STKHEP.

4.1.2 The revised scheme was also discussed in the 65th NRPC meeting held on 21.04.2023. During the NRPC meeting, MS, NRPC stated that all efforts may be made to reduce the time frame of the interim part to ensure that the generation is not stranded. Therefore, NRPC Forum recommended NCT to give consideration to generation project schedule and accordingly transmission system may be developed.

4.1.3 In the NCT meeting, CTUIL informed that based on the preliminary survey report for 400 kV Wangtoo-Panchkula D/c line, conductor in certain portion of the transmission line may need to be of different configuration (due to very high altitude encountered in certain sections) in order to avoid Corona inception gradient. The cost of the transmission scheme may also increase. Accordingly, CTUIL was requested to confirm change in conductor configuration if any along with revised cost of the scheme based on the survey report and submit the same within two weeks.

4.2 Revised timeframe of the transmission scheme “Transmission system for evacuation of power from Luhri Stage-I HEP”

4.2.1 The transmission system for evacuation of power from Luhri Stage-I HEP was agreed in the 8th meeting of NCT held on 25.03.2022 with the following scope of works:

Sl. No.	Scope of the Transmission Scheme	Capacity/ Route length
1.	Establishment of 7x105 MVA, 400/220 kV Nange GIS Pooling Station along with 125 MVAR (420kV) Bus Reactor at Nange (GIS) PS (1-Ph units along with one spare unit) Future provisions: Space for <ul style="list-style-type: none"> 400/220 kV ICTs (315 MVA with single phase units) along with associated bays: 3 Nos. 400 kV line bays along with switchable line reactor: 3 Nos. 220 kV line bays: 10 nos 	315 MVA, 400/220 kV ICT: 2 Nos. (7x105 MVA including 1 spare ICT) 400 kV ICT bays: 2 Nos. 220 kV ICT bays: 2 Nos. 400 kV, 125 MVAR Bus Reactor-1 No. 400 kV Bus Reactor bay- 1 No. 400 kV Line Bays- 2 Nos.
2.	Nange (GIS) Pooling Station – Koldam 400 kV D/c line (Triple snowbird) (<i>only one circuit is to be terminated at Kol Dam while second circuit would be connected to bypassed circuit of Kol Dam – Ropar/Ludhiana 400 kV D/c line</i>)	Route length: 40 km
3.	1 No. of 400 kV line bay at Koldam S/s for termination of Nange (GIS) Pooling Station – Koldam 400 kV line along with 125 MVAR (420kV) Bus Reactor at Koldam S/s (1-Ph units along with one spare unit)	400 kV Line Bays- 2 Nos. 400 kV, 125 MVAR Bus Reactor-1 No. 400 kV Bus Reactor bay- 1 No.
4.	Bypassing one ckt of Koldam –	

Sl. No.	Scope of the Transmission Scheme	Capacity/ Route length
	Ropar/Ludhiana 400 kV D/c line (Triple snowbird) at Koldam and connecting it with one of the circuit of Nange- Koldam 400 kV D/c line(Triple snowbird), thus forming Nange- Ropar/ Ludhiana one line (Triple snowbird)	
5.	1x50 MVAR switchable line reactor at Ropar end of Nange- Ropar/ Ludhiana 400 kV line	400 kV, 50 MVAR Line Reactor- 1 No. 400 kV Reactor Bay- 1 No.

4.2.2 The above mentioned transmission scheme was notified in Gazette dated 02.06.2022 and RECPDCL was appointed as the BPC of the transmission scheme. The transmission scheme is currently under bidding with the implementation timeframe of 24.04.2025 (in matching timeframe of Luhri Stage-I HEP).

4.2.3 SJVNL vide letter dated 17.02.2023 informed that Luhri Stage-I HEP is likely to be commissioned by August, 2026, hence the time frame of Luhri Stage-I may be considered as 31.08.2026. The same was acknowledged in a meeting convened by CEA on 07.03.2023. Accordingly, it was decided that the timeframe of the transmission scheme “Transmission system for evacuation of power from Luhri Stage-I HEP”, would be revised to 31st August, 2026.

4.2.4 NCT noted the same.

4.3 **Delinking of 400 kV Fatehgarh-II- Bhadla-III D/c line from transmission scheme “Transmission system for evacuation of power from REZ in Rajasthan (20 GW) under Phase-III Part B1”**

4.3.1 The transmission scheme “Transmission system for evacuation of power from REZ in Rajasthan (20 GW) under Phase-III Part B1” was agreed in the 5th meeting of the NCT held on 25.08.2021 and 02.09.2021, with the following scope of works:

- Establishment of 2x1500 MVA 765/400 kV & 3x500 MVA 400/220 kV pooling station at Bhadla-3
- Fatehgarh-2 PS – Bhadla-3 PS 400 kV D/c line
- Bhadla-3 PS – Sikar-II S/s 765 kV D/c line

- 4.3.2 The above mentioned transmission scheme was notified in the Gazette dated 06.12.2022 and PFCCCL was appointed as the BPC of the transmission scheme. As the transmission scheme is falling under core GIB area, PFCCCL approached the Committee formed by Hon'ble Supreme Court for obtaining the necessary GIB clearance.
- 4.3.3 Subsequently, a meeting was held on 01.05.2023 under the chairmanship of Secretary, MoP, to review the progress of under construction/ under bidding/ planned Transmission Projects for evacuation of Renewable Energy (RE) projects, wherein it was highlighted that the GIB clearance for Fatehgarh-2 PS – Bhadla-3 PS 400 kV D/c line has not been received due to which the bidding process for the transmission scheme is getting delayed. Considering that, Secretary, MoP, directed that the process of delinking of 400 kV Fatehgarh-II- Bhadla-III D/c line from Phase-III Part-B1 may be carried out at the earliest and a separate package may be formed comprising 400 kV Fatehgarh-II- Bhadla III D/c line.
- 4.3.4 The same was deliberated in a meeting convened by CEA on 10.05.2023, wherein PFCCCL (BPC) was requested to delink the 400 kV Fatehgarh-II- Bhadla-III D/c line as directed by Secretary, MoP. Further, it was recommended that for timely completion of the bidding process, bidders may be given 4 weeks of time for bid submission by the BPC, since the transmission scheme (Transmission system for evacuation of power from REZ in Rajasthan (20 GW) under Phase-III Part B1) is already under the bidding process for the past few months and also linked with other transmission schemes under Phase-III.
- 4.3.5 In view of above, the modification in the scope of the transmission scheme “Transmission system for evacuation of power from REZ in Rajasthan (20 GW) under Phase-III Part B1” is as follows:

Sl. No.	Existing Scope	Revised Scope
1.	<p>Establishment of 2x1500 MVA 765/400 kV & 3x500 MVA 400/220 kV pooling station at Bhadla-3 along with 2x330 MVAR (765 kV) Bus Reactor & 2x125 MVAR (420kV) Bus Reactor</p> <ul style="list-style-type: none"> • 765/400 kV 1500 MVA ICTs: 2 Nos. (7x500 MVA including one spare unit) • 765 kV ICT bays - 2 Nos. • 400/220 kV, 500 MVA ICT – 3 Nos. • 765 kV line bays -2 Nos. • 400 kV ICT bays – 5 Nos. • 220 kV ICT bays - 3 Nos. • 400 kV line bays - 2 Nos. • 220 kV line bays: 5 Nos. • 330 MVAR Bus Reactor-2 Nos. (7x110 MVAR, including one spare unit) 	<p>Establishment of 2x1500 MVA, 765/400 kV & 3x500 MVA, 400/220 kV pooling station at Bhadla-3 along with 2x330 MVAR (765 kV) Bus Reactor & 2x125 MVAR (420 kV) Bus Reactor</p> <ul style="list-style-type: none"> • 765/400 kV 1500 MVA ICTs: 2 Nos. (7x500 MVA including one spare unit) • 765 kV ICT bays - 2 Nos. • 400/220 kV, 500 MVA ICT – 3 Nos. • 765 kV line bays -2 Nos. • 400 kV ICT bays – 5 Nos. • 220 kV ICT bays - 3 Nos. • 220 kV line bays: 5 Nos. • 330 MVAR Bus Reactor-2 Nos. (7x110 MVAR, including one spare unit) • 765 kV reactor bay- 2 Nos. • 125 MVAR, 420 kV bus reactor - 2 Nos.

Sl. No.	Existing Scope	Revised Scope
	<ul style="list-style-type: none"> • 765 kV reactor bay- 2 Nos. • 125 MVAR, 420kV bus reactor - 2 Nos. • 420 kV reactor bay - 2 Nos. <p><u>Future provisions:</u> Space for</p> <ul style="list-style-type: none"> • 765/400 kV ICTs along with bays: 2 Nos. • 765 kV line bay along with switchable line reactor: 6 Nos. • 765 kV line bay: 4 Nos. • 765 kV Bus Reactor along with bays: 2 Nos. • 400/220 kV ICTs along with bays: 10 Nos. • 400 kV line bays: 8 Nos. • 400 kV line bays along with switchable line reactor: 6 Nos. • 400 kV Bus Reactor along with bays: 2 Nos. • 400 kV Sectionalization bay: 2 sets • 220 kV line bays: 12 Nos. • 220 kV sectionalization bay: 2 sets 	<ul style="list-style-type: none"> • 420 kV reactor bay - 2 Nos. <p><u>Future provisions:</u> Space for</p> <ul style="list-style-type: none"> • 765/400 kV ICTs along with bays: 2 Nos. • 765 kV line bay along with switchable line reactor: 6 Nos. • 765 kV line bay: 4 Nos. • 765 kV Bus Reactor along with bays: 2 Nos. • 400/220 kV ICTs along with bays: 10 Nos. • 400 kV line bays: 8 Nos. • 400 kV line bays along with switchable line reactors: 8 Nos. • 400 kV Bus Reactor along with bays: 2 Nos. • 400 kV Sectionalization bay: 2 sets • 220 kV line bays: 12 Nos. • 220 kV Sectionalization bay: 2 sets
2.	<p>Fatehgarh-2 PS – Bhadla-3 PS 400 kV D/c line (Quad moose) along with 63 MVAR Switchable line reactor for each circuit at both ends of Fatehgarh 2-Bhadla-3 400 kV D/c line</p> <ul style="list-style-type: none"> • 400 kV 63 MVAR switchable line reactor – 4 Nos. • Switching equipment for 400 kV 63 MVAR switchable line reactor – 4 Nos. 	Deleted
3.	<p>400 kV line bays at Fatehgarh-2 PS for Fatehgarh-2 PS – Bhadla-3 PS 400 kV D/c line</p> <ul style="list-style-type: none"> • 400 kV line bays - 2 Nos. 	Deleted
4.	<p>Bhadla-3 PS – Sikar-II S/s 765 kV D/c line along with 330 MVAR Switchable line reactor for each circuit at each end of</p>	<p>Bhadla-3 PS – Sikar-II S/s 765 kV D/c line along with 330 MVAR Switchable line reactor for each circuit at each end of Bhadla-</p>

Sl. No.	Existing Scope	Revised Scope
	Bhadla-3 PS – Sikar-II S/s 765 kV D/c line <ul style="list-style-type: none"> Switching equipment for 765 kV 330 MVAR switchable line reactor – 4 Nos. 765 kV, 330 MVAR Switchable line reactor- 4 Nos. 	3 PS – Sikar-II S/s 765 kV D/c line <ul style="list-style-type: none"> Switching equipment for 765 kV 330 MVAR switchable line reactor – 4 Nos. 765 kV, 330 MVAR Switchable line reactor- 4 Nos.
5.	765 kV line bays at Sikar-II <ul style="list-style-type: none"> 765 kV line bays – 2 Nos. 	765 kV line bays at Sikar-II <ul style="list-style-type: none"> 765 kV line bays – 2 Nos.
	<p>Note:</p> <ul style="list-style-type: none"> i. <i>Provision of suitable sectionalization shall be kept at Bhadla-3 at 400 kV & 220 kV level to limit short circuit level.</i> ii. <i>POWERGRID to provide space for 2 Nos. of 400 kV line bays along with space for switchable line reactors at Fatehgarh-2 S/s.</i> iii. <i>Developer of Sikar-II S/s to provide space for 2 Nos. of 765 kV line bays at Sikar-II S/s along with space for switchable line reactors.</i> iv. <i>Space provision for future 2 Nos. 220 kV Bus Coupler bay and 2 Nos. Transfer Bus Coupler Bay shall be kept for bus switching scheme requirement.</i> 	<p>Note:</p> <ul style="list-style-type: none"> i. <i>Provision of suitable sectionalization shall be kept at Bhadla-3 at 400 kV & 220 kV level to limit short circuit level.</i> ii. Deleted iii. <i>Developer of Sikar-II S/s to provide space for 2 Nos. of 765 kV line bays at Sikar-II S/s along with space for switchable line reactors.</i> iv. <i>Space provision for future 2 Nos. 220 kV Bus Coupler bay and 2 Nos. Transfer Bus Coupler Bay shall be kept for bus switching scheme requirement.</i>

4.3.6 After detailed deliberations, the revised scope of the scheme was approved by NCT. Revised scope of the scheme “Transmission system for evacuation of power from REZ in Rajasthan (20 GW) under Phase-III Part B1” is as follows:

Revised Scope
Establishment of 2x1500 MVA 765/400 kV & 3x500 MVA 400/220 kV pooling station at Bhadla-3 along with 2x330 MVAR (765 kV) Bus Reactor & 2x125 MVAR (420 kV) Bus Reactor <ul style="list-style-type: none"> 765/400 kV 1500 MVA ICTs: 2 Nos. (7x500 MVA including one spare unit) 765 kV ICT bays - 2 Nos. 400/220 kV, 500 MVA ICT – 3 Nos. 765 kV line bays -2 Nos. 400 kV ICT bays – 5 Nos. 220 kV ICT bays - 3 Nos. 220 kV line bays: 5 Nos. 330 MVAR Bus Reactor-2 Nos. (7x110 MVAR, including one spare unit)

Revised Scope
<ul style="list-style-type: none"> • 765 kV reactor bay- 2 Nos. • 125 MVAR, 420kV bus reactor - 2 Nos. • 420 kV reactor bay - 2 Nos. <p><u>Future provisions:</u> Space for</p> <ul style="list-style-type: none"> • 765/400 kV ICTs along with bays: 2 Nos. • 765 kV line bay along with switchable line reactor: 6 Nos. • 765 kV line bay: 4 Nos. • 765 kV Bus Reactor along with bays: 2 Nos. • 400/220 kV ICTs along with bays: 10 Nos. • 400 kV line bays: 8 Nos. • 400 kV line bays along with switchable line reactor: 8 Nos. • 400 kV Bus Reactor along with bays: 2 Nos. • 400 kV Sectionalization bay: 2 sets • 220 kV line bays: 12 Nos. • 220 kV Sectionalization bay: 2 sets
<p>Bhadla-3 PS – Sikar-II S/s 765 kV D/c line along with 330 MVAR Switchable line reactor for each circuit at each end of Bhadla-3 PS – Sikar-II S/s 765 kV D/c line</p> <ul style="list-style-type: none"> • Switching equipment for 765 kV 330 MVAR switchable line reactor – 4 Nos. • 765 kV, 330 MVAR Switchable line reactor- 4 Nos.
<p>765 kV line bays at Sikar-II</p> <ul style="list-style-type: none"> • 765 kV line bays – 2 Nos.
<p>Note:</p> <ol style="list-style-type: none"> i. <i>Provision of suitable sectionalization shall be kept at Bhadla-3 at 400 kV & 220 kV level to limit short circuit level.</i> ii. <i>Developer of Sikar-II S/s to provide space for 2 Nos. of 765 kV line bays at Sikar-II S/s along with space for switchable line reactors.</i> iii. <i>Space provision for future 2 Nos. 220 kV Bus Coupler bay and 2 Nos. Transfer Bus Coupler Bay shall be kept for bus switching scheme requirement.</i>

5 Comprehensive presentation by CTU apprising NCT of measures taken for ensuring development of an efficient, co-ordinated and economical ISTS for smooth flow of electricity.

CTUIL has prepared the rolling plan for 2027-28, which will be presented in the next NCT meeting.

6 Five-year rolling plan for ISTS capacity addition.

CTUIL has prepared the rolling plan for 2027-28, which will be presented in the next NCT meeting.

7 Any other issues, with permission of chair

The meeting ended with thanks to the chair.

Summary of the deliberations of the 14th meeting of NCT held on 09th June, 2023**I. ISTS communication schemes approved by NCT for implementation under RTM Route:**

Sl. No.	Name of Transmission Scheme	Implementation Mode	Implementation timeframe	Implementing Agency	Estimated Cost (Rs Cr)
1.	Requirement of additional FOTE of STM-16 capacity at Bhuj PS to cater to connectivity of RE Gencos	RTM	12 months	POWER GRID	0.6
2.	Requirement of additional FOTE of STM-16 capacity at Bhuj-II substation to cater to connectivity of RE Gencos	RTM	12 months	M/s PBTL	0.3
3.	Upgradation of STM-4 communication link of Dehgam, Ranchhodpura, Santhalpur Rep, Bhachau and CGPL Mundra to STM-16 capacity	RTM	12 months	POWER GRID	1.5

II. ISTS schemes costing less than Rs. 100 Crs. approved by NCT:

Sl. No.	Name of Transmission Scheme	Implementation Mode	Implementation timeframe	Allocated to	Estimated Cost (Rs Crs)
1.	Transmission System for Evacuation of Power from potential renewable energy zone in Khavda area of Gujarat under Phase-V (8 GW): Part A1 <u>Brief Scope:</u> Conversion of 330 MVAR Fixed LR at Wardha (on each ckt of Wardha – Raipur 765 kV D/c line	RTM	Matching with implementation of Khavda Phase-V Part A scheme viz. Bipole-1 (2x1500 MW) ±	POWER GRID	21

Sl. No.	Name of Transmission Scheme	Implementation Mode	Implementation timeframe	Allocated to	Estimated Cost (Rs Crs)
	being LILOed at Nagpur) into Bus Reactors at Wardha S/s		800 kV Nagpur (HVDC) [LCC] which is 48 months from SPV transfer.		
2.	<p>Transmission system for evacuation of power from Rajasthan REZ Ph-IV (Part-2 :5.5 GW) (Jaisalmer/Barmer Complex): Part H2</p> <p><u>Brief Scope:</u></p> <p>Provision of NGR bypass arrangement and inter tripping scheme on 240 MVAR SW LR at Bhopal end of Kurawar – Bhopal 765 kV S/c line (~60 km.):</p>	RTM	In matching timeframe of H1 Scheme	BDTCL i.e. the TSP owing the Indore – Bhopal 765 kV S/c line	0.45

III. ISTS Transmission schemes, costing between Rs 100 Crore to Rs 500 Crore, approved by NCT:

(a) The transmission schemes approved by NCT under RTM route is given below:

Sl. No.	Name of Transmission Scheme	Implementation Mode	Implementation timeframe	Allocated to	Estimated Cost (Rs. Crs)
1.	Augmentation of transformation capacity by 1x1500 MVA (3rd), 765/400 kV ICT at Maheshwaram (PG) substation in Telangana	RTM	21 months	POWERGRID	123.12

I/28785/2023

105

Sl. No.	Name of Transmission Scheme	Implementation Mode	Implementation timeframe	Allocated to	Estimated Cost (Rs. Crs)
2.	Transmission System for Evacuation of Power from potential renewable energy zone in Khavda area of Gujarat under Phase-IV (7 GW): Part E1	RTM	24 months	Khavda – Bhuj Transmission Ltd. (Subsidiary of Adani Transmission limited)	216
3.	Transmission System for Evacuation of Power from potential renewable energy zone in Khavda area of Gujarat under Phase-IV (7 GW): Part E3	RTM	24 months	KPS3 Transmission Limited (Subsidiary of POWERGRID)	216
4.	Transmission System for Evacuation of Power from potential renewable energy zone in Khavda area of Gujarat under Phase-IV (7 GW): Part E4	RTM	24 months	POWERGRID	235

(b) The transmission schemes approved by NCT to be implemented through TBCB route is given below:

Sl. No.	Name of Transmission Scheme	Implementation Mode	Tentative Implementation timeframe	Allocated to	Estimated Cost (Rs. Crs)	Survey Agency
1.	Western Region Network Expansion scheme in Kallam area of Maharashtra	TBCB	18 months	RECPD CL	160	RECPDCL

The broad scope of above ISTS scheme, approved by NCT for implementation through TBCB route to be notified in Gazette of India is as given below:

I/28785/2023

106

Sl. No.	Name of Scheme & Implementation timeframe	Broad Scope	Bid Process Coordinator
1.	Western Region Network Expansion scheme in Kallam area of Maharashtra Tentative Implementation Timeframe: 18 months from transfer of SPV	i. LILO of both circuits of Parli(M) – Karjat(M)/Lonikand-II(M) 400 kV D/c line (twin moose) at Kallam PS ii. 4 Nos. 400 kV line bays at Kallam PS for LILO of both circuits of Parli(M) – Karjat(M)/Lonikand-II(M) 400 kV D/c line (twin moose) at Kallam PS iii. 63 MVAR, 420 kV switchable line reactor (with NGR bypassing arrangement) on each ckt at Kallam PS end of Karjat – Kallam 400 kV D/c line (~140 km) (Detailed scope as approved by 14th NCT and subsequent amendments thereof)	RECPDCL

IV. ISTS Transmission schemes, costing greater than Rs 500 Crore recommended by NCT to MoP:

(a) The ISTS transmission schemes recommended by NCT to MoP are given below:

Sl. No.	Transmission Scheme	Implementation Mode	Tentative Implementation timeframe	Survey Agency	BPC	Estimated Cost (Rs. Crs)
1.	Transmission System for Evacuation of Power from potential renewable energy zone in Khavda area of Gujarat under Phase-IV (7 GW): Part A	TBCB	24 months from SPV Transfer	RECPDCL	RECPDCL	4,091
2.	Transmission System for Evacuation of Power from potential renewable	TBCB	24 months from	PFCCCL	PFCCCL	4,766

I/28785/2023

Sl. No.	Transmission Scheme	Implementation Mode	Tentative Implementation timeframe	Survey Agency	BPC	Estimated Cost (Rs. Crs)
	energy zone in Khavda area of Gujarat under Phase-IV (7 GW): Part B		SPV Transfer			
3.	Transmission System for Evacuation of Power from potential renewable energy zone in Khavda area of Gujarat under Phase-IV (7 GW): Part C	TBCB	24 months from SPV Transfer	RECPDCL	RECPDCL	5,340
4.	Transmission System for Evacuation of Power from potential renewable energy zone in Khavda area of Gujarat under Phase-IV (7 GW): Part D	TBCB	24 months from SPV Transfer	PFCCL	PFCCL	3,455
5.	Transmission System for Evacuation of Power from potential renewable energy zone in Khavda area of Gujarat under Phase-IV (7 GW): Part E2	TBCB	21 months from SPV Transfer	RECPDCL	RECPDCL	697
6.	Transmission System for Evacuation of Power from potential renewable energy zone in Khavda area of Gujarat under Phase-V (8 GW): Part A	TBCB	48 months for Bipole-1 and 54 months for Bipole-2 from SPV Transfer	RECPDCL	RECPDCL	24,819
7.	Transmission System for Evacuation of Power	TBCB	48 months	PFCCL	PFCCL	12,000

I/28785/2023

108

Sl. No.	Transmission Scheme	Implementation Mode	Tentative Implementation timeframe	Survey Agency	BPC	Estimated Cost (Rs. Crs)
	from potential renewable energy zone in Khavda area of Gujarat under Phase-V (8 GW): Part C		from SPV Transfer			
8.	Transmission system for evacuation of power from Rajasthan REZ Ph-IV (Part-2 :5.5 GW) (Jaisalmer/Barmer Complex): Part A	TBCB	24 months from SPV Transfer	RECPDCL	RECPDCL	2,206
9.	Transmission system for evacuation of power from Rajasthan REZ Ph-IV (Part-2 :5.5 GW) (Jaisalmer/Barmer Complex): Part B	TBCB	24 months from SPV Transfer	PFCCCL	PFCCCL	3,279
10.	Transmission system for evacuation of power from Rajasthan REZ Ph-IV (Part-2 :5.5 GW) (Jaisalmer/Barmer Complex): Part C	TBCB	24 months from SPV Transfer	CTUIL	RECPDCL	2,708
11.	Transmission system for evacuation of power from Rajasthan REZ Ph-IV (Part-2 :5.5 GW) (Jaisalmer/Barmer Complex): Part D	TBCB	24 months from SPV Transfer	CTUIL	PFCCCL	2,227
12.	Transmission system for evacuation of power from Rajasthan REZ Ph-IV (Part-2 :5.5 GW) (Jaisalmer/Barmer Complex): Part E	TBCB	24 months from SPV Transfer	RECPDCL	RECPDCL	3,251

I/28785/2023

Sl. No.	Transmission Scheme	Implementation Mode	Tentative Implementation timeframe	Survey Agency	BPC	Estimated Cost (Rs. Crs)
13.	Transmission system for evacuation of power from Rajasthan REZ Ph-IV (Part-2 :5.5 GW) (Jaisalmer/Barmer Complex): Part F (By clubbing Part F1 & F2)	TBCB	24 months from SPV Transfer	PFCCCL	PFCCCL	2,735
14.	Transmission system for evacuation of power from Rajasthan REZ Ph-IV (Part-2 :5.5 GW) (Jaisalmer/Barmer Complex): Part H1	TBCB	24 months from SPV Transfer	RECPDCL	RECPDCL	3,674

(b) The broad scope of ISTS schemes recommended by NCT to MoP for implementation through TBCB mode, to be notified in Gazette of India is as given below:

Sl. No.	Name of Scheme & Implementation timeframe	Broad Scope	Bid Process Coordinator
1.	Transmission System for Evacuation of Power from potential renewable energy zone in Khavda area of Gujarat under Phase-IV (7GW): Part A Tentative Implementation Timeframe: 24 months	<p>i. Creation of 765 kV bus section-II at KPS3 (GIS) along with 765 kV Bus Sectionaliser & 1x330MVAR, 765 kV Bus Reactors on Bus Section-II</p> <p>Bus section – II shall be created at 765 kV & 400 kV level both with 3x1500 MVA, 765/400 kV ICTs at Bus Section-II</p> <p>ii. Creation of 400 kV bus section-II at KPS3 (GIS) along with 400 kV Bus Sectionaliser & 1x125MVAR, 400 kV Bus Reactors on Bus Section-II and 3 Nos. 400 kV bays at Bus Section-II for RE interconnection</p>	RECPDCL

Sl. No.	Name of Scheme & Implementation timeframe	Broad Scope	Bid Process Coordinator
		iii. KPS3 (GIS) – Lakadia (AIS) 765 kV D/C line iv. 2 Nos. of 765 kV line bays each at KPS3 (GIS) & Lakadia (AIS) for KPS3 (GIS) – Lakadia (AIS) 765 kV D/C line v. ±300 MVAR STATCOM with 1x125 MVAR MSC, 2x125 MVAR MSR at KPS3 400 kV Bus section-2 vi. KPS1 (GIS)– Bhuj PS 765 kV 2 nd D/C line vii. 2 Nos. of 765 kV line bays each at KPS1 (GIS) & Bhuj PS for KPS1 (GIS) – Bhuj PS 765 kV D/C line viii. 330 MVAR, 765 kV switchable line reactors at KPS3 end of KPS3 (GIS) – Lakadia 765 kV D/C line (with NGR bypass arrangement) (Detailed scope as approved by 14th NCT and subsequent amendments thereof)	
2.	Transmission System for Evacuation of Power from potential renewable energy zone in Khavda area of Gujarat under Phase-IV (7 GW): Part B Tentative Implementation timeframe: 24 months from SPV transfer	i. Establishment of 2x1500 MVA, 765/400 kV & 2x500 MVA, 400/220 kV GIS S/s at a suitable location South of Olpad (between Olpad and Ichhapore) with 2x330 MVAR, 765 kV & 1x125 MVAR, 420 kV bus reactors. ii. Vadodara(GIS) – South Olpad (GIS) 765 kV D/C line iii. 240 MVAR switchable line	PFCCL

I/28785/2023

Sl. No.	Name of Scheme & Implementation timeframe	Broad Scope	Bid Process Coordinator
		<p>reactors on each ckt at Vadodara(GIS) end of Vadodara(GIS) –South Olpad(GIS) 765 kV D/C line (with NGR bypass arrangement)</p> <p>iv. 2 Nos. of 765 kV line bays at Vadodara(GIS) for Vadodara(GIS) – South olpad(GIS) 765 kV D/C line</p> <p>v. LILO of Gandhar – Hazira 400 kV D/c line at South Olpad (GIS) using twin HTLS conductor with minimum capacity of 1700MVA per ckt at nominal voltage</p> <p>vi. Ahmedabad – South Olpad(GIS) 765 kV D/c line</p> <p>vii. 240 MVAR switchable line reactors on each ckt at Ahmedabad & South Olpad (GIS) end of Ahmedabad – South Olpad(GIS) 765 kV D/c line (with NGR bypass arrangement)</p> <p>viii. 2 Nos. of 765 kV line bays at Ahmedabad S/s for Ahmedabad – South Olpad(GIS) 765 kV D/c line</p> <p>(Detailed scope as approved by 14th NCT and subsequent amendments thereof)</p>	
3.	Transmission System for Evacuation of Power from potential renewable energy zone in Khavda area of Gujarat under Phase-IV (7 GW): Part C	i. Establishment of 4x1500 MVA 765/400 kV & 2x500 MVA 400/220 kV Boisar-II (GIS) with 2x330 MVAR, 765 kV bus reactor and 2x125 MVAR, 420 kV bus reactor. [2x1500 MVA, 765/400 kV ICTs shall be on each 400 kV section and	RECPDCL

I/28785/2023

Sl. No.	Name of Scheme & Implementation timeframe	Broad Scope	Bid Process Coordinator
	Tentative Implementation timeframe: 24 months from SPV transfer	<p>2x500MVA, 400/220 kV ICTs shall be on 400 kV bus section-II. 2x125MVAR Bus reactors shall be such that one bus reactor is placed on each 400 kV bus section. 400 kV Bus Sectionalizer to be kept under normally OPEN condition.]</p> <p>ii. South Olpad (GIS) – Boisar-II (GIS) 765 kV D/c line</p> <p>iii. 2 Nos. of 765 kV line bays at South Olpad (GIS) for termination of South Olpad (GIS) – Boisar-II (GIS) 765 kV D/c line</p> <p>iv. 240 MVAR switchable line reactors on each ckt at South Olpad(GIS) & Boisar-II(GIS) end of South Olpad(GIS) – Boisar-II(GIS) 765 kV D/c line (with NGR bypass arrangement)</p> <p>v. LILO of Navsari(New) – Padghe(PG) 765 kV D/c line at Boisar-II</p> <p>vi. Boisar-II (Sec-II) – Velgaon(MH) 400 kV D/c (Quad ACSR/AAAC/AL59 moose equivalent) line</p> <p>vii. 2 Nos. of 400 kV line bays at Velgaon(MH) for termination of Boisar-II – Velgaon(MH) 400 kV D/c (Quad ACSR/AAAC/AL59 moose equivalent) line</p> <p>viii. LILO of Babhaleswar – Padghe (M) 400 kV D/c line at Boisar-II (Sec-I) using twin HTLS</p>	

I/28785/2023

113

Sl. No.	Name of Scheme & Implementation timeframe	Broad Scope	Bid Process Coordinator
		<p>conductor with minimum capacity of 1700 MVA per ckt at nominal voltage</p> <p>ix. 80 MVAR switchable line reactors at Boisar-II end of Boisar-II – Babhaleswar 400 kV D/c line (with NGR bypass arrangement) formed after above LILO</p> <p>x. ±200MVAR STATCOM with 2x125 MVAR MSC, 1x125 MVAR MSR at 400 kV bus section-I of Boisar-II and ±200MVAR STATCOM with 2x125 MVAR MSC, 1x125 MVAR MSR at 400 kV bus section-II of Boisar-II</p> <p>xi. ± 300 MVAR STATCOM with 3x125 MVAR MSC, 1x125 MVAR MSR at 400 kV level of Navsari(New)(PG) S/s with 1 No. of 400 kV bay (GIS)</p> <p>(Detailed scope as approved by 14th NCT and subsequent amendments thereof)</p>	
4.	<p>Transmission System for Evacuation of Power from potential renewable energy zone in Khavda area of Gujarat under Phase-IV (7 GW): Part D</p> <p>Tentative Implementation timeframe: 24 months from SPV transfer</p>	<p>i. Establishment of 2x1500 MVA 765/400 kV & 3x500 MVA 400/220 kV Pune-III (GIS) S/s with 2x330 MVAR, 765 kV bus reactor and 2x125 MVAR, 420 kV bus reactor.</p> <p>ii. Boisar-II – Pune-III 765 kV D/c line</p> <p>iii. 330 MVAR switchable line reactors at Pune-III end of Boisar-II – Pune-III 765 kV D/c line (with NGR bypass</p>	PFCCL

I/28785/2023

Sl. No.	Name of Scheme & Implementation timeframe	Broad Scope	Bid Process Coordinator
		<p>arrangement).</p> <p>iv. 2 Nos. of 765 kV line bays at Boisar-II for termination of Boisar-II – Pune-III 765 kV D/c line</p> <p>v. LILO of Narendra (New) – Pune(GIS) 765 kV D/c line at Pune-III</p> <p>vi. 330 MVAR switchable line reactors at Pune-III end of Narendra (New) – Pune-III (GIS) 765 kV D/c line (with NGR bypass arrangement).</p> <p>vii. LILO of Hinjewadi - Koyna 400 kV S/c line at Pune-III(GIS) S/s</p> <p>viii. 80 MVAR, 420 kV switchable Line Reactors on each ckt at Pune-III (GIS) end of Pune-III (GIS) – Koyna 400 kV line formed after above LILO (with NGR bypass arrangement).</p> <p>(Detailed scope as approved by 14th NCT and subsequent amendments thereof)</p>	
5.	<p>Transmission System for Evacuation of Power from potential renewable energy zone in Khavda area of Gujarat under Phase-IV (7 GW): Part E2</p> <p>Tentative Implementation timeframe: 21 months from SPV transfer</p>	<p>i. Augmentation of transformation capacity at KPS2 (GIS) by 2x1500 MVA, 765/400 kV ICT on Bus Section-I (5th & 6th) & 2x1500 MVA, 765/400 kV ICT on Bus section-II (7th & 8th) & 2 Nos. 400 kV bays at Bus Section-I for RE interconnection and 3 Nos. 400 kV bays at Bus Section-II for RE interconnection</p> <p>(Detailed scope as approved by 14th NCT and subsequent</p>	RECPDCL

Sl. No.	Name of Scheme & Implementation timeframe	Broad Scope	Bid Process Coordinator
		amendments thereof)	
6.	<p>Transmission System for Evacuation of Power from potential renewable energy zone in Khavda area of Gujarat under Phase-V (8 GW): Part A</p> <p>Tentative Implementation timeframe: 48 months for Bipole-1 (2x1500MW) and 54 months for Bipole-2 (2x1500MW)</p>	<p>i. Establishment of 6000 MW, ± 800 kV KPS2 (HVDC) [LCC] terminal station (4x1500 MW) along with associated interconnections with 400 kV HVAC Switchyard</p> <p>ii. Establishment of 6000 MW, ± 800 kV Nagpur (HVDC) [LCC] terminal station (4x1500 MW) along with associated interconnections with 400 kV HVAC Switchyard</p> <p>iii. ± 800 kV HVDC Bipole line (Hexa lapwing) between KPS2(HVDC) and Nagpur (HVDC) (1200 km) (with Dedicated Metallic Return) (capable to evacuate 6000 MW with overload as specified)</p> <p>iv. Establishment of 6x1500 MVA, 765/400 kV ICTs at Nagpur S/s along with 2x330 MVAR (765 kV) & 2x125 MVAR, 420 kV bus reactors along with associated interconnections with HVDC Switchyard. The 400 kV bus shall be established in 2 sections through 1 set of 400 kV bus sectionaliser so that 3x1500 MVA ICTs are placed in each section. The bus sectionaliser shall be normally CLOSED and may be opened based on Grid requirement.</p> <p>v. LILO of Wardha – Raipur 765 kV one D/c line (out of 2xD/c</p>	PFCCCL

I/28785/2023

116

Sl. No.	Name of Scheme & Implementation timeframe	Broad Scope	Bid Process Coordinator
		<p>lines) at Nagpur.</p> <p>vi. Installation of 240 MVAR switchable line reactor at Nagpur end on each ckt of Nagpur – Raipur 765 kV D/c line.</p> <p>(Detailed scope as approved by 14th NCT and subsequent amendments thereof)</p>	
7.	<p>Transmission System for Evacuation of Power from potential renewable energy zone in Khavda area of Gujarat under Phase-V (8GW): Part C</p> <p>Tentative Implementation timeframe: 48 months from SPV transfer</p>	<p>i. Establishment of 2500 MW, ± 500 kV KPS3 (HVDC) [VSC] terminal station (2x1250 MW) at a suitable location near KPS3 substation with associated interconnections with 400 kV HVAC Switchyard</p> <p>ii. Establishment of 2500 MW, ± 500 kV South Olpad (HVDC) [VSC] terminal station (2x1250 MW) along with associated interconnections with 400 kV HVAC Switchyard of South Olpad S/s</p> <p>iii. Establishment of KPS3 (HVDC) S/s along with 2x125MVAR, 420kV bus reactors along with associated interconnections with HVDC Switchyard. The 400 kV bus shall be established in 2 sections through 1 set of 400 kV bus sectionaliser to be kept normally OPEN.</p> <p>400/33 kV, 2x50 MVA transformers for exclusively supplying auxiliary power to HVDC terminal.</p> <p>iv. KPS3 – KPS3 (HVDC) 400 kV 2xD/c (Quad ACSR /AAAC /</p>	RECPDCL

Sl. No.	Name of Scheme & Implementation timeframe	Broad Scope	Bid Process Coordinator
		<p>AL59 moose equivalent) line along with the line bays at both substations</p> <p>v. ± 500 kV HVDC Bipole line between KPS3(HVDC) and South Olpad (HVDC) (with Dedicated Metallic Return) (capable to evacuate 2500 MW)</p> <p>(Detailed scope as approved by 14th NCT and subsequent amendments thereof)</p>	
8.	<p>Transmission system for evacuation of power from Rajasthan REZ Ph-IV (Part-2 :5.5 GW) (Jaisalmer/Barmer Complex): Part A</p> <p>Tentative Implementation timeframe: 24 months from SPV transfer</p>	<p>i. Establishment of 4x1500 MVA, 765/400 kV & 5x500 MVA, 400/220 kV Fatehgarh-IV (Section-2) Pooling Station along with 2x240 MVAR (765 kV) Bus Reactor & 2x125 MVAR (420 kV) Bus Reactor</p> <p>ii. Fatehgarh-IV (Section-2) PS – Bhinmal (PG) 400 kV D/c line (Twin HTLS) along with 50 MVAR switchable line reactor on each ckt. at each end</p> <p>iii. LILO of both ckts of 765 kV Fatehgarh-III- Beawar D/c line (2nd) at Fatehgarh-IV (Section-2) PS along with 330 MVAR switchable line reactor at Fatehgarh-IV PS end of each ckt of 765 kV Fatehgarh-IV- Beawar D/c line (formed after LILO)</p> <p>iv. 2 Nos. of 400 kV line bays at Bhinmal (PG)</p> <p>(Detailed scope as approved by 14th NCT and subsequent amendments thereof)</p>	PFCCL

Sl. No.	Name of Scheme & Implementation timeframe	Broad Scope	Bid Process Coordinator
9.	<p>Transmission system for evacuation of power from Rajasthan REZ Ph-IV (Part-2 :5.5 GW) (Jaisalmer/Barmer Complex): Part B</p> <p>Tentative Implementation timeframe: 24 months from SPV transfer</p>	<p>i. Establishment of 2x1500 MVA, 765/400 kV Substation at suitable location near Sirohi along with 2x240 MVAR (765 kV) & 2x125 MVAR (420 kV) Bus Reactor</p> <p>ii. Fatehgarh-IV (Section-2) PS – Sirohi PS 765 kV D/c line along with 240 MVAR switchable line reactor for each circuit at each end</p> <p>iii. Sirohi PS-Chittorgarh (PG) 400 kV D/c line (Quad) along with 80 MVAR switchable line reactor for each circuit at Sirohi PS end.</p> <p>iv. 2 No. of 400 kV line bays at Chittorgarh (PG) S/s</p> <p>v. 2 No. of 765 kV line bays at Fatehgarh-IV (Section-2) PS</p> <p>(Detailed scope as approved by 14th NCT and subsequent amendments thereof)</p>	RECPDCL
10.	<p>Transmission system for evacuation of power from Rajasthan REZ Ph-IV (Part-2 :5.5 GW) (Jaisalmer/Barmer Complex): Part C</p> <p>Tentative Implementation timeframe: 24 months from SPV transfer</p>	<p>i. Establishment of 3x1500 MVA, 765/400 kV & 5x500 MVA, 400/220 kV Mandsaur Pooling Station along with 2x330 MVAR (765 kV) Bus Reactors & 2x125 MVAR, 420 kV Bus Reactor.</p> <p>ii. Mandsaur PS – Indore(PG) 765 kV D/c Line</p> <p>iii. 1x330 MVAR, 765 kV switchable line reactor (SLR) on each ckt at Mandsaur end of Mandsaur PS – Indore (PG) 765</p>	PFCCL

I/28785/2023

Sl. No.	Name of Scheme & Implementation timeframe	Broad Scope	Bid Process Coordinator
		kV D/c Line iv. 2 Nos. of 765 kV line bays at Indore(PG) for termination of Mandsaur PS – Indore(PG) 765 kV D/c Line (Detailed scope as approved by 14th NCT and subsequent amendments thereof)	
11.	Transmission system for evacuation of power from Rajasthan REZ Ph-IV (Part-2 :5.5 GW) (Jaisalmer/Barmer Complex): Part D Tentative Implementation timeframe: 24 months from SPV transfer	i. Beawar- Mandsaur PS 765 kV D/c line along with 240 MVAR switchable line reactor for each circuit at each end ii. 2 Nos. of 765 kV line bays each at Beawar S/s & Mandsaur S/s (Detailed scope as approved by 14th NCT and subsequent amendments thereof)	RECPDCL
12.	Transmission system for evacuation of power from Rajasthan REZ Ph-IV (Part-2 :5.5 GW) (Jaisalmer/Barmer Complex): Part E Tentative Implementation timeframe: 24 months from SPV transfer	i. Establishment of, 765 kV Substation at suitable location near Rishabdeo (Distt. Udaipur) along with 2x240 MVAR (765 kV) Bus Reactor ii. Sirohi PS- Rishabdeo 765 kV D/c line along with 330 MVAR switchable line reactor for each circuit at Sirohi end iii. Rishabdeo - Mandsaur PS 765 kV D/c line along with 240 MVAR switchable line reactor for each circuit at Rishabdeo end iv. LILO of one circuit of 765 kV Chittorgarh-Banaskanta D/c line at Rishabdeo S/s v. 2 Nos. of 765 kV line bays each	PFCCCL

Sl. No.	Name of Scheme & Implementation timeframe	Broad Scope	Bid Process Coordinator
		at Sirohi PS & Mandsaur S/s (Detailed scope as approved by 14th NCT and subsequent amendments thereof)	
13.	Transmission system for evacuation of power from Rajasthan REZ Ph-IV (Part-2 :5.5 GW) (Jaisalmer/Barmer Complex): Part F [by clubbing Part F1 & F2] Tentative Implementation timeframe: 24 months from SPV transfer	<ul style="list-style-type: none"> i. Establishment of 3x1500 MVA, 765/400 kV& 2x500 MVA, 400/220 kV Barmer-I Pooling Station along with 2x240 MVAR (765 kV) Bus Reactor & 2x125 MVAR (420 kV) Bus Reactor ii. Fatehgarh-III (Section-2) PS – Barmer-I PS 400 kV D/c line (Quad) iii. Barmer-I PS– Sirohi PS 765 kV D/c line along with 240 MVAR switchable line reactor for each circuit at each end iv. 2 Nos. of 400 kV line bays at Fatehgarh-III (Section-2) PS v. 2 Nos. of 765 kV line bays at Sirohi PS (Detailed scope as approved by 14th NCT and subsequent amendments thereof)	RECPDCL
14.	Transmission system for evacuation of power from Rajasthan REZ Ph-IV (Part-2 :5.5 GW) (Jaisalmer/Barmer Complex): Part H1 Tentative Implementation timeframe: 24 months from SPV transfer	<ul style="list-style-type: none"> i. Establishment of 765/400 (2x1500 MVA), 400/220 (2x500 MVA) & 220/132 kV (3x200 MVA) Kurawar S/s with 2x330 MVAR, 765 kV bus reactor and 1x125 MVAR, 420 kV bus reactor. ii. Mandsaur – Kurawar 765 kV D/c line. iii. 240 MVAR switchable line 	PFCCL

I/28785/2023

Sl. No.	Name of Scheme & Implementation timeframe	Broad Scope	Bid Process Coordinator
		<p>reactors on each ckt at both ends of Mandsaur – Kurawar 765 kV D/c line.</p> <p>iv. 2 Nos. of 765 kV line bays at Mandsaur S/s for termination of Mandsaur – Kurawar 765 kV D/c line.</p> <p>v. LILO of Indore – Bhopal 765 kV S/c line at Kurawar.</p> <p>vi. Kurawar – Ashtha 400 kV D/c (Quad ACSR/AAAC/AL59 moose equivalent) line.</p> <p>vii. 2 Nos. of 400 kV line bays at Ashtha (MP) S/s for termination of Kurawar – Ashtha 400 kV D/c line.</p> <p>viii. LILO of one circuit of Indore – Itarsi 400 kV D/c line at Astha</p> <p>ix. 2 Nos. of 400 kV line bays at Ashtha (MP) S/s for LILO of one circuit of Indore – Itarsi 400 kV D/c line at Astha</p> <p>x. Shujalpur – Kurawar 400 kV D/c (Quad ACSR/AAAC/AL59 moose equivalent) line</p> <p>xi. 2 Nos. of 400 kV line bays at Shujalpur(PG) S/s for termination of Shujalpur – Kurawar 400 kV D/c line</p> <p>(Detailed scope as approved by 14th NCT and subsequent amendments thereof)</p>	

V. Modification in the earlier approved/notified transmission schemes:

(a) Revised timeframe of the transmission scheme “Transmission system for evacuation of power from Luhri Stage-I HEP”

The timeframe of the transmission scheme “Transmission system for evacuation of power from Luhri Stage-I HEP”, would be revised to 31st August, 2026, in the matching timeframe of Luhri Stage-I HEP.

(b) Delinking of Fatehgarh-II- Bhadla-III 400 kV D/c line from transmission scheme “Transmission system for evacuation of power from REZ in Rajasthan (20 GW) under Phase-III Part B1”:

Revised scope of the scheme “Transmission system for evacuation of power from REZ in Rajasthan (20 GW) under Phase-III Part B1” is as follows:

Revised Scope
<p>Establishment of 2x1500 MVA 765/400 kV & 3x500 MVA 400/220 kV pooling station at Bhadla-3 along with 2x330 MVAR (765 kV) Bus Reactor & 2x125 MVAR (420 kV) Bus Reactor</p> <ul style="list-style-type: none"> • 765/400 kV 1500 MVA ICTs: 2 Nos. (7x500 MVA including one spare unit) • 765 kV ICT bays - 2 Nos. • 400/220 kV, 500 MVA ICT – 3 Nos. • 765 kV line bays -2 Nos. • 400 kV ICT bays – 5 Nos. • 220 kV ICT bays - 3 Nos. • 220 kV line bays: 5 Nos. • 330 MVAR Bus Reactor-2 Nos. (7x110 MVAR, including one spare unit) • 765 kV reactor bay- 2 Nos. • 125 MVAR, 420kV bus reactor - 2 Nos. • 420 kV reactor bay - 2 Nos. <p><u>Future provisions:</u> Space for</p>

Revised Scope
<ul style="list-style-type: none"> • 765/400 kV ICTs along with bays: 2 Nos. • 765 kV line bay along with switchable line reactor: 6 Nos. • 765 kV line bay: 4 Nos. • 765 kV Bus Reactor along with bays: 2 Nos. • 400/220 kV ICTs along with bays: 10 Nos. • 400 kV line bays: 8 Nos. • 400 kV line bays along with switchable line reactor: 8 Nos. • 400 kV Bus Reactor along with bays: 2 Nos. • 400 kV Sectionalization bay: 2 sets • 220 kV line bays: 12 Nos. • 220 kV sectionalization bay: 2 sets
<p>Bhadla-3 PS – Sikar-II S/s 765 kV D/c line along with 330 MVAR Switchable line reactor for each circuit at each end of Bhadla-3 PS – Sikar-II S/s 765 kV D/c line</p> <ul style="list-style-type: none"> • Switching equipment for 765 kV 330 MVAR switchable line reactor – 4 Nos. • 765 kV, 330 MVAR Switchable line reactor- 4 Nos.
<p>765 kV line bays at Sikar-II</p> <ul style="list-style-type: none"> • 765 kV line bays – 2 Nos.
<p>Note:</p> <p>iv. <i>Provision of suitable sectionalization shall be kept at Bhadla-3 at 400 kV & 220 kV level to limit short circuit level.</i></p> <p>v. <i>Developer of Sikar-II S/s to provide space for 2 Nos. of 765 kV line bays at Sikar-II S/s along with space for switchable line reactors.</i></p> <p>vi. <i>Space provision for future 2 Nos. 220 kV Bus Coupler bay and 2 Nos. Transfer Bus Coupler Bay shall be kept for bus switching scheme requirement.</i></p>

Annex-I**List of Participants of the 14th meeting of NCT****CEA:**

1. Sh. Ghanshyam Prasad, Chairperson, CEA and Chairman, NCT
2. Sh. A. K. Rajput, Member (Power Systems)
3. Sh. Ajay Talegaonkar, Member (E&C)
4. Sh. Ishan Sharan, Chief Engineer (PSPA-I)
5. Sh. Upendra Kumar, Chief Engineer (PCD)
6. Sh. B.S. Bairwa, Director (PSPA-II)
7. Sh. Deepanshu Rastogi, Deputy Director (PSPA-II)
8. Sh. Manish Maurya, Deputy Director (PSPA-II)
9. Sh. Pranay Garg, Deputy Director (PSPA-II)
10. Sh. Kanhaiya Singh Kushwaha, Assistant Director (PSPA-I)
11. Sh. Ajay Malav, Assistant Director (PSPA-II)

MoP:

1. Sh. Om Kant Shukla, Director (Trans.)

MNRE:

1. Sh. Tarun Singh, Scientist D

SECI:

1. Sh. Sanjay Sharma, Director
2. Sh. R.K. Agarwal, Consultant

CTUIL:

1. Sh. P.C. Garg, COO
2. Sh. Ashok Pal, Deputy COO
3. Sh. Jasbir Singh, CGM
4. Sh. Sourov Chakraborty, CGM
5. Sh. P.S Das, Senior GM
6. Sh. V Thiagarajan, Senior GM
7. Sh. Kashish Bhambhani, GM
8. Sh. Sandeep Kumawat, DGM
9. Sh. Chinmay Sharma, Chief Manager
10. Sh. Pratyush Singh, Chief Manager

GRID India:

1. Sh. Rajiv Porwal, ED
2. Sh. Surajit Banerjee, CGM
3. Sh. Vivek Pandey, GM
4. Sh. Priyam Jain, Manager

Expert Member:

1. Ms. Seema Gupta
2. Dr. Radheshyam Saha



भारत का राजपत्र

The Gazette of India

सी.जी.-डी.एल.-अ.-11082023-248014
CG-DL-E-11082023-248014

असाधारण
EXTRAORDINARY

भाग III—खण्ड 4
PART III—Section 4

प्राधिकार से प्रकाशित
PUBLISHED BY AUTHORITY

सं. 560]
No. 560]

नई दिल्ली, बृहस्पतिवार, अगस्त 10, 2023/श्रावण 19, 1945
NEW DELHI, THURSDAY, AUGUST 10, 2023/SHRAVANA 19, 1945

केंद्रीय विद्युत प्राधिकरण

अधिसूचना

नई दिल्ली, 19 जुलाई, 2023

फ़ा. सं. CEA-PS-12-13/3/2022-PSPA-II Division.—विद्युत अधिनियम, 2003 (2003 की संख्या 36) की धारा 63 के तहत बनाई गई पारेषण सेवाओं के लिए टैरिफ आधारित प्रतिस्पर्धी बोली दिशानिर्देशों के पैरा 3.2 और विद्युत मंत्रालय के कार्यालय आदेश दिनांक 28.10.2021 द्वारा प्रदत्त शक्तियों का प्रयोग करते हुए, राष्ट्रीय पारेषण समिति (एनसीटी) (अध्यक्ष, केंद्रीय विद्युत प्राधिकरण की अध्यक्षता में), पारेषण योजना के लिए निम्नलिखित बोली-प्रक्रिया समन्वयक (बीपीसी) नियुक्त करती है, जैसा कि पारेषण योजना के नाम के आगे दर्शाया गया है:

क्रम. सं.	पारेषण योजना का नाम तथा अनुमानित कार्यान्वयन समय सीमा	पारेषण योजना का व्यापक दायरा *	बोली-प्रक्रिया समन्वयक (बीपीसी)
1	महाराष्ट्र के कल्लम क्षेत्र में पश्चिमी क्षेत्र नेटवर्क विस्तार योजना अनुमानित कार्यान्वयन समय सीमा: एसपीवी के स्थानांतरण से 18 महीने	i) कल्लम पीएस पर परली (एम) - कर्जत (एम)/लोनीकांड-II(एम) 400 केवी डी/सी लाइन (ट्रिवन मूस) के दोनों सर्किटों का लीलो ii) कल्लम पीएस पर परली (एम) - कर्जत (एम)/लोनीकांड-II(एम) 400 केवी डी/सी लाइन (ट्रिवन मूस) के दोनों सर्किटों का लीलो के लिए कल्लम पीएस में 400 केवी के 4 लाइन बे	आरईसीपीडीसीएल

		iii) कर्जत-कल्लम 400 केवी डी/सी लाइन (~140 किमी) के कल्लम पीएस छोर पर प्रत्येक सर्किट पर 63 एमवीएआर, 420 केवी के स्विचेबल लाइन रिएक्टर (एनजीआर बाईपास व्यवस्था के साथ)	
--	--	--	--

*पारेषण योजना का विस्तृत कार्यक्षेत्र राष्ट्रीय पारेषण समिति की 14 वीं बैठक के कार्यवृत्त और बाद के संशोधन, में निम्नलिखित लिंक पर देखा जा सकता है:

https://cea.nic.in/wp-content/uploads/comm_transmission/2023/07/14th_NCT_MoM.pdf

बोली-प्रक्रिया समन्वयक की नियुक्ति दिशानिर्देशों में निर्धारित शर्तों के अधीन है।

राकेश कुमार, सचिव

[विज्ञापन III/4/असा./340/2023-24]

CENTRAL ELECTRICITY AUTHORITY

NOTIFICATION

New Delhi, the 19th July, 2023

F. No. CEA-PS-12-13/3/2022-PSPA-II Division.—In exercise of the powers conferred by Para 3.2 of the Tariff Based Competitive Bidding Guidelines for Transmission Services framed under Section 63 of the Electricity Act, 2003 (no. 36 of 2003) and Ministry of Power office order dated 28.10.2021, National Committee on Transmission (NCT) headed by Chairperson, Central Electricity Authority hereby appoints the following Bid-Process Coordinator (BPC) for the Transmission Schemes, as shown against the name of the Transmission schemes:

Sl. No.	Name of Scheme & Tentative Implementation timeframe	Broad Scope of the transmission scheme *	Bid Process Coordinator
1	Western Region Network Expansion scheme in Kallam area of Maharashtra Tentative Implementation Timeframe: 18 months from transfer of SPV	i) LILO of both circuits of Parli(M) – Karjat(M)/Lonikand-II (M) 400 kV D/c line (twin moose) at Kallam PS ii) 4 Nos. 400 kV line bays at Kallam PS for LILO of both circuits of Parli(M) – Karjat(M)/Lonikand-II(M) 400 kV D/c line (twin moose) at Kallam PS iii) 63 MVAR, 420 kV switchable line reactor (with NGR bypassing arrangement) on each ckt at Kallam PS end of Karjat – Kallam 400 kV D/c line (~140km.)	RECPDCL

*Detailed scope may be seen in the minutes of the 14th meeting of the National Committee on Transmission and subsequent amendments, available at:

https://cea.nic.in/wp-content/uploads/comm_transmission/2023/07/14th_NCT_MoM.pdf

The appointment of the Bid-Process Coordinators is subject to the conditions laid down in the Guidelines.

RAKESH KUMAR, Secy.

[ADVT.-III/4/Exty./340/2023-24]

**STANDARD SINGLE STAGE REQUEST FOR
PROPOSAL DOCUMENT**

FOR

**SELECTION OF BIDDER AS TRANSMISSION
SERVICE PROVIDER THROUGH TARIFF BASED
COMPETITIVE BIDDING PROCESS**

TO

ESTABLISH INTER-STATE TRANSMISSION SYSTEM

FOR

**WESTERN REGION NETWORK EXPANSION SCHEME
IN KALLAM AREA OF MAHARASHTRA**

ISSUED BY

**REC Power Development and Consultancy Limited
(A wholly owned subsidiary of REC Limited)**

**Registered Office:
Core-4, SCOPE Complex,
7, Lodhi Road, New Delhi – 110 003
Email: pshariharan@recpdcl.in & tbc@recpdcl.in**

13.10.2023

**REC Power Development and Consultancy Limited
(A wholly owned subsidiary of REC Limited)
Core-4, SCOPE Complex,
7, Lodhi Road, New Delhi – 110 003**

Request for Proposal Document for selection of Bidder as Transmission Service Provider through tariff based competitive bidding process to establish Inter-State Transmission system for “Western Region Network Expansion scheme in Kallam area of Maharashtra” is issued by REC Power Development and Consultancy Limited.

This RFP document is issued to -

M/s. _____

**Chief Executive Officer,
REC Power Development and Consultancy Limited
(A wholly owned subsidiary of REC Limited)**

Email:

Place:

Date:

Signature:

REQUEST FOR PROPOSAL NOTIFICATION

REC Power Development and Consultancy Limited
(A wholly owned subsidiary of REC Limited)
Core-4, SCOPE Complex,
7, Lodhi Road, New Delhi – 110 003

1. Central Electricity Authority (CEA), Government of India vide its notification no 560 [F No. CEA-PS-12-13/3/2022-PSPA-II Division] dated 10.08.2023 has notified REC Power Development and Consultancy Limited (RECPDCL) to be the Bid Process Coordinator (BPC) for the purpose of selection of Bidder as Transmission Service Provider (TSP) to establish Inter-State transmission system for “**Western Region Network Expansion scheme in Kallam area of Maharashtra**” through tariff based competitive bidding process.
2. REC Power Development and Consultancy Limited (hereinafter referred to as BPC) hereby invites all prospective Bidders for issue of Request for Proposal (RFP) for selection of Bidder as Transmission Service Provider (TSP) on the basis of international competitive bidding in accordance with the “Tariff Based Competitive Bidding Guidelines for Transmission Service” and “Guidelines for Encouraging Competition in Development of Transmission Projects” issued by Government of India, Ministry of Power under section – 63 of The Electricity Act, 2003 and as amended from time to time. The responsibility of the TSP would be to establish the following Inter-State Transmission System - **Western Region Network Expansion scheme in Kallam area of Maharashtra** (hereinafter referred to as 'Project') on build, own, operate & transfer basis and to provide transmission service:

Sl. No.	Scope of the Transmission Scheme	Scheduled COD in months from Effective Date
1	LILO of both circuits of Parli(M) – Karjat(M)/Lonikand-II (M) 400 kV D/c line (twin moose) at Kallam PS	18 months
2	4 Nos. 400 kV line bays at Kallam PS for LILO of both circuits of Parli(M) – Karjat(M)/Lonikand-II(M) 400 kV D/c line (twin moose) at Kallam PS <ul style="list-style-type: none"> • 400 kV line bays (AIS) – 4 Nos. (for Kallam PS end) 	
3	63 MVAR, 420 kV switchable line reactor (with NGR bypassing arrangement) on each ckt at Kallam PS end of Karjat – Kallam 400 kV D/c line (~140km) <ul style="list-style-type: none"> • 63 MVAR, 420 kV switchable line reactor including Switching equipment - 2 Nos. (at Kallam end) 	

Note:

- a) TSP of Kallam PS (Kallam Transmission Ltd.) shall provide requisite space at Kallam PS for above mentioned scope of work.
- b) The 50 MVAR fixed line reactors on each ckt at Parli (M) end of Kallam – Parli (M) 400 kV D/c line shall be converted into switchable line reactors (with NGR bypass arrangement & provision of inter-tripping scheme to trip the line reactors along with the main line breakers) by MSETCL in matching time-frame of the above scheme.

MSETCL vide email dated 08.06.2023 has informed that conversion of fixed 50 MVAR line reactor at 400 kV Parli (M) (Girwali) end into switchable reactor is feasible.

3. The TSP shall ensure that design, construction and testing of all equipment, facilities, components and systems of the Project shall be in accordance with the provisions of the Transmission Service Agreement and applicable Rules/ Regulations, Orders and Guidelines issued by the Central Government.
4. **Transmission License:** The TSP shall obtain the Transmission License from the Commission.
5. **Bidding Process:** The Transmission Service Provider shall be selected through tariff based competitive bidding process for the Project based on meeting stipulated Qualification Requirements prescribed in Clause 2.1 of Section 2 of RFP and the lowest Quoted Transmission Charges discovered from Final Offers quoted during the e-reverse bidding. The selection of the TSP shall be subject to it obtaining Transmission License from the Commission, which, after expiry, may be further extended by such period as deemed appropriate by the Commission under powers vested with it to amend the conditions of the Transmission License.

The entire bidding process shall be conducted on electronic platform created by MSTC Limited.

The Bid shall be a single stage two envelope bid comprising the Technical Bid and the Financial Bid. The Bidders shall submit the Bid online through the electronic bidding platform. In addition to the online submission, the Bidder with lowest Final Offer will be required to submit original hard copies of Annexure 3, Annexure 4 (if applicable), Annexure 6 (if applicable) and Annexure 14 before issuance of LoI. There shall be no physical submission of the Financial Bid.

The Technical Bid shall be opened first and the Financial Bid of only the bidder who have qualified in the Technical Bid shall be opened. The Financial Bid will comprise of two rounds. In the first round the Initial Offer of the responsive bids would be opened and Quoted Transmission Charges of Initial Offer shall be ranked on the basis of ascending order. The Bidders, in the first fifty per cent of the ranking (with any fraction rounded off to higher integer) or four Bidders, whichever is higher, shall qualify for participating in the electronic reverse auction stage and submit their Final Offer.

6. The objective of the bidding process is to select a Successful Bidder pursuant to this RFP, who shall acquire one hundred percent (100%) of the equity shares of Kallam Transco Limited along with all its related assets and liabilities as per the provisions of the Share Purchase Agreement, at the Acquisition Price to be intimated by the BPC, twenty (20) days prior to the Bid Deadline.

The Kallam Transco Limited, of which one hundred percent (100%) equity shares will be acquired by the Selected Bidder, shall be responsible as the TSP, for ensuring that it undertakes ownership, financing, development, design, engineering, procurement, construction, commissioning, operation and maintenance of the Project, and to provide Transmission Service as per the terms of the RFP Project Documents.

The TSP shall ensure transfer of all project assets along with substation land, right of way and clearances to CTU or its successors or an agency as decided by the Central Government after 35 years from COD of project at zero cost and free from any encumbrance and

liability. The transfer shall be completed within 90 days after 35 years from COD of project failing which CTU shall be entitled to take over the project assets Suo moto.

7. **Commencement of Transmission Service:** The Bidder shall have to commence Transmission Service in accordance with the provisions of the Transmission Service Agreement.
8. **Transmission Charges:** The Transmission Charges shall be payable by the Designated ISTS Customers in Indian Rupees through the CTU as per Central Electricity Regulatory Commission (Sharing of Inter-State Transmission Charges and Losses) Regulations as amended from time to time. Bidders shall quote the Transmission Charges as per the pre-specified structure, as mentioned in the RFP.
9. **Issue of RFP document:** The detailed terms and conditions for qualification and selection of the Transmission Service Provider for the Project and for submission of Bid are indicated in the RFP document. All those interested in purchasing the RFP document may respond in writing to Chief Executive Officer, pshariharan@recpdcl.in & tbc@recpdcl.in at the address given in para 12 below with a non-refundable fee of Rs. 5,00,000/- (Rupees Five Lakh Only) or US\$ 7,000 (US Dollars Seven Thousand Only) plus GST @18%, to be paid latest by 14.12.2023 via electronic transfer to the following Bank Account:

Bank Name, Address & Branch	IDFC First Bank Limited Birla Towers, 4th Floor East Tower & LGF West Tower, Barakhamba Road, New Delhi – 110001
Bank Account Name	REC Power Development & Consultancy Limited
Bank Account No	10000697415
Bank IFSC Code No	IDFB0020101

Immediately after issuance of RFP document, the Bidder shall submit the Pre-Award Integrity Pact in the format as prescribed in Annexure B, which shall be applicable for and during the bidding process, duly signed on each page by any whole-time Director / Authorized Signatory, duly witnessed by two persons, and shall be submitted by the Bidder in two (2) originals in a separate envelope, duly superscripted with Pre-Award Integrity Pact. The Bidder shall submit the Pre-Award Integrity Pact on non-judicial stamp paper of Rs. 100/- each duly purchased from the National Capital Territory of Delhi. In case the Bidder is in a consortium, the Pre-Award Integrity Pact shall be signed and submitted by each member of the Consortium separately.

The RFP document shall be issued to the Bidders on any working day from 13.10.2023 to 14.12.2023 between 1030 hours (IST) to 1600 hours (IST). The BPC, on written request and against payment of the above mentioned fee by any Bidder shall promptly dispatch the RFP document to such Bidder by registered mail/ air mail. BPC shall, under no circumstances, be held responsible for late delivery or loss of documents so mailed.

10. **Receipt and opening of Bid:** The Bid must be uploaded online through the electronic bidding platform on or before 1400 hours (IST) on 15.12.2023 Technical Bid will be opened by the Bid Opening Committee on the same day at 1430 hours (IST) in the office of Central Electricity Authority, in the online presence of Bidders' representatives who wish to attend. If the Bid Deadline is a public holiday at the place of submission of Bid, it shall be opened on the next working day at the same time and venue. In addition to the online submission, the Bidder with lowest Final Offer will be required to submit original hard copies of Annexure 3, Annexure 4 (if applicable), Annexure 6 (if applicable) and Annexure 14 before issuance of LoI. Bidders meeting the Qualification Requirements, subject to evaluation as

specified in Clause 3.2 to 3.4 shall be declared as “Qualified Bidders” and eligible for opening of Initial Offer.

11. The RFP document is not transferable. BPC reserves the right to reject all Bid and/or annul the process of tariff based competitive bidding for selection of Bidder as TSP to execute the Project without assigning any reason. BPC shall not bear any liability, whatsoever, in this regard.

12. **Nodal person for enquiries and clarifications**

All correspondence and clarification in respect of RFP document shall be addressed to:

Chief Executive Officer,
REC Power Development and Consultancy Limited
(A wholly owned subsidiary of REC Limited)
REC Corporate Head Quarter,
D Block, Plot No. I – 4,
Sec – 29 Gurugram – 122 001
Email: pshariharan@recpdcl.in & tbc@recpdcl.in

DISCLAIMER

1. This Request for Proposal (RFP) document is not an agreement or offer by the BPC to the prospective Bidders or to any other party. The purpose of this RFP document is to provide interested parties with information to assist the formulation of their Bid. The RFP document is based on material and information available in public domain.
2. This RFP, along with its Annexure, is not transferable and the information contained therein are to be used only by the person to whom it is issued. It may not be copied or distributed by the recipient to third parties (other than in confidence to the recipient's professional advisors). In the event that the recipient does not continue with its involvement in the Project in accordance with this RFP, this RFP must be kept confidential.
3. While this RFP has been prepared in good faith, neither the BPC nor its employees or advisors/consultants make any representation or warranty expressed or implied as to the accuracy, reliability or completeness of the information contained in this RFP. The Bidders shall satisfy themselves, on receipt of the RFP document, that the RFP document is complete in all respects. Intimation of any discrepancy shall be given to this office immediately. If no intimation is received from any Bidder within ten (10) days from the date of issue of this RFP document on or before the date & time mentioned in this RFP, it shall be considered that the issued document, complete in all respects, has been received by the Bidders.

This bidding process is in accordance with the Bidding Guidelines issued by Ministry of Power, Government of India under Section 63 of the Electricity Act, 2003. Revisions or amendments in these Bidding Guidelines may cause the BPC to modify, amend or supplement this RFP document, including the RFP Project Documents to be in conformance with the Bidding Guidelines.

4. This RFP document includes statements, which reflect various assumptions arrived at by BPC in order to give a reflection of current status in the RFP. These assumptions should not be entirely relied upon by Bidders in making their own assessments. This RFP document does not purport to contain all the information each Bidder may require and may not be appropriate for all persons. It is not possible for BPC to consider the investment objectives, financial situation and particular needs of each party who reads or uses this RFP document. Certain Bidders may have a better knowledge of the Project than the others. Each Bidder should conduct its own investigations and analysis and should check the accuracy, reliability and completeness of the information in this RFP document and obtain independent advice from appropriate sources.
5. Neither BPC nor their employees or consultants make any representation or warranty as to the accuracy, reliability or completeness of the information in this RFP document.
6. Neither BPC, its employees nor its consultants will have any liability to any Bidder or any other person under the law of contract, tort, the principles of restitution or unjust enrichment or otherwise for any loss, expense or damage which may arise from or be incurred or suffered in connection with anything contained in this RFP document, any matter deemed to form part of this RFP document, the award of the Project, the information supplied by or on behalf of BPC or its employees, any consultants or otherwise arising in any way from the qualification process for the said Project.
7. By participating in the bidding process, each of the Bidder shall have acknowledged and accepted that it has not been induced to enter into such agreement by any representation or warranty, expressed or implied, or relied upon any such representation or warranty by or

on behalf of BPC or any person working in the bidding process.

8. BPC may in its absolute discretion, but without being under any obligation to do so, update, amend or supplement this RFP document. Such updations, amendments or supplements, if any, will however be circulated to the Bidders not later than 15 days prior to the last date for submission of Bid.
9. Each Bidder unconditionally agrees, understands and accepts that the BPC reserves the rights to accept or reject any or all Bids without giving any reason. Neither the BPC nor its advisers shall entertain any claim of any nature, whatsoever, including without limitations, any claim seeking expenses in relation to the preparation of Bids.
10. This RFP may be withdrawn or cancelled by the BPC at any time without assigning any reasons thereof. BPC further reserves the right, at its complete discretion to reject any or all of the Bids without assigning any reasons whatsoever.

INDEX

SECTION	CONTENTS	PAGE NO.
	DEFINITIONS	11
1.	INTRODUCTION	16
2.	INFORMATION AND INSTRUCTIONS FOR BIDDERS	22
3.	EVALUATION OF THE TECHNICAL AND FINANCIAL BID	48
4.	ANNEXURES FOR BID	54
	ANNEXURES	
1	Format for the Covering Letter	56
2	Format for Letter of Consent from Consortium Members	59
3	Format for evidence of authorized signatory's authority (Power of Attorney)	61
4	Format for Power of Attorney to be provided by each of the other members of the Consortium in favor of the Lead Member	63
5	Format for Bidder's composition and ownership structure and Format for Authorization	65
6	Format for Consortium Agreement	68
7A	Format for Qualification Requirement – Net worth	73
7B	Format for Technical Requirement	76
7C	Format for Technical and Financial Requirement – Relationship & Equity Shareholding	79
7D	Format for Additional Information for verification of Financial and Technical Capabilities of Bidders	81
8	Format for Undertaking and Details of Equity Investment	84
9	Format for Authorization from Parent / Affiliate of Bidding Company / Member of Bidding Consortium whose technical / financial capability has been used by the Bidding Company / Member of Bidding Consortium.	88
10	Format for Undertaking by Technically/Financially Evaluated Entity/Ultimate Parent Company	90
11	Format for Board Resolution	92
11A	Illustration for Applicable Board Resolution Requirements under Clause 2.5.2	95
12	Format for illustration of Affiliates	97
13	Format for disclosure	98
14	Format For Bid Bond	99
14 A	Format for Bid Security Declaration	101

SECTION	CONTENTS	PAGE NO.
15	Format for Contract Performance Guarantee	102
16	Format for Checklist for Technical Bid Submission Requirements	104
17	List of Banks	107
18	Grid Map of the Project	108
19	Format for Clarifications / Amendments on the RFP / RFP Project Documents	109
20	Formats For RFP Project Documents	110
21	Format For Financial Bid	111
22	Format of Affidavit	112
	Annexure A	114
	Annexure-B	116
	Annexure-C	123

DEFINITIONS

Any capitalized term, used but not defined in this RFP, shall have the meaning ascribed to such term in the RFP Project Documents, or the Bidding Guidelines, in that order. In absence of availability of definitions in the foregoing references, the capitalized terms shall be interpreted in accordance with the Electricity Act 2003, Grid Code or any other relevant electricity law, rule or regulation prevalent in India, as amended or re-enacted from time to time, in that order.

The following terms are defined for use in this RFP:

"Acquisition Price" shall have the same meaning as defined in the Share Purchase Agreement;

"Affiliate" shall mean a company that either directly or indirectly

- i. controls or
- ii. is controlled by or
- iii. is under common control with

a Bidding Company (in the case of a single company) or a Member (in the case of a Consortium) and **"control"** means ownership by one entity of at least twenty six percent (26%) of the voting rights of the entity. As an illustration a chart is annexed hereto as Annexure – 12;

"Bid" shall mean Technical Bid and Financial Bid (Initial Offer and Final Offer) submitted by the Bidder, in response to this RFP, in accordance with the terms and conditions thereof;

"Bidder" shall mean either a single company (including its permitted successors and legal assigns) or a Consortium of companies (including its permitted successors and legal assigns) submitting a Bid in response to this RFP. Any reference to the Bidder includes Bidding Company, Bidding Consortium/ Consortium, Member in a Bidding Consortium and Lead Member of the Bidding Consortium jointly and severally, as the context may require;

"Bidding Company" shall refer to such single company (including its permitted successors and legal assigns) that has submitted a Bid for the Project;

"Bidding Consortium/ Consortium" shall refer to a group of companies (including their permitted successors and legal assigns) that has collectively submitted a Bid for the Project;

"Bidding Guidelines" shall mean the "Tariff Based Competitive-Bidding Guidelines for Transmission Service" and "Guidelines for Encouraging Competition in Development of Transmission Projects" issued by Government of India, Ministry of Power under Section – 63 of Electricity Act as amended from time to time;

"Bid Bond" shall mean the unconditional and irrevocable bank guarantee for Rupees One Crore twenty Lakh Only (Rs. 1.20 Crore), to be submitted along with the Technical Bid by the Bidder under Clause 2.11 of this RFP, as per the format prescribed in Annexure 14;

"Bid Deadline" shall mean the last date and time for submission of online Bid in response to this RFP, specified in Clause 2.7.1;

"Bid Process Coordinator or BPC" shall mean a person or its authorized representative as notified by the Government of India, responsible for carrying out the process for selection of Bidder who will acquire Transmission Service Provider;

~~“Bid Security Declaration” shall mean the declaration to be submitted along with the Technical Bid by the Bidder in lieu of the Bid Bond, as per the format prescribed in Annexure 14A;~~

"CEA" shall mean the Central Electricity Authority constituted under Section - 70 of the Electricity Act;

“Commission” or “CERC” shall mean the Central Electricity Regulatory Commission of India constituted under Section-76 of The Electricity Act, 2003 and any successors and assigns;

“Conflict of Interest” A Bidder shall be considered to be in a Conflict of Interest with one or more Bidders in the same bidding process if they have a relationship with each other, directly or through a common company, that puts them in a position to have access to information about or influence the Bid of another Bidder.

Provided that if two or more bidders in the bidding process have formed a Joint Venture Company or Consortium to execute another project, the Bidders will not be considered to have Conflict of Interest;

"Commercial Operation Date (COD)" shall mean the date as per Article 6.2 of the Transmission Service Agreement;

“Consents, Clearances, Permits” shall mean all authorizations, licenses, approvals, registrations, permits, waivers, privileges, acknowledgements, agreements, or concessions required to be obtained from or provided by any concerned authority for the development, execution and performance of Project including without any limitation on the construction, ownership, operation and maintenance of the transmission lines and/or sub-stations;

"Contract Performance Guarantee" shall have the meaning as per Clause 2.12 of this RFP;

"Contract Year" shall mean the period beginning on the Scheduled COD, and ending on the immediately succeeding March 31 and thereafter each period of 12 months beginning on April 1 and ending on March 31 provided that:

- (i) the last Contract Year shall end on the last day of the term of the Transmission Service Agreement;

“Infrastructure sector” shall mean such sectors notified by Department of Economic Affairs in its Gazette Notification no. 13/1/2017-INF dated 14th November, 2017 and as amended from time to time;

"CTU/Central Transmission Utility" shall have same meaning as defined in the Electricity Act, 2003;

“Designated ISTS Customers” or “DICs” shall have the meaning as ascribed in Regulation 2(l) of Central Electricity Regulatory Commission (Sharing of inter-State Transmission Charges and Losses) Regulation 2020 and as amended or modified from time to time;

"Effective Date" shall have the meaning as ascribed thereto in the Transmission Service Agreement;

"Element" shall mean each Transmission Line or each circuit of the Transmission Lines (where there are more than one circuit) or each bay of the Sub-station or switching station or HVDC terminal or inverter station of the Project, including ICTs, Reactors, SVC, FSC, etc. forming part of the ISTS which will be owned, operated and maintained by the concerned ISTS Licensee, and which may have a separate scheduled COD as per Schedule 2 of the Transmission Service Agreement and may have a separate percentage for recovery of Transmission Charges on achieving COD as per Schedule 5 of the Transmission Service Agreement;

"Final Offer" shall mean the Quoted Transmission Charges, required to be submitted as part of the Financial Bid on the electronic bidding platform during the e-reverse bidding stage. In case, no Final Offer is received during the e-reverse bidding stage then the lowest "Initial Offer" shall be deemed to be the Final Offer;

"Financial Bid" shall mean the Initial Offer and Final Offer, containing the Bidder's Quoted Transmission Charges, as per the format at Annexure – 21 of this RFP;

"Financially Evaluated Entity" shall mean the company which has been evaluated for the satisfaction of the financial requirement set forth in Clause 2.1.3 hereof;

"Government" shall mean the Central Government;

"Grid Code" / "IEGC" or "State Grid Code" shall mean the Grid Code specified by the Central Commission under clause (h) of sub-section (1) of Section 79 of the Electricity Act and/or the State Grid Code as specified by the concerned State Commission referred under clause (h) of sub-section (1) of Section 86 of the Electricity Act as applicable;

"Initial Offer" shall mean the Quoted Transmission Charges, required to be submitted as part of the Financial Bid on the electronic bidding platform along with the Technical Bid;

"Inter State Generating Station" or "ISGS" shall mean a Central / other generating station in which two or more states have shares and whose scheduling is to be coordinated by the Regional Load Despatch Centre;

"Inter-State Transmission System" shall have same meaning as defined in the Electricity Act, 2003;

"Lead Member of the Bidding Consortium" or "Lead Member" shall mean a company who commits at least twenty six percent (26%) equity stake in the Project, meets the technical requirement as per Clause 2.1.2 and so designated by other Member(s) in Bidding Consortium;

"Letter of Intent" or "LoI" shall mean the letter to be issued by the BPC to the Bidder, who has been identified as the selected bidder, for award of the Project to such Bidder;

"Member in a Bidding Consortium/Member" shall mean each company in the Bidding Consortium;

"MOP" shall mean the Ministry of Power, Government of India;

"MOEF" shall mean the Ministry of the Environment and Forests, Government of India;

"National Committee on Transmission" shall mean the committee constituted by the Ministry of Power, Government of India in terms of the "Guidelines for Encouraging Competition in Development of Transmission Projects", as notified from time to time;

“Nodal Agency” shall mean CTU, which shall execute and implement the Transmission Service Agreement (TSA);

Provided that while taking major decisions, CTU shall consult CEA on technical matters and any other matter it feels necessary.

“Parent Company” shall mean an entity that holds at least twenty six percent (26%) of the paid - up equity capital directly or indirectly in the Bidding Company or in the Member in a Bidding Consortium, as the case may be;

“Qualification Requirements” shall mean the qualification requirements as set forth in Section-2, Clause 2.1 of this RFP;

“Quoted Transmission Charges” shall mean the quoted single annual Transmission Charges submitted online through the electronic bidding platform by the Bidder as part of its Financial Bid as per the format in Annexure – 21 of this RFP;

“RFP” shall mean Request for Proposal document along with all schedules, formats, annexure and RFP Project Documents attached hereto, issued by BPC for tariff based competitive bidding process for selection of bidder who will acquire the TSP through e-reverse bidding to execute the Project, and shall include any modifications, amendments or alterations or clarifications thereto;

“RFP Project Documents” shall mean the following documents to be entered into in respect of the Project, by the parties to the respective agreements:

- a. Transmission Service Agreement (TSA),
- b. Share Purchase Agreement,
- c. Agreement(s) required, if any, under Central Electricity Regulatory Commission (Sharing of Inter-State Transmission Charges and Losses) Regulations as amended from time to time and
- d. Any other agreement, as may be required;

"Scheduled COD" shall have the meaning as ascribed hereto in Clause 2.6 of this RFP;

“Statutory Auditor” shall mean the auditor appointed under the provisions of the Companies Act, 1956 / Companies Act, 2013 (as the case may be) or under the provisions of any other applicable governing law;

"Share Purchase Agreement" shall mean the agreement amongst REC Power Development and Consultancy Limited, Kallam Transco Limited and the Successful Bidder for the purchase of one hundred (100%) per cent of the shareholding of the Kallam Transco Limited for the Acquisition Price, by the Successful Bidder on the terms and conditions as contained therein;

"Successful Bidder" or "Selected Bidder" shall mean the Bidder selected pursuant to this RFP to acquire one hundred percent (100%) equity shares of Kallam Transco Limited, along with all its related assets and liabilities, which will be responsible as the TSP to establish the Project on build, own, operate and transfer basis as per the terms of the Transmission Service Agreement and other RFP Project Documents;

"Survey Report" shall mean the report containing initial information regarding the Project and other details provided as per the provisions of Clause 1.6.2.1.1 of this RFP;

"Technical Bid" shall mean the bid submitted online through the electronic bidding platform, containing the documents as listed out in Clause 2.5.2 of this RFP;

"Technically Evaluated Entity" shall mean the company which has been evaluated for the satisfaction of the technical requirement set forth in Clause 2.1.2 hereof;

"Transmission Charges" shall mean the Final Offer quoted by Selected Bidder and adopted by the Commission, and as computed in terms of the provisions of Schedule 4 of the TSA, payable to the ISTS Licensee by the Designated ISTS Customers, and collected / disbursed by the CTU, as per Central Electricity Regulatory Commission (Sharing of Inter-State Transmission Charges and Losses) Regulations as amended from time to time;

"Transmission License" shall mean the license granted by the Commission in terms of the relevant regulations for grant of such license issued under the Electricity Act, 2003;

"Transmission Service Agreement" or **"TSA"** shall mean the agreement entered into between Nodal Agency and the TSP, pursuant to which the TSP shall build, own, operate and transfer the Project and make available the assets of the Project on a commercial basis;

"Transmission Service Provider" or "TSP" shall mean Kallam Transco Limited which has executed the Transmission Service Agreement and which shall be acquired by the Selected Bidder;

"Ultimate Parent Company" shall mean an entity which owns at least twenty six percent (26%) equity in the Bidding Company or Member of a Consortium, (as the case may be) and in the Technically Evaluated Entity and/or Financially Evaluated Entity (as the case may be) and such Bidding Company or Member of a Consortium, (as the case may be) and the Technically Evaluated Entity and/or Financially Evaluated Entity (as the case may be) shall be under the direct control or indirectly under the common control of such entity.

SECTION – 1

INTRODUCTION

SECTION 1

1. INTRODUCTION

- 1.1 Central Electricity Authority (CEA), Government of India vide its notification no 560 [F No. CEA-PS-12-13/3/2022-PSPA-II Division] dated 10.08.2023 has notified REC Power Development and Consultancy Limited (RECPDCL) to be the Bid Process Coordinator (BPC) for the purpose of selection of Bidder as Transmission Service Provider (TSP) to establish Inter-State transmission system for “**Western Region Network Expansion scheme in Kallam area of Maharashtra**” through tariff based competitive bidding process.

The BPC hereby invites Bids from all prospective Bidders in accordance with this Request for Proposal (RFP) to select prospective Transmission Service Provider (TSP) in accordance with the “Tariff Based Competitive-Bidding Guidelines for Transmission Service” and “Guidelines for Encouraging Competition in Development of Transmission Projects” issued by Government of India, Ministry of Power under Section – 63 of the Electricity Act. The BPC shall select the Bidder having the prescribed technical and financial capability to become TSP and be responsible for establishing the Project in the state(s) of Himachal Pradesh. The TSP will make the Project available against payment of Transmission Charges, as adopted by the Commission, payable to the TSP, as per Central Electricity Regulatory Commission (Sharing of Inter-State Transmission Charges and Losses) Regulations as amended from time to time.

- 1.2 The TSP will be required to establish the following Inter State Transmission System for **Western Region Network Expansion scheme in Kallam area of Maharashtra** (hereinafter referred to as ‘Project’) on build, own, operate and transfer basis, and to provide transmission service.

Sl. No.	Scope of the Transmission Scheme	Scheduled COD in months from Effective Date
1	LILO of both circuits of Parli(M) – Karjat(M)/Lonikand-II (M) 400 kV D/c line (twin moose) at Kallam PS	18 months
2	4 Nos. 400 kV line bays at Kallam PS for LILO of both circuits of Parli(M) – Karjat(M)/Lonikand-II(M) 400 kV D/c line (twin moose) at Kallam PS <ul style="list-style-type: none"> 400 kV line bays (AIS) – 4 Nos. (for Kallam PS end) 	
3	63 MVAR, 420 kV switchable line reactor (with NGR bypassing arrangement) on each ckt at Kallam PS end of Karjat – Kallam 400 kV D/c line (~140km) <ul style="list-style-type: none"> 63 MVAR, 420 kV switchable line reactor including Switching equipment - 2 Nos. (at Kallam end) 	

Note:

- TSP of Kallam PS (Kallam Transmission Ltd.) shall provide requisite space at Kallam PS for above scope of work.
- The 50 MVAR fixed line reactors on each ckt at Parli (M) end of Kallam – Parli (M) 400 kV D/c line shall be converted into switchable line reactors (with NGR bypass arrangement & provision of inter-tripping scheme to trip the line reactors along with the

main line breakers) by MSETCL in matching time-frame of the above scheme. MSETCL vide email dated 08.06.2023 has informed that conversion of fixed 50 MVAR line reactor at 400 kV Parli (M) (Girwali) end into switchable reactor is feasible.

1.3 Project Description

Govt. of India has set a target for establishing 500 GW capacity from non-fossil energy sources by 2030. In this direction, 2GW capacity has been identified at Kallam PS. Transmission System for evacuation of power from RE Projects in Osmanabad area (1 GW) in Maharashtra is presently under implementation by Kallam Transmission Ltd. which is expected by Oct'23. Further, augmentation of transformation capacity at Kallam PS by 2x500 MVA, 400/220 kV ICTs (3rd & 4th) along with 220kV bays for RE interconnection is also under implementation for enabling interconnection of additional 1GW at 220kV level of Kallam PS (expected by May'24).

Additional connectivity has also been granted to M/ s Torrent at 400kV level (1 no. bay) and hence there is cumulative requirement of evacuation of about 3.25GW (2GW at 220kV level and 1.25GW at 400kV level) from Kallam PS.

The subject Transmission system shall enable evacuation of power beyond 2GW at Kallam PS (upto 3.25GW), by alleviating constraints in the area, using Renewable energy sources and is expected to play a significant role in fulfilling India's vision of 500 GW of non-fossil generation capacity by 2030.

The subject scheme includes LILO of both circuits of Parli(M) – Karjat(M)/Lonikand-II (M) 400 kV D/c line (twin moose) at Kallam PS along with 63 MVAR, 420 kV switchable line reactor (with NGR bypassing arrangement) on each ckt at Kallam PS end of Karjat – Kallam 400 kV D/c line. The scheme will facilitate integration of 1.25GW power beyond 2GW at Kallam PS (i.e. upto 3.25GW).

The subject Transmission system was deliberated and approved in the 14th NCT meeting held on 09.06.2023. National Committee on Transmission vide Gazette notification dated 10.08.2023 has appointed RECPDCL as BPC for implementation of the subject transmission scheme through TBCB route.

1.4 Transmission Grid Map

Transmission Grid Map indicating the location of the Project is enclosed as Annexure 18 of this RFP for information and reference of the Bidders.

1.5 The objective of the bidding process is to select a Successful Bidder pursuant to this RFP, who shall acquire one hundred percent (100%) of the equity shares of Kallam Transco Limited along with all its related assets and liabilities as per the provisions of the Share Purchase Agreement, at the Acquisition Price to be intimated by the BPC, twenty (20) days prior to the Bid Deadline.

The Kallam Transco Limited, of which one hundred percent (100%) equity shares will be acquired by the Selected Bidder, shall be responsible as the TSP, for ensuring that it undertakes ownership, financing, development, design, engineering, procurement,

construction, commissioning, operation and maintenance of the Project, and to provide Transmission Service as per the terms of the RFP Project Documents.

The TSP shall ensure transfer of all project assets along with substation land, right of way and clearances to CTU or its successors or an agency as decided by the Central Government after 35 years from COD of project at zero cost and free from any encumbrance and liability. The transfer shall be completed within 90 days after 35 years from COD of project failing which CTU shall be entitled to take over the project assets Suo moto.

1.6 Brief Scope of Work

1.6.1 Scope of Transmission Service Provider

The TSP's scope of work for the Project shall comprise, but not necessarily be limited to the following:

- 1.6.1.1 Establishment, operation and maintenance of the Project on build, own, operate and transfer basis and completion of all the activities for the Project, including survey, detailed project report formulation, arranging finance, project management, necessary Consents, Clearances and Permits (way leave, environment & forest, civil aviation, railway/ road/river/canal/power crossing/PTCC, etc.), land compensation, design, engineering, equipment, material, construction, erection, testing & commissioning. Further, the actual location of Greenfield substations (Switching Stations or HVDC Terminal or Inverter Stations) for a generation pooling substation and for load serving substations in the scope of TSP shall not be beyond 3 Km radius of the location proposed by the BPC in the survey report. However, actual location of any Greenfield Intermediate Substations in the scope of TSP shall not be beyond 10 Km radius of the location proposed by the BPC in the Survey Report.
- 1.6.1.2 The TSP shall ensure that design, construction and testing of all equipment, facilities, components and systems of the Project shall be in accordance with Transmission Service Agreement and applicable Rules/ Regulations, Orders and Guidelines issued by the Central Government.
- 1.6.1.3 The TSP shall ensure timely completion of entire scope of Project in all respects and its operation and maintenance, as shall be specified in the RFP documents.
- 1.6.1.4 The TSP shall seek Transmission License from the Commission, as per the provisions of the Electricity Act and regulations made thereunder.
- 1.6.1.5 The TSP shall seek approval under Section 164 of Electricity Act, from CEA after acquisition of Kallam Transco Limited. The approval shall be granted by CEA generally within 30 days but in no case later than 45 days from the date of receipt of application (complete in all aspects).

1.6.2 Scope of Bid Process Coordinator (BPC)

BPC's scope of work is briefly outlined hereunder:

- 1.6.2.1 The BPC has initiated development of the Project and shall be responsible for the tasks in this regard as specified hereunder:

1. Provide to the Bidders a Survey Report for the Project at least forty five (45) days prior to the Bid Deadline. The Survey Report shall include the suggested route with approximate route length, type of terrain likely to be encountered and its likely implication in terms of Right of Way (ROW), statutory clearances, location of substations or converter stations and land area to be acquired for the substation or converter station.
2. To obtain approval for laying of overhead transmission lines under Section 68 of Electricity Act, from the Government at least twenty (20) days prior to Bid Deadline.
3. To initiate acquisition of land for location specific substations, switching stations or HVDC terminal or inverter stations, if required.
4. To initiate process of seeking forest clearance, if required
5. The BPC shall intimate to the Bidders, the Acquisition Price payable by the Selected Bidder to the REC Power Development and Consultancy Limited for the acquisition of one hundred percent (100%) of the equity shareholding of Kallam Transco Limited, along with all its related assets and liabilities at least twenty (20) days prior to the Bid Deadline.
6. The BPC shall ensure issuance of all finalized RFP Project Documents, at least fifteen (15) days prior to the Bid Deadline.

Provided that for any delay in meeting the above obligations of the BPC within the specified time period above, the Bid Deadline as per Clause 2.7.1 shall be extended on a day for day basis.

- 1.6.2.2 The details and documents as may be obtained by the BPC/ project specific SPV in relation to the Project shall be handed over to the TSP on an as-is-where-is basis, so that it may take further actions to obtain Consents, Clearances and Permits.
- 1.7 All costs (including direct and indirect) incurred by the BPC/ project specific SPV in connection with the activities concerning the Project shall be recovered from the TSP, which shall be included in the Acquisition Price.
- 1.8 The Project is required to be completed progressively in accordance with the schedule prescribed in this RFP.
- 1.9 A company under the Companies Act, 2013 by the Kallam Transco Limited has been incorporated to initiate the activities for execution of the Project. The said company shall be acquired by the successful Bidder as per terms and conditions as may be prescribed in RFP.
- 1.10 The Ministry of Power and the appropriate state government(s) shall provide their support to the TSP, on best endeavor basis, in enabling the TSP to develop the Project.
- 1.11 All Bidders are required to submit their Bid in accordance with the instructions set forth in this RFP.
- 1.12 Once the Successful Bidder is selected, the details and documents as may be obtained by the BPC/ project specific SPV in relation to the Project, shall be handed over to the Successful Bidder on as is where basis, so that it may take further actions to obtain all necessary Consents, Clearances and Permits and the TSP shall not be entitled for any

extensions in the Scheduled COD of the Project except as provided for in the TSA.

- 1.13 The assets of the Project shall be made available on a commercial basis as per the terms and conditions of the Transmission Service Agreement and Central Electricity Regulatory Commission (Sharing of Inter-State Transmission Charges and Losses) Regulations as amended from time to time.

SECTION - 2

INFORMATION AND INSTRUCTIONS FOR BIDDERS

SECTION – 2**2. INFORMATION AND INSTRUCTIONS FOR BIDDERS****2.1 Qualification Requirements**

- 2.1.1 The Bidder should be a company duly incorporated under the relevant laws (Bidding Company) or a Consortium of companies (Bidding Consortium) with one of the companies acting as the Lead Member of the Bidding Consortium. The Bidder shall be selected on meeting the Qualification Requirements specified in Section 2 of this RFP, as demonstrated by the Bidder's Technical Bid and the lowest Quoted Transmission Charges discovered from Final Offers quoted during the e-reverse bidding. A Bidding Consortium can participate in the bidding process for the Project if any Member of the Consortium has purchased the RFP document for such Project. Bidder who agree and undertake to procure the products associated with the Transmission System as per provisions of Public Procurement (Preference to Make in India) orders issued by Ministry of Power vide orders No. 11/5/2018 - Coord. dated 28.07.2020 for transmission sector, as amended from time to time read with Department for Promotion of Industry and Internal Trade (DPIIT) orders in this regard, shall be eligible hereunder. Further, it is clarified that Procuring Entity as defined in orders shall deemed to have included Selected Bidder and/ or TSP.

Besides, Department of Expenditure, Ministry of Finance vide Order (Public Procurement No 1) bearing File No. 6/18/2019-PPD dated 23.07.2020, Order (Public Procurement No 2) bearing File No. 6/18/2019-PPD dated 23.07.2020 and Order (Public Procurement No. 3) bearing File No. 6/18/2019-PPD, dated 24.07.2020, as amended from time to time, have issued directions regarding public procurement from a bidder of a country, which shares land border with India are also applicable.

2.1.2 Technical requirement to be met by the Bidding Company or Lead Member of Bidding Consortium

The Bidder must fulfill any one of the following technical requirements:

- (i) Experience of development of projects in the Infrastructure Sector in the last five (5) years with aggregate capital expenditure of not less than **Rs. 500 Crore** or equivalent USD (calculated as per provisions in Clause 3.4.1). However, the capital expenditure of each project shall not be less than **Rs. 100 Crore** or equivalent USD (calculated as per provisions in Clause 3.4.1).

For this purpose, capital expenditure incurred on projects that have been commissioned/completed at least seven (7) days prior to Bid Deadline shall be considered. The capital expenditure discussed above shall be as capitalized and reflected in the audited books of accounts of the Technically Evaluated Entity. In case a clearly identifiable part of a project has been put into commercial operation, the capital expenditure on such part of the project shall be considered. The Technically Evaluated Entity must have either executed such projects itself or must have held directly or indirectly at least twenty six percent (26%) of the shareholding in the company that has executed the project(s) from the date of financial closure of the project(s) till the time of commissioning/completion of such project(s).

OR

- (ii) Experience in construction of project in infrastructure sector: The Technically Evaluated Entity should have received aggregate payments not less than Rs. **500 Crore** or equivalent USD (calculated as per provisions in Clause 3.4.1) from its client(s) for construction works fully completed during the last 5(five) financial years. However, the payment received from each project shall not be less than Rs. **100 Crore** or equivalent USD (calculated as per provisions in Clause 3.4.1).

For this purpose, payments received on projects that have been commissioned/completed at least seven (7) days prior to Bid Deadline shall be considered. Further only the payments (gross) actually received, during such 5 (five) financial years shall qualify for purposes of computing the technical capacity. For the avoidance of doubt, construction works shall not include cost of land, supply of goods or equipment except when such goods or equipment form part of a turn-key construction contract/EPC contract for the project. Further, in cases where different individual contracts are signed between same entities for the same project, the cumulative payments received under such individual contracts shall be considered for meeting the qualification requirement.

The Technically Evaluated Entity may be the Bidding Company or the Lead Member of a Consortium or an Affiliate or Parent of such Bidding Company or the Lead Member, as the case may be.

Bidders shall furnish documentary evidence duly certified by authorized signatory of the Bidder who has been issued Power of Attorney in support of their technical capability as defined in Clause 2.1.2 of this RFP.

2.1.3 Financial requirement to be met by the Bidding Company/Bidding Consortium

2.1.3.1 The Bidder must fulfill following financial requirements:

A. Networth:

Networth should be not less than Rs. **250 Crore** or equivalent USD (calculated as per provisions in Clause 3.4.1) computed as the Networth based on unconsolidated audited annual accounts (refer to Note below) of any of the last three (3) financial years as provided in Clause 2.2.3, immediately preceding the Bid Deadline. Also, the Networth of any of the last three (3) financial years should not be negative.

Note: Audited consolidated annual accounts of the Bidder may be used for the purpose of financial criteria provided the Bidder has at least 26% equity in each company whose accounts are merged in the audited consolidated accounts and provided further that the financial capability of such companies (of which accounts are being merged in the consolidated accounts) shall not be considered again for the purpose of evaluation of the Technical Bid. Bidders shall furnish prescribed Annexure 7 (A) duly certified by authorized signatory of the Bidder who has been issued Power of Attorney and the Statutory Auditor and separate computation sheet for Networth duly certified by Statutory Auditor in support of their financial capability as defined in Clause 2.1.3 of this RFP.

2.1.3.2 The Networth shall be computed in the following manner by the Bidder:

A. Networth

=	Equity share capital
Add:	Reserves
Subtract:	Revaluation Reserves
Subtract:	Intangible Assets
Subtract:	Miscellaneous expenditures to the extent not written off and carry forward losses

2.1.3.3 If the Technical Bid is submitted by a Bidding Consortium the financial requirement shall be met individually and collectively by all the Members in the Bidding Consortium. The financial requirement to be met by each Member of the Bidding Consortium shall be computed in proportion to the equity commitment made by each of them for investment in the Project.

2.1.4 The Bidder may seek qualification on the basis of technical and financial capability of its Parent and/ or its Affiliate(s) for the purpose of meeting the Qualification Requirements. However, in the case of the Bidder being a Consortium, the Lead Member has to meet the technical requirement on its own or by seeking the technical capability of its Parent and/or its Affiliate(s). Authorization for use of such technical or financial capability shall have to be provided from its Parent and/or Affiliate(s) as per Annexure 9. The technical and financial capability of a particular company/ particular project, including its Parents and/or Affiliates, shall not be used directly or indirectly by more than one Bidder/ Member of a Bidding Consortium/ Bidding Company. However, development and construction experience of a particular project may be used by more than one company.

The determination of the relationship of Parent or Affiliate with the Bidding Company or with the Member of the Bidding Consortium, including the Lead Member, shall be on the date at the most seven (7) days prior to the last date of submission of the Bid. Documentary evidence to establish such relationship shall be furnished by the Bidder along with the Technical Bid.

If the Technically Evaluated Entity and/or Financially Evaluated Entity is an entity other than the Bidding Company or a Member in a Bidding Consortium, the Bidding Company or Member relying on such Technically Evaluated Entity and/or Financially Evaluated Entity will have to submit a legally binding undertaking supported by a board resolution from the Technically Evaluated Entity and/or Financially Evaluated Entity or its Ultimate Parent Company, that all the equity investment obligations of the Bidding Company or the Member of the Consortium shall be deemed to be equity investment obligations of the Technically Evaluated Entity and/or Financially Evaluated Entity or its Ultimate Parent Company, and in the event of any default the same shall be met by such evaluated entity or by or the Ultimate Parent Company. The Bidding Company or the Consortium Member shall have to provide information and documents relating to its relationship with such Technically Evaluated Entity and/or Financially Evaluated Entity including details about the equity shareholding between them as per Annexure 7(C).

2.1.5 A Bidder shall submit only one Bid in the same bidding process, either individually as Bidding Company or as a Member of a Bidding Consortium (including the Lead Member). It is further clarified that any of the Parent/ Affiliate/Ultimate Parent of the Bidder/ Member in a Bidding Consortium shall not separately participate directly or

indirectly in the same bidding process. Further, if any Bidder is having a Conflict of Interest with other Bidders participating in the same bidding process, the Bids of all such Bidders shall be rejected.

- 2.1.6 Notwithstanding anything stated above, BPC reserves the right to verify the authenticity of the documents submitted for meeting the Qualification Requirements and request for any additional information and documents. BPC reserves the right at its sole discretion to contact the Bidder's bank and project references and verify the Bidder's information and documents for the purpose of bid evaluation.
- 2.1.7 The Qualified Bidder(s) will be required to continue to maintain compliance with the Qualification Requirements throughout the bidding process and till execution of the Transmission Service Agreement. Where the Technically Evaluated Entity and/or the Financially Evaluated Entity is not the Bidding Company or a Member in a Bidding Consortium, as the case may be, the Bidding Company or Member shall continue to be an Affiliate of the Technically Evaluated Entity and/or Financially Evaluated Entity till the execution of the Transmission Service Agreement. Failure to comply with the aforesaid provisions shall make the Bid liable for rejection at any stage.
- 2.1.8 The Selected Bidder will be required to continue to maintain compliance with the Qualification Requirements till the COD of the Project. Where the Technically Evaluated Entity and/or the Financially Evaluated Entity is not the Bidding Company or a Member in a Bidding Consortium, as the case may be, the Bidding Company or Member shall continue to be an Affiliate of the Technically Evaluated Entity and/or Financially Evaluated Entity till the COD of the Project. Failure to comply with the aforesaid provisions shall be dealt as per provisions of Transmission Service Agreement.
- 2.1.9 On the Bid Deadline, for the Bidder to be eligible to participate in the bidding process:
- a. the Bidder & any of its Affiliate including any Consortium Member & any of its Affiliate, their directors or key personnel should not have been barred or included in the blacklist by any government agency or authority in India, the government of the jurisdiction of the Bidder or Members where they are incorporated or the jurisdiction of their principal place of business, any international financial institution such as the World Bank Group, Asian Development Bank, African Development Bank, Inter-American Development Bank, Asian Infrastructure Investment Bank etc or the United Nations or any of its agencies; or
 - b. the Bidder & any of its Affiliate including any Consortium Member & any of its Affiliate or their directors should not have been convicted of any offence in India or abroad.

In case any investigation is pending against the Bidder, including any Consortium Member or Affiliate, or CEO or any of the directors/ manager/key managerial personnel of the Bidder /Consortium /Member or their Affiliates, full details of such investigation including the name of the investigating agency, the charge/offence for which the investigation has been launched, name and designation of persons against whom the investigation has been launched and other relevant information should be disclosed while submitting the Bid.

The Bidders shall confirm the above through a notarized affidavit as per Annexure 22.

2.2 Submission of Bid by the Bidder

- 2.2.1 The information and documents in Technical Bid will be submitted by the Bidder as per the formats specified in Section – 4 (Formats for RFP) of this document
- 2.2.2 Strict adherence to the formats wherever specified, is required. Wherever, information has been sought in specified formats, the Bidder shall refrain from referring to brochures/ pamphlets. Non-adherence to formats and/ or submission of incomplete information may be a ground for declaring the Technical Bid as non-responsive. Each format has to be duly signed and stamped by the authorized signatory of Bidder.
- 2.2.3 The Technical Bid shall contain unconsolidated/consolidated audited annual accounts (consisting of unabridged Balance Sheet, Profit and Loss Account, profit appropriation account, Auditors Report, etc.), as the case may be, of Bidding Company or each Member in Consortium including Lead Member or the Financially Evaluated Entity for the last three (3) financial years immediately preceding the last date for submission of Bid for the purpose of calculation of Networth.

In case the annual accounts for the financial year immediately preceding the Bid Deadline is not audited, the Bidder shall give declaration in this regard duly certified by its statutory auditor. In such a case, the Bidder shall provide the audited annual accounts for the three (3) financial years preceding the financial year as above for which the annual accounts have not been audited.

2.2.4 Bid submitted by a Bidding Consortium:

- 2.2.4.1 The Technical Bid shall contain a legally enforceable Consortium Agreement entered amongst the Members in the Bidding Consortium, designating one of the Members to be the Lead Member (as per Annexure 6). There shall be only one Lead Member which shall continue to hold twenty six percent (26%) equity in the TSP and cannot be changed upto one (1) year from the Commercial Operation Date (COD) of the Project. Each Member in Bidding Consortium shall duly sign the Consortium Agreement making it liable for raising the required funds for its respective equity investment commitment as specified in the Consortium Agreement. In absence of Consortium Agreement, the Technical Bid will not be considered for evaluation and will be rejected.

Provided that the Lead Member of the Bidding Consortium will be required to be liable to the extent of 100% of the total proposed commitment of equity investment of the Bidding Consortium i.e. for both its own equity contribution as well as the equity contribution of other Members.

Provided further that the Consortium Agreement shall not be amended without the explicit approval of the BPC.

The Lead Member of the Consortium will be the single point of contact for the purposes of the bid process before the date of signing of Share Purchase Agreement. Settlement of any dispute amongst the Consortium Members shall not be the responsibility of the BPC and/or the CTU and the BPC and/or the CTU shall not bear any liability whatsoever on this account.

- 2.2.4.2 The Lead Member should designate at the most two persons to represent the Consortium in its dealings with the BPC. The person(s) designated by the Lead Member should be authorized through a Power of Attorney (as per Annexure 3) to perform all tasks

including, but not limited to providing information, responding to enquiries, signing of Technical Bid on behalf of the Consortium, etc. The Bidding Consortium shall provide board resolutions from their respective Boards for committing their respective portion of equity requirement for the Project. Additionally, the Lead member shall provide a Board resolution committing to make good any shortfall in the equity for the project, in case of any member not meeting its equity commitment.

- 2.2.4.3 The Technical Bid should also contain signed Letter of Consent (as per Annexure 2) from each Member in Consortium confirming that the entire Technical and Financial Bids has been reviewed and each element of the Technical and Financial Bids is agreed to by them including investment commitment for the Project.

In addition, the Technical Bid should also contain Board Resolution from each Member of the Consortium other than the Lead Member in favour of their respective authorized representatives for executing the POA, Consortium Agreement and signing of the requisite formats.

2.2.5 Bid submitted by a Bidding Company

- 2.2.5.1 The Bidding Company should designate at the most two persons to represent the Bidding Company in its dealings with BPC. The person(s) should be authorized to perform all tasks including, but not limited to providing information, responding to enquiries, signing of Technical and Financial Bids etc. The Bidding Company should submit, along with Technical Bid, a Power of Attorney (as per Annexure 3), authorizing the signatory of the Technical and Financial Bids. The Bidding Company shall submit the board resolution committing 100% of equity requirement for the Project, in the Technical Bid.

2.3 Clarifications & Pre-Bid Meeting

- 2.3.1 The Bidders may seek clarifications or suggest amendments to the RFP by sending an email to the BPC at the email id indicated in Clause 2.14 within the date and time mentioned in Clause 2.7.2. For any such clarifications or amendments, the Bidders should adhere to the format as per Annexure – 19.
- 2.3.2 Only those Bidders or their authorized representatives, who have purchased the RFP documents are invited to attend the pre-bid meeting(s), which will take place on date as specified in Clause 2.7.2, or any such other date as notified by the BPC. The time and address of this would be intimated later.
- 2.3.3 The purpose of the pre-bid meeting will be to clarify any issues regarding the RFP, including in particular, issues raised in writing by the Bidders as per the provisions of Clause 2.3.1.
- 2.3.4 Non-attendance at the pre-bid meeting will not be a cause for disqualification of a Bidder.
- 2.3.5 The BPC is not under any obligation to entertain / respond to suggestions made or to incorporate modifications sought for.
- 2.3.6 In case Bidders need any further clarifications not involving any amendments in respect of final RFP, they should ensure that request for such clarification is submitted through e-mail to the BPC at least ten (10) days prior to the Bid Deadline as mentioned in Clause

2.7.1. The BPC may issue clarifications only, as per its sole discretion, which is considered reasonable by it. Any such clarification issued shall be sent to all the Bidders to whom the RFP has been issued. Clarifications sought after this date shall not be considered in any manner and shall be deemed not to have been received. There shall be no extension in Bid Deadline on account of clarifications sought as per this clause 2.3.6.

2.4 Amendment of RFP

- 2.4.1. At any time before the timeline mentioned in Clause 2.7.1, the BPC may, for any reason, whether at its own initiative or in response to clarifications requested by any Bidder modify or amend the RFP, including the timelines specified in Clause 2.7.2 by issuance of addendum/modification/errata and/or revised document. Such document shall be notified in writing through a letter or fax or e-mail to all the entities to which the RFP has been issued and shall be binding on them. In order to ensure that Bidders have reasonable time to take the modification into account in preparing their Bid, or for any other reasons, BPC may at its discretion, extend the due date for submission of Bid. Late receipt of any addendum/modification/errata and/or revised document will not relieve the Bidder from being bound by that modification.
- 2.4.2. All modifications shall become part of the terms and conditions of this RFP. No interpretation, revision or communication regarding this RFP is valid, unless made in writing.
- 2.4.3. The amendment to the RFP shall be notified to all the Bidders through the electronic bidding platform and shall be binding on them.

2.5 The Bidding Process

The entire bidding process shall be conducted on electronic bidding platform created by MSTC Limited. The Bid shall comprise of the Technical Bid and the Financial Bid. The Bidders shall submit the Technical Bid & Financial Bid through the electronic bidding platform. In addition to the online submission, the Bidder with lowest Final Offer will be required to submit original hard copies of Annexure 3, Annexure 4 (if applicable), Annexure 6 (if applicable) and Annexure 14 before issuance of LoI. There shall be no physical submission of the Financial Bid.

Evaluation of Technical Bid will be carried out considering the information and documents furnished by the Bidders as required under this RFP. This step would involve responsiveness check, technical and financial evaluation of the details/documents furnished by the Bidding Company / Bidding Consortium in support of meeting the Qualification Requirements. Bidders meeting the Qualification Requirements, subject to evaluation as specified in Clause 3.2 to 3.4 shall be declared as “Qualified Bidders” and eligible for opening of Initial Offer. The BPC shall also upload the list of all Qualified Bidders and Non-Qualified Bidders on the bidding portal along with the reasons for non-qualification. Also, the Financial Bids of Qualified Bidders shall be opened after at least 24 hours from the date of declaration of the Technically Qualified Bidders.

The Financial Bid will comprise of two rounds. In the first round the Initial Offer (submitted online along with the Technical Bids) of the responsive bids would be opened and Quoted Transmission Charges of Initial Offer shall be ranked on the basis of ascending order for determination of the Qualified Bidders as provided in Section-III of RFP. The Qualified Bidders, in the first fifty per cent of the ranking (with any fraction

rounded off to higher integer) or four Qualified Bidders, whichever is higher, shall qualify for participating in the electronic reverse auction stage and submit their Final Offer.

Provided however, in case only one Bidder remains after the evaluation of Technical Bid as per Clause 3.2, 3.3 and Clause 3.4, the Initial Offer of such Bidder shall not be opened and the matter shall be referred to the Government.

Provided that in the event the number of qualified Technical Bids is between two and four, then each of the qualified Bidder shall be considered as “Qualified Bidders”.

Provided that in the event of identical Quoted Transmission Charges discovered from the Initial Offer having been submitted by one or more Bidders, all such Bidders shall be assigned the same rank for the purposes of determination of Qualified Bidders. In such cases, all the Qualified Bidders who share the same rank till 50% of the rank (with any fraction rounded off to higher integer) determined above, shall qualify to participate in the electronic e-reverse auction stage. In case 50% of the ranks (with any fraction rounded off to higher integer) is having less than 4 (four) Bidders and the rank of the fourth (4th) Bidder is shared by more than one (1) Bidder, then all such Bidders who share the rank of the fourth (4th) Bidder shall qualify to participate in the electronic reverse auction.

The applicable ceiling for electronic reverse bidding shall be the lowest Quoted Transmission Charges discovered from the Initial Offer received from the Qualified Bidders. The Qualified Bidders shall be permitted to place their Final Offer on the electronic bidding platform, which is lower than zero point two five (0.25) % of the prevailing lowest Quoted Transmission Charges.

The initial period for conducting the e-reverse bidding should be 2 hours which will be extended by 30 minutes from the last received bid time, if the bid is received during the last 30 minutes of the scheduled or extended bid time. Subsequently, it will be extended again by 30 minutes from the latest received bid time.

The technical details with respect to access to such electronic platform are provided in Annexure-A (Technical Details with respect to electronic reverse auction).

In case of any technical clarification regarding access to the electronic reverse auction platform or conduct of the auction process, the Bidders may contact MSTC Limited directly at the address provided in Annexure-A.

2.5.1 Bid Formats

The Bids in response to this RFP will be submitted online through the electronic bidding platform by the Bidders in the manner provided in Clause 2.9. The Bids shall comprise of the following:

2.5.2 Technical Bid comprising of:

1. Covering Letter (as per prescribed format enclosed as **Annexure 1**);
2. Letter of Consent from Consortium Members in **Annexure 2**;

3. Power of attorney issued by the Bidding Company or the Lead Member of the Consortium, as the case may be, in favour of the person signing the Bid, in the format attached hereto as **Annexure 3**.

Additionally, in case of a Bidding Consortium, the power of attorney in favour of the Lead Member issued by the other Members of the Consortium shall be provided in as per format attached hereto as **Annexure 4**. Further, the Lead Member shall furnish Board resolution(s) from each Member of the Consortium other than the Lead Member in favour of their respective authorized representatives for executing the POA and signing of the requisite formats.

Provided that in the event the Bidding Company or the Lead Member of the Consortium or any Member of the Bidding Consortium, as the case may be, is a foreign entity, it may issue Board resolutions in place of power of attorney for the purpose of fulfilling these requirements.

4. Bidder's composition and ownership structure in **Annexure 5**
5. Format for Authorization submitted in Non-Judicial stamp paper duly notarized as per **Annexure 5** from the Bidding Company / each Member of the Consortium authorizing the BPC to seek reference from their respective bankers & others.
6. In case of Bidding Consortium, the Consortium Agreement shall be provided in as per format attached hereto as **Annexure 6**
7. Format of Qualification Requirement (**Annexures 7A, 7B, 7C and 7D**)
8. Bidders Undertakings and details of equity investment in Project (as per prescribed formats 1 and 2 of **Annexure 8**);
9. Authorization from Parent / Affiliate of Bidding Company / Member of Bidding Consortium whose technical / financial capability has been used by the Bidding Company / Member of Bidding Consortium (**Annexure 9**).
10. Undertaking from the Technically / Financially Evaluated Entity(ies) **OR** Undertaking from the Ultimate Parent Company, for total equity investment commitment, in the prescribed format in **Annexure – 10**, to meet any shortfall in the equity investment by the Selected Bidder in the Kallam Transco Limited.

Note: The effective Equity holding of the Selected Bidder in the Kallam Transco Limited, as specified in Clause 2.5.8.1 shall be computed as per the provisions of Clause 2.5.8.3 of this RFP.

Provided further, in case the Bidding Company or Member of a Consortium, (as the case may be) holds at least twenty six percent (26%) equity in such Technically/ Financially Evaluated Entities, whose credentials have been considered for the purpose of meeting the Qualification Requirements as per the RFP, no such Undertaking shall be required from the Technically / Financially Evaluated Entities.

11. Board resolutions, as per prescribed formats enclosed as Annexure – 11, duly certified by the Company Secretary or any Whole-time Director / Manager (supported by a specific Board Resolution), as applicable to the Bidder and mentioned hereunder,

- (a) Board resolution from the Bidding Company (and any investing Affiliate / Parent Company / Ultimate Parent Company) committing one hundred percent (100%) in aggregate of the equity requirement for the Project - Format-1 of **Annexure 11**;
- (b) Board resolutions from each of the Consortium Member of the Bidding Consortium (and any investing Affiliate / Parent Company / Ultimate Parent Company) together committing to one hundred percent (100%) in aggregate of equity requirement for the Project, in case Bidder is a Bidding Consortium - Format-1 of **Annexure 11**;
- (c) In either of the cases as in (a) or (b) above as applicable, Board resolutions as per Format 2 of **Annexure 11** for total equity investment commitment from the Technically / Financially Evaluated Entity(ies) whose technical / financial credentials had been considered for the purpose of meeting Qualification Requirements as per the RFP

OR

Board resolutions as per Format 2 of **Annexure 11** from the Parent Company or the Ultimate Parent Company for total equity investment commitment.

Provided that such Board resolutions, as specified in (a) or (b) or (c) above, in case of a foreign entity, shall be supported by an unqualified opinion issued by an independent legal counsel practicing in the relevant country, stating that the Board resolutions are in compliance with the applicable laws of the respective jurisdictions of the issuing company and the authorizations granted therein are true and valid.

For clarity sake, illustrations identifying which Board Resolution shall be applicable in typical cases are provided in **Annexure 11A**.

- 12. Format for Illustration of Affiliates at the most seven (7) days prior to Bid Deadline, duly certified by Company Secretary and supported by documentary evidence (**Annexure 12**).

Certified copy of the Register of Members / Demat Account Statement, Share Certificate, Annual Return filed with ROC etc. submitted as documentary evidence along with **Annexure 12**.

- 13. Disclosure as per **Annexure 13** regarding participation of any related companies in this bidding process.
- 14. Bid Bond, as per the prescribed format at **Annexure 14** ~~or Bid Security Declaration as per prescribed format at **Annexure-14A**~~ (**as applicable**);
- 15. Checklist for Technical Bid submission requirements as per **Annexure 16**.
- 16. Last three (3) financial years' unconsolidated / consolidated audited annual accounts / statements, as the case may be, of the Financially Evaluated Entity / Technical Evaluated Entity

17. Unconsolidated audited annual accounts of both the TEE and the Bidding Company/Lead member, as applicable, for the financial years in which financial closure was achieved and the financial year in which the said project was completed / commissioned.
18. Copy of the Memorandum and Articles of Association and certificate of incorporation or other organizational document (as applicable), including their amendments, certified by the Company Secretary of Bidding Company or each Member in case of a Consortium including Lead Member.
19. For each project listed in Annexure 7(D), certified true copy of the certificates of final acceptance and / or certificates of good operating performance duly issued by owners or clients for the project, duly signed by authorized signatory.

In addition to the online submission of above formats through the electronic platform, the Bidder with lowest Final Offer will be required to submit original hard copies of Annexure 3, Annexure 4 (if applicable), Annexure 6 (if applicable) and Annexure 14 before issuance of LoI. In case, there is a discrepancy between the online submission and physical documents, the bid would be outrightly rejected and the bidder shall be construed to have engaged in the fraudulent practice as defined in Clause 2.19.3 with consequences as mentioned in Clause 2.19.2.

2.5.3 Financial Bid (as per prescribed format at Annexure-21)

Financial Bid shall comprise of: (i) the Initial Offer; and (ii) the Final Offer. The Initial Offer is required to be submitted along with the Technical Bid. It is hereby clarified that the Financial Bid will comprise of two rounds. In the first round the Initial Offer of the responsive bids would be opened and Quoted Transmission Charges of Initial Offer shall be ranked on the basis of ascending order for determination of the Qualified Bidders as provided in Section-III of RFP.

In accordance with clause 2.5 of this RFP, the qualified Bidders shall be eligible to participate in the electronic reverse auction and submit their Final Offer.

The applicable ceiling for electronic reverse bidding shall be the lowest Quoted Transmission Charges discovered from the Initial Offer received from the Qualified Bidders. The Qualified Bidders shall be permitted to place their Final Offer on the electronic bidding platform, which is lower than zero point two five (0.25) % of the prevailing lowest Quoted Transmission Charges.

The initial period for conducting the e-reverse bidding should be 2 hours which will be extended by 30 minutes from the last received bid time, if the bid is received during the last 30 minutes of the scheduled or extended bid time. Subsequently, it will be extended again by 30 minutes from the latest received bid time.

The Bidders shall inter-alia take into account the following while preparing and submitting the Initial Offer and Final Offer of Financial Bid:-

- a. The Bidders shall quote single annual Quoted Transmission Charges for a period of 35 years commencing from the Scheduled COD of the Project.

- b. The Quoted Transmission Charges as per the format at Annexure-21 shall be inclusive of all charges and no exclusions shall be allowed. The Bidders shall take into account all costs including capital and operating, statutory taxes, duties, levies. Availability of the inputs necessary for operation and maintenance of the Project should be ensured by the TSP at the Project site and all costs involved in procuring the inputs (including statutory taxes, duties, levies thereof) at the Project site must be included in the Quoted Transmission Charges.
- c. Annexure 21 duly digitally signed by authorized signatory.

2.5.4 Wherever information has been sought in specified formats, the Bidders shall fill in the details as per the prescribed formats and shall refrain from referring to any other document for providing any information required in the prescribed format.

2.5.5 Transmission Charges

- 2.5.5.1. The Transmission Charges shall be specified in the Transmission Service Agreement and shall be payable to the TSP in Indian Rupees only. The Bidders shall quote single Transmission Charges as per the format at Annexure – 21.
- 2.5.5.2. The Transmission Charges of the Selected Bidder shall be inserted in Schedule 5 of the Transmission Service Agreement.

2.5.6 Bidders may note that:

- a) All the information and documents in Bid shall be submitted in English language only.
- b) Bidders shall mention the name, designation, telephone number, fax number, email address of the authorized signatory and complete address of the Bidder in the covering letter.
- c) All pages of the Bid submitted shall be initialed and stamped by the authorized signatory on behalf of the Bidder.
- d) A Bidder shall submit only one Bid in the same bidding process, either individually as Bidding Company or as a Member of a Bidding Consortium.
- e) The technical and financial capability of a particular company / particular project (Parent and/ or Affiliate) shall not be used directly or indirectly by more than one Bidder/ Member of a Bidding Consortium including Lead Member / Bidding Company.
- f) This Request for Proposal (RFP) document is not transferable. The RFP document and the information contained therein is for the use only by the Bidder to whom it is issued. It may not be copied or distributed by the recipient to third parties (other than in confidence to the recipient's professional advisors). In the event that the recipient does not continue with its involvement in the Project, this RFP document must be kept confidential.
- g) Though adequate care has been taken while preparing this RFP document, the Bidder shall satisfy himself that the document is complete in all respects. Intimation of any discrepancy shall be given to the BPC immediately. If no intimation is received from

any Bidder within ten (10) days from the date of issue of RFP document, it shall be considered that the RFP document is complete in all respects and has been received by the Bidder.

- h) Bids submitted by the Bidder and opened on scheduled date and time as stipulated in this RFP shall become the property of the BPC and BPC shall have no obligation to return the same to the Bidder.
- i) If any Bidder conceals any material information or makes a wrong statement or misrepresents facts or makes a misleading statement in its Bid, in any manner whatsoever, the BPC reserves the right to reject such Bid or cancel the Letter of Intent, if issued. If such event is discovered after the Effective Date, consequences specified in Transmission Service Agreement shall apply.
- j) If for any reason the Bid of the Bidder with the lowest Quoted Transmission Charges is not selected or Letter of Intent issued to such Selected Bidder is cancelled or such Bidder withdraws its Bids, the BPC may :-
- i. Invite all the remaining Bidders to revalidate or extend their respective Bid Security, as necessary, and match the Bid of the Bidder with the lowest Quoted Transmission Charges (the “second round of bidding”) with following cases:
 - If in the second round of bidding, only one Bidder matches the Bid of the Bidder with lowest Quoted Transmission Charges, it shall be the Selected Bidder.
 - If two or more Bidders match the Bid of the Bidder with the lowest Quoted Transmission Charges in the second round of bidding, then the Bidder whose Quoted Transmission Charges was lower as compared to other Bidder(s) in the first round of bidding shall be the Selected Bidder. For example, if the third and fifth lowest Bidders in the first round of bidding offer to match the Bid of the Bidder with lowest Quoted Transmission Charges in the second round of bidding, the said third lowest Bidder shall be the Successful Bidder.
 - In the event that no Bidder offers to match the Bid of the Bidder with the lowest Quoted Transmission Charges in the second round of bidding, the BPC may, in its discretion, invite fresh Bids (the “third round of bidding”) from all Bidders except the Bidder which quoted the lowest Quoted Transmission Charges in the first round of bidding. In case the Bidders are invited for the third round of bidding to revalidate or extend their Bid Security, as necessary, and offer fresh Bids, they shall be eligible for submission of fresh Bids provided, however, that in such third round of bidding only such Bids shall be eligible for consideration which are lower than the Quoted Transmission Charges of the second lowest Bidder in the first round of bidding; or
 - ii. Annul the bid process; or
 - iii. Take any such measure as may be deemed fit in the sole discretion of the BPC¹
- k) The BPC may, at its sole discretion, ask for additional information / document and/or

¹ BPC shall record reasons for the same.

seek clarifications from a Bidder after the Bid Deadline, inter alia, for the purposes of removal of inconsistencies or infirmities in its Bid. However, no change in the substance of the Quoted Transmission Charges shall be sought or permitted by the BPC.

- l) Non submission and/or submission of incomplete data/ information required under the provisions of RFP shall not be construed as waiver on the part of BPC of the obligation of the Bidder to furnish the said data / information unless the waiver is in writing.
- m) Bidders shall familiarize itself with the procedures and time frames required to obtain all Consents, Clearances and Permits.
- n) All Bidders are required to ensure compliance with the standards and codes mentioned in Clause 1.6.1.2.
- o) BPC reserves the right to reject all Bids and/or annul the process of tariff based competitive bidding for selection of Bidder as TSP to execute the Project without assigning any reason. BPC shall not bear any liability, whatsoever, in this regard.
- p) Foreign companies submitting the Bid are required to follow the applicable law in their country for execution of POA, Consortium Agreement and affixation of Common Seal (wherever required) and in such cases, their Bid should be supported by an unqualified opinion issued by an independent legal counsel practicing in the relevant country, stating that execution of such POA, Consortium Agreement and the authorizations granted therein are true and valid. Foreign companies executing POA outside India shall necessarily pay the adequate stamp charges in India as per the provisions of Stamp Act.

2.5.7 Bidders to inform themselves fully

2.5.7.1. The Bidders shall make independent enquiry and satisfy themselves with respect to all the required information, inputs, conditions and circumstances and factors that may have any effect on his Bid. Once the Bidders have submitted their Bids, the Bidders shall be deemed to have inspected and examined the site conditions (including but not limited to its surroundings, its geological condition and the adequacy of transport facilities to the site), the laws and regulations in force in India, the transportation facilities available in India, the grid conditions, the adequacy and conditions of roads, bridges, railway sidings, ports, etc. for unloading and/or transporting heavy pieces of material and has based its design, equipment size and fixed its price taking into account all such relevant conditions and also the risks, contingencies and other circumstances which may influence or affect the transmission of power. Accordingly, each Bidder acknowledges that, on being selected as Successful Bidder and on acquisition of one hundred percent (100%) of the equity shares of the Kallam Transco Limited, the TSP shall not be relieved from any of its obligations under the RFP Project Documents nor shall the TSP be entitled to any extension in Scheduled COD mentioned in this RFP or financial compensation for any reason whatsoever.

2.5.7.2. In their own interest, the Bidders are requested to familiarize themselves with all relevant laws of India, including without limitation, the Electricity Act 2003, the Income Tax Act 1961, the Companies Act, 1956 / Companies Act, 2013 (as the case may be), Environment Protection Act 1986 and Forest (Conservation) Act, 1980, the Customs Act, the Foreign Exchange Management Act, Land Acquisition Act, 1894, the

Indian Telegraph Act 1885, Labor & Employment Laws of India, [Insurance Act] the regulations/standards framed by the Commissions and CEA, all other related acts, laws, rules and regulations prevalent in India, as amended from time to time.

In addition to the above, the Bidders are required to familiarize themselves with all relevant technical codes and standards, including but not limited to the Grid Code / State Grid Code, Central Electricity Authority (Installation and Operations of Meters) Regulations, 2006, Central Electricity Authority (Technical Standards for Connectivity to the Grid) Regulations, 2007, Central Electricity Regulatory Commission Grant of Connectivity, Long-term Access and Medium - Term Open Access in Inter-State Transmission and related matters) Regulations, 2009, Central Electricity Authority (Technical Standards for construction of Electrical Plants and Electric Lines) Regulation, 2010, Central Electricity Authority (Technical Standards for Communication System in Power System Operation) Regulations, 2020, Central Electricity Regulatory Commission (Sharing of Inter-State Transmission Charges and Losses) Regulations, 2020 and other relevant Rules/ Regulations/ Guidelines issued by the Central Government, the CERC and the CEA and amendments thereof.

The BPC shall not entertain any request for clarifications from the Bidders regarding the above laws / acts / rules / regulations / standards. Non-awareness of the same shall not be a reason for the Bidder to request for extension in Bid Deadline. The Bidders undertake and agree that, before submission of their Bid, all such factors as generally brought out above, have been fully investigated and considered while submitting their Bids.

- 2.5.7.3. The Survey Report has been prepared in good faith, and on best endeavor basis. Neither BPC & Nodal Agency nor their employees or advisors/consultants make any representation or warranty, express or implied, or accept any responsibility or liability, whatsoever, in respect of any statements or omissions made in the Survey Report, or the accuracy, completeness or reliability of information contained therein, and shall incur no liability under any law, statute, rules or regulations as to the accuracy, reliability or completeness of such Survey Report, even if any loss or damage is caused to the Bidders by any act or omission on their part.
- 2.5.7.4. Bidders shall make best efforts and carry out its own due diligence upon survey report provided by BPC and shall consider all possible techno-commercial factors before submission of Bid. Bidders may also visit the route of the Transmission Lines associated with the Project and the surrounding areas and obtain / verify all information which they deem fit and necessary for the preparation of their Bid. Bidders may also carry out required surveys and field investigation for submission of their Bid. Bidders may also opt for any other route and is not bound to follow the route suggested in survey report provided by BPC.
- 2.5.7.5. Failure to investigate, examine and to inspect site or subsurface conditions fully shall not be grounds for a Bidder to alter its Bid after the Bid Deadline nor shall it relieve a Bidder from any responsibility for appropriately eliminating the difficulty or costs of successfully completing the Project.
- 2.5.7.6. The Selected Bidder shall obtain all necessary Consents, Clearances and Permits as required. The Bidders shall familiarize itself with the procedures and time frame required to obtain such Consents, Clearances and Permits.

2.5.7.7. The technical requirements of integrated grid operation are specified in the Indian Electricity Grid Code (IEGC). The Bidders should particularly acquaint themselves with the requirements of connection conditions, operating code for regional grids, scheduling and dispatch instructions/codes, etc. The Bidders are also advised to fully familiarize themselves with the real time grid conditions in the country. Information regarding grid parameters such as voltage and frequency is available on the websites of Regional / State Load Despatch Centers.

2.5.8 Minimum Equity holding/Equity Lock-in

2.5.8.1. (a) The aggregate equity share holding of the Selected Bidder, in the issued and paid up equity share capital of Kallam Transco Limited shall not be less than Fifty one percent (51%) up to a period of (1) one year after COD of the Project;

(b) In case the Selected Bidder is a Bidding Consortium, then any Member (other than the Lead Member) of such Bidding Consortium shall be allowed to divest its equity as long as the other remaining Members (which shall always include the Lead Member) hold the minimum equity specified in (a) above.

(c) If equity is held by the Affiliates, Parent Company or Ultimate Parent Company, then subject to the second proviso of this Clause 2.5.8.1 (c), such Affiliate, Parent Company or Ultimate Parent Company shall be permitted to transfer its shareholding in Kallam Transco Limited to another Affiliate or to the Parent Company / Ultimate Parent Company. If any such shareholding entity, qualifying as an Affiliate / Parent Company / Ultimate Parent Company, is likely to cease to meet the criteria to qualify as an Affiliate / Parent Company / Ultimate Parent Company, the shares held by such entity shall be transferred to another Affiliate / Parent Company / Ultimate Parent Company.

Provided that in case the Lead Member or Bidding Company is holding equity through Affiliate/s, Ultimate Parent Company or Parent Company, such restriction shall apply to such entities.

Provided further, that the aggregate equity share holding of the Bidding Consortium or a Bidding Company in the issued and paid up equity share capital of Kallam Transco Limited shall not be less than fifty one percent (51%) up to a period of one (1) year after COD of the Project and the lead Member of the Consortium shall have the equity share holding not less than twenty six percent (26%). In case the Selected Bidder is a Bidding Consortium, then any Member (other than the Lead Member) of such Bidding Consortium shall be allowed to divest its equity as long as the other remaining Members (which shall always include the Lead Member) hold the minimum equity specified in (a) above.

(d) All transfer(s) of shareholding of Kallam Transco Limited by any of the entities referred to above, shall be after prior written intimation to the Nodal Agency.

2.5.8.2. The Selected Bidder may invest in the equity share capital of Kallam Transco Limited through its Affiliate(s) or Ultimate Parent Company or Parent Company. Details of such investment will have to be specified in the Technical Bid as per Format 2 of Annexure 8 of the RFP. If the Selected Bidder so invests through any Affiliate(s) or Ultimate Parent Company or Parent Company, the Selected Bidder shall be liable to ensure that minimum equity holding/lock-in limits specified in Clause 2.5.8.1 and as computed as per the provisions of Clause 2.5.8.3 are still maintained.

- 2.5.8.3. For computation of effective Equity holding, the Equity holding of the Selected Bidder or its Ultimate Parent Company in such Affiliate(s) or Parent Company and the equity holding of such Affiliate (s) or Ultimate Parent Company in Kallam Transco Limited shall be computed in accordance with the example given below:

If the Parent Company or the Ultimate Parent Company of the Selected Bidder A directly holds thirty percent (30%) of the equity in Kallam Transco Limited then holding of Selected Bidder A in Kallam Transco Limited shall be thirty percent (30%);

If Selected Bidder A holds thirty percent (30%) equity of the Affiliate and the Affiliate holds fifty percent (50%) equity in Kallam Transco Limited, then for the purposes of ascertaining the minimum equity/equity lock-in requirements specified above, the effective holding of Bidder A in Kallam Transco Limited shall be fifteen percent (15%), (i.e., $30\% * 50\%$);

- 2.5.8.4. The provisions as contained in this Clause 2.5.8 and Article 19.1 of the Transmission Service Agreement shall override the terms of the Consortium Agreement submitted by the Bidder as part of the RFP.

2.6 Project Schedule

- 2.6.1. All Elements of the Project are required to be commissioned progressively as per the schedule given in the following table;

Sl. No.	Name of the Transmission Element	Scheduled COD in months from Effective Date	Percentage of Quoted Transmission Charges recoverable on Scheduled COD of the Element of the Project	Element(s) which are pre-required for declaring the commercial operation (COD) of the respective Element
1.	LILO of both circuits of Parli(M) – Karjat(M)/Lonikand-II (M) 400 kV D/c line (twin moose) at Kallam PS	18 months from date of SPV acquisition	100%	All Elements are required to be commissioned simultaneously as their utilization is dependent on commissioning of each other.
2.	4 Nos. 400 kV line bays at Kallam PS for LILO of both circuits of Parli(M) – Karjat(M)/Lonikand-II(M) 400 kV D/c line (twin moose) at Kallam PS			
3.	63 MVAR, 420 kV switchable line reactor (with NGR bypassing arrangement) on each ckt at Kallam PS end of Karjat – Kallam 400 kV D/c line (~140 km)			

The payment of Transmission Charges for any Element irrespective of its successful commissioning on or before its Scheduled COD shall only be considered after successful commissioning of the Element(s) which are pre-required for declaring the commercial operation of such Element as mentioned in the above table.

Scheduled COD for overall Project: 18 months from the date of SPV Transfer.

Note: List of Element(s) along with the critical Element(s) to be provided by CEA

2.7 Due dates

- 2.7.1. The Bidders should submit the Bids online through the electronic bidding platform before the Bid Deadline i.e., on or before 1400 hours (IST) on 15.12.2023. In addition to the online submission, the Bidder with lowest Final Offer will be required to submit original hard copies of Annexure 3, Annexure 4 (if applicable), Annexure 6 (if applicable) and Annexure 14 before issuance of LoI.
- 2.7.2. Important timelines are mentioned below:

Date	Event
13.10.2023	Issuance of RFP
02.11.2023	Submission of written clarifications/amendments, if any, on the RFP / RFP Project Documents by Bidders so as to reach BPC by 1700 hours. Such written clarifications/amendments shall be in the format provided in Annexure-20.
08.11.2023	Pre-Bid meeting(s)
20.11.2023	Issue of written clarifications and revised RFP documents
30.11.2023	Issue of final RFP Project Documents
15.12.2023	Submission of Bid (Online submission of Bid through electronic bidding portal)
15.12.2023	Opening of Technical Bid
26.12.2023	Short listing and announcement of Qualified Bidders on bidding portal
27.12.2023	Opening of Financial Bid - Initial Offer
28.12.2023	Electronic reverse auction (Financial Bid – Final Offer) for the Qualified Bidders.
02.01.2024	Submission of original hard copies of Annexure 3, Annexure 4, Annexure 6, as applicable and Annexure 14 by the bidder with lowest Final Offer
05.01.2024	Selection of Successful Bidder and issue of LOI
16.01.2024	Signing of RFP Project Documents and transfer of Kallam Transco Limited

- 2.7.3. To enable BPC to meet the schedule, all Bidders are expected to respond expeditiously during the bidding process. If any milestone/activity falls on a day which is not a working day or which is a public holiday then the milestone/activity shall be achieved/completed on the next working day.

2.8 Validity of the Bid

- 2.8.1. The Bid shall remain valid for a period of one hundred and eighty (180) days from the Bid Deadline. The BPC reserves the right to reject any Bid which does not meet aforementioned validity requirement.
- 2.8.2. The BPC may solicit the Bidders' consent for an extension of the period of validity of the Bid. The request and the response, thereafter, shall be in writing. In the event any Bidder refuses to extend its Bid validity as requested by the BPC, the BPC shall not be

entitled to invoke the Bid Bond. A Bidder accepting the BPC's request for validity extension shall not be permitted to modify its Bid and such Bidder shall, accordingly, extend the validity of the Bid Bond as requested by the BPC within seven (7) days of such request, failing which the Bid shall not be considered as valid.

2.9 Method of Submission

2.9.1. Both the Technical and Financial Bids duly filled in, all formats and supporting shall be scanned and uploaded online through electronic bidding platform in the manner specified in Annexure A

2.9.2. It may be noted that Technical Bid shall not contain any information/document relating to Financial Bid. If Technical Bid contains any such information/documents, the BPC shall not be responsible for premature opening of the Financial Bid.

All pages of the Bid, except for the Bid Bond (Annexure 14) and any other document executed on non-judicial stamp paper, forming part of the Bid and corrections in the Bid, if any, must be signed by the authorized signatory on behalf of the Bidder. It is clarified that the same authorized signatory shall sign all pages of the Bid. However, any published document submitted in this regard shall be signed by the authorized signatory at least on the first and last page of such document.

2.9.3. No change or supplemental information to a Bid already submitted will be accepted after the Bid Deadline, unless the same is requested for by the BPC as per Clause 2.5.6 (k).

Provided that a Bidder shall always have the right to withdraw / modify its Bid before the Bid Deadline. No Technical Bid or Initial Offer shall be modified, substituted or withdrawn by the Bidder on or after the Bid Deadline.

2.10 Preparation cost

2.10.1. The Bidders shall be responsible for all the costs associated with the preparation of the Bid and participation in discussions and attending pre-bid meetings, and finalization and execution of the RFP Project Documents (other than the TSA), etc. BPC shall not be responsible in any way for such costs, regardless of the conduct or outcome of the process of tariff based competitive bidding for selection of Bidder as TSP as per Bidding Guidelines.

2.10.2. The cost of this RFP is Rupees Five Lakh Only (Rs. 5,00,000) or U.S. Dollar Seven Thousand Only (US\$ 7,000) plus GST as per applicable rate, which shall be non-refundable. This amount shall be paid via electronic transfer to the following Bank Account:

Bank Name, Address & Branch	IDFC First Bank Limited Birla Towers, 4th Floor East Tower & LGF West Tower, Barakhamba Road, New Delhi – 110001
Bank Account Name	REC Power Development & Consultancy Limited
Bank Account No	10000697415
Bank IFSC Code No	IDFB0020101

Immediately after issuance of RFP document, the Bidder shall submit the Pre-Award Integrity Pact in the format as prescribed in Annexure B, which shall be applicable for and during the bidding process, duly signed on each page by any whole-time Director / Authorized Signatory, duly witnessed by two persons, and shall be submitted by the Bidder in two (2) originals in a separate envelope, duly superscripted with Pre-Award Integrity Pact.

The Bidder shall submit the Pre-Award Integrity Pact on non-judicial stamp paper of Rs. 100/- each duly purchased from the National Capital Territory of Delhi. In case the Bidder is in a consortium, the Pre-Award Integrity Pact shall be signed and submitted by each member of the Consortium separately.

2.11 Bid Bond

2.11.1. Each Bidder shall submit the Bid accompanied by Bid Bond issued by any of the Banks listed in Annexure-17. The Bid Bond shall be valid for a period of thirty (30) days beyond the validity of the Bid.

2.11.2. Subject to the provisions of Clause 2.15.5, the Bid Bond may be invoked by the BPC or its authorized representative, without any notice, demure, or any other legal process upon occurrence of any of the following:

- Bidder withdraws during the period of Bid Validity as specified in this RFP or as extended by mutual consent of the respective Bidder(s) and the BPC
- Failure to execute the Share Purchase Agreement as per the provisions of Clause 2.15.2; or
- Failure to furnish the Contract Performance Guarantee as per Clause 2.12; or
- Failure to acquire one hundred percent (100%) equity shares of Kallam Transco Limited, along with all its related assets and liabilities, in accordance with the provisions of Clause 2.15.2; or
- Failure to comply with the provisions of Clause 2.15.5 and Clause 2.15.6, leading to annulment of the award of the Project.
- Bidders submitting any wrong information or making any misrepresentation in their Bid as mentioned in Clause 2.5.6.

Intimation of the reasons of the invocation of the Bid Bond shall be given to the Selected Bidder by the BPC within three (3) working days after such invocation.

2.11.3. The Bid Bond of the Selected Bidder shall be returned on submission of the Contract Performance Guarantee as per Clause 2.12 and the relevant provisions of the Transmission Service Agreement.

2.11.4. The Bid Bond of all the Bidders, whose Bids are declared non-responsive, shall be returned within a period of thirty (30) days after the date on which the Financial Bids are opened.

2.11.5. The Bid Bond of all unsuccessful Bidders shall be returned and released by the BPC on the same day on which the Kallam Transco Limited is transferred to the Selected Bidder. The Bid Bond of the Successful Bidder shall be returned on submission of Contract Performance Guarantee as per Clause 2.12 of this RFP and the provisions of the Transmission Service Agreement.

2.12 Contract Performance Guarantee

2.12.1. Within ten (10) days from the date of issue of the Letter of Intent, the Selected Bidder,

on behalf of the TSP, will provide to the Nodal Agency the Contract Performance Guarantee for an amount of Rs. 3.0 Crore (Rupees Three Crore Only). The Contract Performance Guarantee shall be initially valid for a period up to three (3) months after the Scheduled COD of the Project and shall be extended from time to time to be valid for a period up to three (3) months after the COD of the Project and thereafter shall be dealt with in accordance with the provisions of the Transmission Service Agreement. The Contract Performance Guarantee shall be issued by any of the banks listed in Annexure-17.

2.12.2. In case the Selected Bidder is unable to obtain the Contract Performance Guarantee for the total amount from any one bank specified in Annexure-17, the Selected Bidder may obtain the same from not more than three (3) banks specified in Annexure-17.

2.13 Opening of Bids

2.13.1. Technical Bid will be opened by the Bid Opening Committee as per the following time schedule and in the office of Central Electricity Authority, in the online presence of Bidders' representatives who wish to attend:

Opening of Envelope (Technical Bid): 1430 hours (IST) on 15.12.2023

or such other dates as may be intimated by BPC to the Bidders.

In the event of any of above dates falling on a day which is not a working day or which is a public holiday, then the bids shall be opened on the next working day at the same venue and time.

Opening of Initial Offer: Initial Offer shall be opened by the Bid Opening Committee in presence of the Bid Evaluation Committee at 1430 hours (IST) on 27.12.2023 in the office of CEA.

2.13.2. The following information from each Bid will be read out to all the Bidders at the time of opening of Technical Bid:

- Name of the Bidding Company / Consortium Members in case of Bidding Consortium.

Information to be provided after opening of Initial Offer:

Only the lowest Initial Offer (s) shall be communicated to all the Qualified Bidders to participate in the e-reverse bidding process. During the e-reverse bidding process only the lowest prevailing bid should be visible to all the bidders on the electronic platform.

2.14 Enquiries

Written clarifications on the RFP and other RFP Project Documents as per Clause 2.3 and 2.4 may be sought from:

Chief Executive Officer,
REC Power Development and Consultancy Limited
(A wholly owned subsidiary of REC Limited)
REC Corporate Head Quarter,
D Block, Plot No. I – 4,

Sec – 29 Gurugram – 122 001

Email: pshariharan@recpdcl.in & tbc@recpdcl.in

2.15 Other Aspects

2.15.1. The draft of the Transmission Service Agreement has been attached to this RFP. In addition to above, the following documents have also been attached to this RFP:

a) Share Purchase Agreement

When the drafts of the above RFP Project Documents are provided by the BPC, these RFP Project Documents shall form part of this RFP as per Formats – 1 & 2 of Annexure 20.

Upon finalization of the RFP Project Documents after incorporating the amendments envisaged in Clause 2.4 of this RFP, all the finalized RFP Project Documents shall be provided by BPC to the Bidders at least fifteen (15) days prior to the Bid Deadline.

The Transmission Service Agreement and Share Purchase Agreement shall be signed in required number of originals so as to ensure that one (1) original is retained by each party to the Agreement(s) on the date of transfer of SPV.

2.15.2. Within ten (10) days of the issue of the Letter of Intent, the Selected Bidder shall:

- a) provide the Contract Performance Guarantee in favour of the Nodal Agency as per the provisions of Clause 2.12;
- b) execute the Share Purchase Agreement and the Transmission Service Agreement;
- c) acquire, for the Acquisition Price, one hundred percent (100%) equity shareholding of Kallam Transco Limited from REC Power Development and Consultancy Limited, who shall sell to the Selected Bidder, the equity shareholding of Kallam Transco Limited, along with all its related assets and liabilities;

Stamp duties payable on purchase of one hundred percent (100%) of the equity shareholding of Kallam Transco Limited, along with all its related assets and liabilities, shall also be borne by the Selected Bidder.

Provided further that, if for any reason attributable to the BPC, the above activities are not completed by the Selected Bidder within the above period of ten (10) days as mentioned in this Clause, such period of ten (10) days shall be extended, on a day for day basis till the end of the Bid validity period.

2.15.3. After the date of acquisition of the equity shareholding of Kallam Transco Limited, along with all its related assets and liabilities, by the Selected Bidder,

- i. the authority of the BPC in respect of this Bid Process shall forthwith cease and any actions to be taken thereafter will be undertaken by the Nodal Agency,
- ii. all rights and obligations of Kallam Transco Limited, shall be of the TSP,

- iii. any decisions taken by the BPC prior to the Effective Date shall continue to be binding on the Nodal Agency and
 - iv. contractual obligations undertaken by the BPC shall continue to be fulfilled by the TSP.
 - v. Further, the TSP shall execute the Agreement(s) required, if any, under Central Electricity Regulatory Commission (Sharing of Inter-State Transmission Charges and Losses) Regulations as amended from time to time.
- 2.15.4. Within five (5) working days of the issue of the acquisition of the SPV by the Successful Bidder, the TSP shall apply to the Commission for grant of Transmission License and make an application to the Commission for the adoption of Transmission Charges, as required under Section – 63 of The Electricity Act 2003.
- 2.15.5. If the Selected Bidder / TSP fails or refuses to comply with any of its obligations under Clauses 2.15.2, 2.15.3 and 2.15.4, and provided that the other parties are willing to execute the Share Purchase Agreement and REC Power Development and Consultancy Limited is willing to sell the entire equity shareholding of Kallam Transco Limited, along with all its related assets and liabilities, to the Selected Bidder, such failure or refusal on the part of the Selected Bidder shall constitute sufficient grounds for cancellation of the Letter of Intent. In such cases, the BPC / its authorized representative(s) shall be entitled to invoke the Bid Bond of the Selected Bidder.
- 2.15.6. If the TSP fails to obtain the Transmission License from the Commission, it will constitute sufficient grounds for annulment of award of the Project.
- 2.15.7. The annulment of award, as provided in Clauses 2.15.5 and 2.15.6 of this RFP, will be done by the Government on the recommendations of National Committee on Transmission. However, before recommending so, National Committee on Transmission will give an opportunity to the Selected Bidder / TSP to present their view point.
- 2.15.8. The annulment of the award, under Clause 2.15.5 or 2.15.6 of this RFP, shall be sufficient grounds for blacklisting the bidder, whose award has been annulled, for a period of five years or more, as decided by the National Committee on Transmission, provided that the blacklisting shall be done only after giving the bidder an opportunity for showing cause.

2.16 Confidentiality

- 2.16.1. The parties undertake to hold in confidence this RFP and RFP Project Documents and not to disclose the terms and conditions of the transaction contemplated hereby to third parties, except:
- a) to their professional advisors;
 - b) to their officers, contractors, employees, agents or representatives, financiers, who need to have access to such information for the proper performance of their activities;
 - c) disclosures required under Law, without the prior written consent of the other parties of the concerned agreements.

Provided that the TSP agrees and acknowledges that the Nodal Agency may at any time, disclose the terms and conditions of the RFP and RFP Project Documents to any person, to the extent stipulated under the Law or the Bidding Guidelines.

2.17 Right of the BPC to reject any Bid

BPC reserves the right to reject all or any of the Bids/ or cancel the RFP without assigning any reasons whatsoever and without any liability.

2.18 Non submission and/or submission of incomplete data/ information required under the provisions of RFP shall not be construed as waiver on the part of BPC of the obligation of the Bidder to furnish the said data / information unless the waiver is in writing.

2.19 Fraudulent and Corrupt Practices

2.19.1. The Bidders and their respective officers, employees, agents and advisers shall observe the highest standard of ethics during the Bid process and subsequent to the issue of the LoI Notwithstanding anything to the contrary contained herein, or in the LoI, the BPC shall reject a Bid, withdraw the LoI, as the case may be, without being liable in any manner whatsoever to the Bidder, if it determines that the Bidder has, directly or indirectly or through an agent, engaged in corrupt practice, fraudulent practice, coercive practice, undesirable practice or restrictive practice in the Bid process. In such an event, the BPC shall forfeit the Bid Bond, without prejudice to any other right or remedy that may be available to the BPC hereunder or otherwise.

2.19.2. Without prejudice to the rights of the BPC under Clause 2.19.1 hereinabove and the rights and remedies which the BPC may have under the LoI, if a Bidder is found by the BPC to have directly or indirectly or through an agent, engaged or indulged in any corrupt practice, fraudulent practice, coercive practice, undesirable practice or restrictive practice during the Bid process, or after the issue of the LoI, such Bidder & its Affiliates shall not be eligible to participate in any tender or RFP issued by any BPC for an indefinite period from the date such Bidder is found by the BPC to have directly or indirectly or through an agent, engaged or indulged in any corrupt practice, fraudulent practice, coercive practice, undesirable practice or restrictive practices, as the case may be.

2.19.3. For the purposes of this Clause 2.19, the following terms shall have the meaning hereinafter respectively assigned to them:

- a) **“corrupt practice”** means (i) the offering, giving, receiving, or soliciting, directly or indirectly, of anything of value to influence the actions of any person connected with the Bid process (for avoidance of doubt, offering of employment to or employing or engaging in any manner whatsoever, directly or indirectly, any official of the BPC who is or has been associated or dealt in any manner, directly or indirectly with the Bid process or the LoI or has dealt with matters concerning the Transmission Service Agreement or arising there from, before or after the execution thereof, at any time prior to the expiry of one year from the date such official resigns or retires from or otherwise ceases to be in the service of the BPC, shall be deemed to constitute influencing the actions of a person connected with the Bid Process); or (ii) engaging in any manner whatsoever, whether during the Bid Process or after the issue of the LoI or after the execution of the Transmission Service Agreement, as the case may be, any person in

respect of any matter relating to the Project or the LoI or the Transmission Service Agreement, who at any time has been or is a legal, financial or technical adviser of the BPC in relation to any matter concerning the Project;

- b) **"Fraudulent practice"** means a misrepresentation or omission of facts or suppression of facts or disclosure of incomplete facts, in order to influence the Bid process;
- c) **"Coercive practice"** means impairing or harming, or threatening to impair or harm, directly or indirectly, any person or property to influence any person's participation or action in the Bid process;
- d) **"undesirable practice"** means (i) establishing contact with any person connected with or employed or engaged by the BPC with the objective of canvassing, lobbying or in any manner influencing or attempting to influence the Bid process; or (ii) having a Conflict of Interest; and
- e) **"Restrictive practice"** means forming a cartel or arriving at any understanding or arrangement among Bidders with the objective of restricting or manipulating a full and fair competition in the Bid process.

SECTION - 3

EVALUATION OF THE TECHNICAL AND FINANCIAL BID

SECTION 3

1. EVALUATION OF BID

3.1. The evaluation process of Technical Bid comprises the following five steps:

- Step I – Responsiveness check
- Step II- Compliance with submission requirements
- Step III– Evaluation of Technical Bids
- Step IV– Evaluation of Financial Bids
- Step V – Bidder Selection

3.2. STEP I – Responsiveness check

The Technical Bid submitted by the Bidder shall be initially scrutinized to establish “Responsiveness”. Subject to clause 2.5.6 (k), any of the following conditions shall cause the Technical Bid to be “Non-responsive”:

- a) Technical Bid that are incomplete.
- b) Technical Bid not signed by authorized signatory and / or stamped in the manner indicated in this RFP.
- c) All pages of the Technical Bid submitted but not initialed by the authorized signatories on behalf of the Bidder.
- d) Technical Bid not including the covering letter as per Annexure 1.
- e) Technical Bid submitted by a Bidding Consortium not including the Consortium Agreement.
- f) Technical Bid contains material inconsistencies in the information and documents submitted by the Bidder, affecting the Qualification Requirements.
- g) Bidder submitting or participating in more than one Bid either as a Bidding Company or as a Member of Bidding Consortium.
- h) More than one Member of the Bidding Consortium or a Bidding Company using the credentials of the same Parent/Affiliate.
- i) Information not submitted in formats specified in the RFP.
- j) Applicable Board resolutions, or any other document, as provided in Clause 2.5.2, not being submitted;
- k) Bid not accompanied by a valid Bid Bond ~~or Bid Security Declaration, as applicable;~~
- l) Non submission of power of attorney, supported by a Board resolution;
- m) Bid validity being less than that required as per Clause 2.8 of this RFP;
- n) Bid not containing Format-1 (Bidders' Undertakings) of Annexure-8;

- o) Bidder having Conflict of Interest
- p) The Bidder has not submitted a disclosure as per Annexure 13.
- q) Bidders delaying in submission of additional information or clarifications sought by the BPC.
- r) If the Bidder makes any misrepresentation as specified in Clause 3.7.
- s) Bid being conditional in nature.
- t) More than one Member of the Bidding Consortium or a Bidding Company using the credentials of the same Parent/Affiliate.

3.3. STEP II - Compliance with submission requirements

Each Bidder's Technical Bid shall be checked for compliance with the submission requirements set forth in this RFP before the evaluation of Technical Bid is taken up. Annexure 16 and Annexure 11A shall be used to check whether each Bidder meets the stipulated requirements.

3.4. STEP III -Evaluation of Technical Bid

Evaluation of Technical Bid will be carried out considering the information and documents furnished by the Bidders as required under this RFP. This step would involve technical and financial evaluation of the details/ documents furnished by the Bidding Company / Bidding Consortium in support of meeting the Qualification Requirements

3.4.1. Interpolation of financial data.

For the Qualification Requirements data provided by the Bidders in foreign currency, equivalent rupees of Networth will be calculated using bills selling exchange rates (card rate) USD/INR of State Bank of India prevailing on the date of closing of the accounts for the respective financial year as certified by their Banker.

For the purpose of calculating the aggregate capital expenditure/construction experience of the projects completed/ commissioned where such projects are executed outside India and capital expenditure is denominated in foreign currency, bills selling exchange rates (card rate) USD/INR of State Bank of India prevailing on the date of closing of the financial year in which the projects were completed and as certified by their Banker shall be considered.

For the projects executed in the current financial year bills selling (card rate) USD/INR of State Bank of India prevailing on seven (7) days prior to the last date of submission of Technical Bid and as certified by their Banker shall be considered.

For currency other than USD, Bidders shall convert such currency into USD as per the exchange rates certified by their Banker prevailing on the relevant date and used for such conversion. Such Bidders shall submit necessary certification from their Banker for the exchange rate used in the conversation.

If the exchange rate for any of the above dates is not available, the rate for the immediately available previous day shall be taken into account.

3.4.2. Bidders meeting the Qualification Requirements, subject to evaluation as specified in Clauses 3.2 to 3.4 shall be declared as Qualified Bidders and eligible for opening of Initial Offer.

3.4.3. The BPC shall upload the list of all Qualified Bidders and Non-Qualified Bidders on the bidding portal along with the reasons for non-qualification.

3.5. STEP IV - Evaluation of Financial Bids

3.5.1. The Bids which have been found Qualified by the BPC, based on the Steps I to III as specified above in Clauses 3.2.to 3.4, shall be opened and Quoted Transmission Charges of such Initial Offer shall be ranked on the basis of the ascending Initial Offer submitted by each Qualified Bidder.

Based on such ranking of the Qualified Bidders, in the first fifty per cent of the ranking (with any fraction rounded off to higher integer) or four Qualified Bidders, whichever is higher, shall qualify for participating in the electronic reverse auction.

Provided however, in case only one Bidder remains after the Evaluation of Technical Bid (Steps 1 to III) as per Clause 3.2 to 3.4, the Initial Offer of such Bidder shall not be opened and the matter shall be referred to the Government.

Provided that in the event the number of Qualified Bidders is between two and four, then each of the responsive Bidder shall be considered as Qualified Bidders.

Provided that in the event of identical Quoted Transmission Charges discovered from the Initial Offer having been submitted by one or more Bidders, all such Bidders shall be assigned the same rank for the purposes of determination of Qualified Bidders. In such cases, all Qualified Bidders who shares the same rank till 50% of the rank (with any fraction rounded off to higher integer) determined above, shall qualify to participate in the electronic reverse auction stage. In case 50% of the rank is having less than four (4) Bidders and the rank of the fourth (4th) Bidder is shared by more than one Bidder, then all such all such Bidders who share the rank of the fourth Bidder shall qualify to participate in the electronic reverse auction.

3.5.2. The Financial Bids comprising of both Initial Offer and Final Offer submitted by the Bidders shall be scrutinized to ensure conformity with the provisions of Clause 2.5.3 of this RFP. Any Bid not meeting any of the requirements as per Clause 2.5.3 of this RFP may cause the Bid to be considered "Non-responsive", at the sole decision of the BPC. Financial Bid not in conformity with the requirement of SI. No. (c) of Clause 2.5.3 of this RFP shall be rejected.

3.5.3 The Bidders shall quote the single annual Quoted Transmission Charges as specified in the format at Annexure – 21.

3.6. STEP V - Bidder Selection

3.6.1. The prevailing lowest Quoted Transmission Charges discovered from Final Offers shall only be displayed during the e-reverse bidding and the Bidder quoting such Final Offer will always remain anonymous during the e-reverse bidding. The Bidder with the prevailing lowest Quoted Transmission Charges discovered from Final Offers at the close of the scheduled or extended period of e-reverse bidding as mentioned in clause 2.5 shall be

declared as the Successful Bidder, subject to verification of the original hard copies of Annexure 3, Annexure 4 (if applicable), Annexure 6 (if applicable) and Annexure 14. The Letter of Intent shall be issued to such Successful Bidder in two (2) copies.

However, if no bid is received during the e-reverse bidding stage then the Bidder with lowest quoted initial transmission charges ("Initial Offer") during e-bidding stage shall be declared as the Successful Bidder, subject to verification of the original hard copies of Annexure 3, Annexure 4 (if applicable), Annexure 6 (if applicable) and Annexure 14. The Letter of Intent shall be issued to such Successful Bidder in two (2) copies.

In case, there is a discrepancy between the online submission and physical documents, the bid would be out rightly rejected and the bidder shall be construed to have engaged in the fraudulent practice as defined in Clause 2.19.3 with consequences as mentioned in Clause 2.19.2. Further, in such a case, the provisions of Clause 2.5.6 (j) shall apply.

- 3.6.2. The Selected Bidder shall unconditionally accept the LoI, and record on one (1) copy of the LoI, "Accepted unconditionally", under the signature of the authorized signatory of the Successful Bidder and return such copy to the BPC within seven (7) days of issue of LoI.
- 3.6.3. If the Successful Bidder, to whom the Letter of Intent has been issued, does not fulfill any of the conditions specified in Clauses 2.15.2, 2.15.3 and Clause 2.15.4, then subject to Clause 2.15.5, the BPC reserves the right to annul the award of the Project and cancel the Letter of Intent. Further, in such a case, the provisions of Clause 2.5.6 (j) shall apply.
- 3.6.4. The BPC, in its own discretion, has the right to reject all Bids if the Quoted Transmission Charges are not aligned to the prevailing prices.

3.7. Misrepresentation by the Bidder

If the Bidder conceals any material information or makes a wrong statement or misrepresents facts or makes a misleading statement in the Technical Bid or Bid, as the case may be, in any manner whatsoever, in order to create circumstances for the acceptance of its Technical Bid/Bid, the BPC reserves the right to reject such Technical Bid/Bid, and/ or cancel the Letter of Intent, if issued. Further, in case Letter of Intent is cancelled, consequences as per provisions of the RFP shall follow.

3.8. Disposition of Technical Bid

- 3.8.1. Technical Bid found to be Non-responsive as per Clause 3.2, due to any of the following conditions, shall be liable for rejection.
- Technical Bid that is incomplete.
 - Technical Bid not signed by authorized signatory and / or stamped in the manner indicated in this RFP.
 - All pages of the Technical Bid submitted but not initialed by the authorized signatories on behalf of the Bidder.
 - Technical Bid not including the covering letter as per Annexure 1.
 - Technical Bid contains material inconsistencies in the information and documents submitted by the Bidder, affecting the Qualification Requirements.
 - Information not submitted in formats specified in the RFP.
 - The Bidder has not submitted a disclosure as per Annexure 13.
 - Bidders delaying in submission of additional information or clarifications sought by the BPC.

3.8.2. Technical Bid found to be Non-responsive as per Clause **3.2**, due to any of the following conditions, shall be rejected.

- Technical Bid not received by the scheduled date and time.
- Technical Bid submitted by a Bidding Consortium not including the Consortium Agreement.
- Bidder submitting or participating in more than one response either as a Bidding Company or as a Member of Bidding Consortium.
- More than one Member of the Bidding Consortium or a Bidding Company using the credentials of the same Parent/Affiliate.
- Technical Bid having Conflict of Interest.
- If the Bidder makes any misrepresentation as specified in Clause **3.7**.

3.9. BPC reserves the right to interpret the Bid in accordance with the provisions of this RFP document and make its own judgment regarding the interpretation of the same. In this regard, BPC shall have no liability towards any Bidder and no Bidder shall have any recourse to BPC with respect to the qualification process.

BPC shall evaluate Bid using the process specified in Clause 3.1 to 3.6, at its sole discretion. BPC's decision in this regard shall be final and binding.

SECTION - 4

ANNEXURES FOR BID

SECTION – 4**I. Formats for Bid**

The following formats are required to be included in the Bidder's Technical and Financial Bid. These formats are designed to demonstrate the Bidder's compliance with the Qualification Requirements set forth in Clause 2.1 of Section – 2.

Technical Bid

1. Format for the Covering Letter
2. Format for Letter of Consent from Consortium Members
3. Format for evidence of authorized signatory's authority (Power of Attorney)
4. Format for Power of Attorney from to be provided by each of the other Members of the Consortium in favor of the Lead Member
5. Format for Bidder's composition and ownership structure and Format for Authorization
6. Format for Consortium Agreement
7. Formats for Qualification Requirement
8. Format of Bidders Undertaking and details of Equity Investment
9. Authorization from Parent/Affiliate of Bidding Company/Member of Bidding Consortium whose technical/financial capability has been used by the Bidding Company/Member of Bidding Consortium.
10. Undertaking from the Technically / Financially Evaluated Entity(ies) or from Ultimate Parent Company for equity investment
11. Format of Board Resolutions
12. Format for Illustration of Affiliates
13. Format for Disclosure
14. Format for Bid Bond
- ~~14A. Format for Bid Security Declaration~~
15. Format for Contract Performance Guarantee
16. Checklist for Technical Bid submission requirements
22. Format for Affidavit

In addition to the online submission, the Bidder with lowest Final Offer will be required to submit original hard copies of Annexure 3, Annexure 4 (if applicable), Annexure 6 (if applicable) and Annexure 14 before issuance of LoI.

Financial Bid

21. Format for Financial Bid

II. The following formats are for the information to the Bidders to enable them to submit their Bid.

- 11A. Illustration For Applicable Board Resolution Requirements Under Clause 2.5.2
17. List of Banks
18. GRID Map of the Project
19. Format for clarification/amendments on the RFP/RFP Project Documents
20. Formats for RFP Project Documents

Bidder may use additional sheets to submit the information for its detailed Bid.

ANNEXURE 1 - COVERING LETTER

(The covering letter should be on the Letter Head of the Bidding Company/ Lead Member of the Consortium)

Date:

From:

.....

.....

Tel. No.:

Fax No.:

E-mail address:

To,

**Chief Executive Officer,
REC Power Development and Consultancy Limited
(A wholly owned subsidiary of REC Limited)
REC Corporate Head Quarter,
D Block, Plot No. I – 4,
Sec – 29 Gurugram – 122 001**

Dear Sir,

Sub: Bid for selection of Bidder as Transmission Service Provider to establish Inter-State Transmission System for “Western Region Network Expansion scheme in Kallam area of Maharashtra” through tariff based competitive bidding process.

1. Being duly authorized to present and act on behalf of M/s (insert name of Bidding Company / Bidding Consortium) (hereinafter called the “Bidder”) and having read and examined in detail the Request for Proposal (RFP) document, the undersigned hereby submit our Technical Bid with duly signed formats and Financial Bid (Initial Offer) as stipulated in RFP document for your consideration.
2. It is confirmed that our Bid is consistent with all the requirements of submission as stated in the RFP document and subsequent clarifications/amendments as per Clause 2.3 and 2.4 of RFP.
3. The information submitted in our Bid is complete, is strictly as per the requirements stipulated in the RFP document and is correct to the best of our knowledge and understanding. We would be solely responsible for any errors or omissions in our Bid.
4. We hereby agree and undertake to procure the products associated with the Transmission System as per provisions of Public Procurement (Preference to Make in India) orders issued by Ministry of Power vide orders No. 11/5/2018 - Coord. dated 28.07.2020 for transmission sector, as amended from time to time read with Department for Promotion of Industry and Internal Trade (DPIIT) orders in this regard.

We hereby also agree and undertake to comply with Department of Expenditure, Ministry of Finance vide Order (Public Procurement No 1) bearing File No. 6/18/2019-PPD dated 23.07.2020, Order (Public Procurement No 2) bearing File No. 6/18/2019-PPD dated 23.07.2020 and Order (Public Procurement No. 3) bearing File No.

6/18/2019-PPD, dated 24.07.2020, as amended from time to time, regarding public procurement from a bidder of a country, which shares land border with India.

5. We hereby agree to comply with Ministry of Power order no. 25-11/6/2018 – PG dated 02.07.2020 as amended from time to time.
6. We are herewith submitting legally binding board resolution for the total equity requirement of the Project.
7. We hereby confirm that in accordance with Clause 2.1.4 of the RFP, we are herewith submitting legally binding undertaking supported by a board resolution from the(Insert name of Technically Evaluated Entity and/or Financially Evaluated Entity or its Ultimate Parent Company, as the case may be) that all the equity investment obligations of (Insert name of the Bidding Company) shall be deemed to be equity investment obligations of the (Insert name of Technically Evaluated Entity and/or Financially Evaluated Entity or its Ultimate Parent Company, as the case may be) and in the event of any default by..... (Insert name of the Bidding Company), the same shall be met by (Insert name of Technically Evaluated Entity and/or Financially Evaluated Entity or its Ultimate Parent Company, as the case may be).

[Sl. No 7 to be inserted only in case the Bidder is a Bidding Company / Lead Member of a Consortium and has sought qualification on the basis of technical and financial capability of its Affiliate(s) and/or its Parent]

8. We confirm that there are no litigations or disputes against us, which materially affect our ability to fulfill our obligations with regard to the Project.
9. We hereby confirm that we shall continue to maintain compliance with Qualification Requirements till the execution of the Transmission Service Agreement. Further, in case we emerge as Selected Bidder for the Project, we shall continue to maintain compliance with Qualification Requirements till the COD of the Project.
10. We confirm that we have studied the provisions of relevant Indian laws and regulations required to enable us to build, own, operate and transfer the said Project and to prepare this Bid.
11. We hereby confirm that we shall abide unreservedly with BPC's decision in the qualification process for selection of Qualified Bidder and further warrant that under no circumstances we shall challenge either the BPC's decision or its right to make such decision at any time in the future.
12. We confirm that the Bid shall remain valid for a period of one eighty (180) days from the Bid Deadline.
13. The details of contact person are furnished as under:

Name:
Designation:
Name of the Company:
Address of the Bidder:
Phone Nos.:
Fax Nos.:
E-mail address:

14. Bid Bond

We have enclosed a Bid Bond of Rupees Crores (Rs.) only or US\$ (.....US Dollars), in the form of bank guarantee no.....[Insert number of the Bank Guarantee] dated.....[Insert Date of the Bank Guarantee] as per your proforma (Annexure-14) from.....[Insert name of bank providing Bid Bond] and valid up toin terms of Clause 2.11 of the RFP.

15. Acceptance

We hereby unconditionally and irrevocably agree and accept that the decision made by the BPC on any matter regarding or arising out of the RFP shall be binding on us. We hereby expressly waive any and all claims in respect of Bid process.

16. Familiarity With Relevant Indian Laws & Regulations

We confirm that we have studied the provisions of relevant Indian laws and regulations as required to enable us to submit this Bid and execute the RFP Project Documents (other than TSA), in the event of our selection as the TSP. We further undertake and agree that all such factors as mentioned in Clause 2.5.7 of RFP have been fully examined and considered while submitting the Bid.

It is confirmed that our Bid is consistent with all the requirements of submission as stated in the RFP and subsequent communications from BPC.

The information submitted in our Bid is complete, strictly as per the requirements stipulated in the RFP and is correct to the best of our knowledge and understanding. We would be solely responsible for any errors or omissions in our Bid.

We confirm that we have not taken any deviation so as to be deemed non-responsive with respect to the provisions stipulated at Clause 2.5.1, of this RFP.

Thanking you,

Yours sincerely,

.....
(Name and Signature of the authorized signatory in whose name Power of Attorney/ Board Resolution as per Clause 2.5.2 is issued)

Name:
 Designation:
 Address:

Date:
 Place:

Company Rubber Stamp

ANNEXURE 2 - LETTER OF CONSENT FROM CONSORTIUM MEMBERS

(On the letter head of each Member of the Consortium including Lead Member)

Date:
 From:

 Tel. No.:
 Fax No.:
 E-mail address:

To,

**Chief Executive Officer,
 REC Power Development and Consultancy Limited
 (A wholly owned subsidiary of REC Limited)
 REC Corporate Head Quarter,
 D Block, Plot No. I – 4,
 Sec – 29 Gurugram – 122 001**

Dear Sir,

Sub: Bid for selection of Bidder as Transmission Service Provider to establish Inter-State Transmission System for “Western Region Network Expansion scheme in Kallam area of Maharashtra” through tariff based competitive bidding process.

We, the undersigned Member of (Insert name of the Bidding Consortium) have read, examined and understood the RFP document for the short-listing of Bidders as prospective TSP to establish Inter-State Transmission System for “**Western Region Network Expansion scheme in Kallam area of Maharashtra**” through tariff based competitive bidding process. We hereby confirm our concurrence with the Bid including in particular the Consortium Agreement submitted by (Insert name of the Lead Member) in response to the RFP document.

We hereby confirm our commitment to participate in the said Bidding Consortium and invest % of the total equity requirement for the Project as per the terms of the Consortium Agreement dated and board resolution for such investment commitment is enclosed herewith.

We hereby confirm that in accordance with Clause 2.1.4 of the RFP, we are enclosing legally binding undertaking supported by a board resolution from the (Insert name of Technically Evaluated Entity and / or Financially Evaluated Entity or its Ultimate Parent Company, as the case may be) that all the equity investment obligations of (Insert name of the Member) shall be deemed to be equity investment obligations of the (Insert name of Technically Evaluated Entity and / or Financially Evaluated Entity or its Ultimate Parent Company, as the case may be) and in the event of any default by..... (Insert name of the Member), the same shall be met by..... (Insert name of Technically Evaluated Entity and / or Financially Evaluated Entity or its Ultimate Parent Company, as the case may be). [Insert if applicable]

[To be inserted by the Lead Member only] We are also enclosing legally binding board resolution for the total equity requirement of the Project in case of any breach of any of the

equity investment commitment by any of the Consortium Members, in line with the provisions of the Consortium Agreement dated [Bidder to insert date of Consortium Agreement].

The details of contact person are furnished as under:

Name:
Designation:
Name of the Company:
Address:
Phone Nos.:
Fax Nos.:
E-mail address:

Dated the day of of 20...

Thanking you,

Yours faithfully,

.....
(Signature)

Name:
Designation:

(Signature, Name, Designation of Authorized Signatory of Consortium Member and Company's Seal)

ANNEXURE 3 - FORMAT FOR EVIDENCE OF AUTHORIZED SIGNATORY'S AUTHORITY (POWER OF ATTORNEY)

POWER OF ATTORNEY

(To be on non-judicial stamp paper of appropriate value as per Stamp Act relevant to place of execution. Foreign companies submitting bids are required to follow the applicable law in their country)

Know all men by these presents, We(name and address of the registered office of the Bidder) do hereby constitute, appoint and authorize Mr./Ms.....(name and residential address) who is presently employed with us and holding the position of as our attorney, to do in our name and on our behalf, all such acts, deeds and things necessary in connection with or incidental to our Bid for selection of Bidder as Transmission Service Provider to establish Inter-State Transmission System for **“Western Region Network Expansion scheme in Kallam area of Maharashtra”** through tariff based competitive bidding process in the country of India, including signing and submission of all documents related to the Bid, including, undertakings, letters, certificates, acceptances, clarifications, guarantees, etc., making representations to the BPC, and providing information / responses to the BPC, representing us in all matters before the BPC, and generally dealing with the BPC in all matters in connection with our Bid for the said Project till the completion of the bidding process in accordance with the RFP and signing of the Share Purchase Agreement by all the parties thereto.

We hereby agree to ratify all acts, deeds and things lawfully done by our said attorney pursuant to this Power of Attorney and that all acts, deeds and things done by our aforesaid attorney shall and shall always be deemed to have been done by us.

All the terms used herein but not defined shall have the meaning ascribed to such terms under the RFP.

For [Insert name of the Bidder on whose behalf PoA is executed]

.....
(Signature)

Name:
 Designation:

Accepted

.....
(Signature of the Attorney)

Name:
 Designation:
 Address:

.....
(Name, Designation and Address of the Attorney)

Specimen signatures of attorney attested by the Executant

.....

(Signature of the Executant)

.....

(Signature of Notary Public)

Place:

Date:

Notes:

- 1) To be executed by Bidding Company or the Lead Member, in the case of a Bidding Consortium, as the case maybe.
- 2) The mode of execution of the Power of Attorney should be in accordance with the procedure, if any, laid down by the applicable law and the charter documents of the executant(s) and when it is so required, the same should be under common seal of the executant affixed in accordance with the applicable procedure. Further, the person whose signatures are to be provided on the power of attorney shall be duly authorized by the executant(s) in this regard.
- 3) Also, wherever required, the executant(s) should submit for verification the extract of the charter documents and documents such as a Board resolution / power of attorney, in favour of the Person executing this power of attorney for delegation of power hereunder on behalf of the executant(s).
- 4) In case of foreign Bidders, refer to clause 2.5.6 (p)

ANNEXURE 4 - FORMAT FOR POWER OF ATTORNEY TO BE PROVIDED BY EACH OF THE OTHER MEMBERS OF THE CONSORTIUM IN FAVOUR OF THE LEAD MEMBER

POWER OF ATTORNEY

(To be on non-judicial stamp paper of appropriate value as per Stamp Act relevant to place of execution. Foreign companies submitting bids are required to follow the applicable law in their country)

KNOW ALL MEN BY THESE PRESENTS THAT M/s....., having its registered office at,,.....and M/s having its registered office at , (Insert names and registered offices of all Members of the Consortium), the Members of Consortium, have formed a Bidding Consortium named (insert name of the Consortium) (hereinafter called the **“Consortium”**) vide Consortium Agreement dated..... and having agreed to appoint M/s..... as the Lead Member of the said Consortium do hereby constitute, nominate and appoint M/s.....a company incorporated under the laws ofand having its Registered / Head Office atas our duly constituted lawful Attorney (hereinafter called as **“Lead Member”**) which is one of the Members of the Consortium, to act as the Lead Member and our true and lawful attorney, to do in our name and on our behalf, all such acts, deeds and things necessary in connection with or incidental to submission of Consortium's Bid for the Project, including signing and submission of the Bid and all documents related to the Bid, including, undertakings, letters, certificates, acceptances, clarifications, guarantees, etc, making representations to the BPC, and providing information / responses to the BPC, representing us and the Consortium in all matters before the BPC, and generally dealing with the BPC in all matters in connection with our Bid for the said Project, till completion of the bidding process in accordance with the RFP and signing of the Share Purchase Agreement by all the parties thereto.

It is expressly understood that in the event of the Consortium being selected as Successful Bidder, this Power of Attorney shall remain valid, binding and irrevocable until the Bidding Consortium achieves execution of all RFP Project Documents.

We, as the Member of the Consortium, agree and undertake to ratify and confirm all whatsoever the said Attorney/Lead Member has done on behalf of the Consortium Members pursuant to this Power of Attorney and the same shall bind us and deemed to have been done by us.

All the terms used herein but not defined shall have the meaning ascribed to such terms under the RFP.

IN WITNESS WHEREOF M/s, as the Member of the Consortium have executed these presents on this..... day of

For and on behalf of
Consortium Member

.....
(Signature of the Authorized Signatory)

Name:

Designation:
Place:
Date:

Name:
Designation:
Place:
Date:

Accepted

Specimen signatures of attorney attested

.....

(Signature)

.....

.....

(Signature of Notary Public)

.....

**(Name, Designation and Address
of the Attorney)**

Place:

Date:

Notes:

1. The mode of execution of the power of attorney should be in accordance with the procedure, if any, laid down by the applicable law and the charter documents of the executant(s) and when it is so required, the same should be under common seal of the executant affixed in accordance with the applicable procedure. Further, the person whose signatures are to be provided on the power of attorney shall be duly authorized by the executant(s) in this regard.
2. Also, wherever required, the executant(s) should submit for verification the extract of the charter documents and documents such as a Board resolution / power of attorney, in favour of the Person executing this power of attorney for delegation of power hereunder on behalf of the executant(s).
3. In case of foreign Bidders, refer to clause 2.5.6 (p)

ANNEXURE 5 - FORMAT FOR BIDDER'S COMPOSITION AND OWNERSHIP STRUCTURE

1. Corporate Details:

Please provide the following information for the Bidder. If the Bidder is a Consortium, please provide this information for each Member including the Lead Member:

a. Company's Name, Address, and Nationality:

Name:

Address:

Website Address:

Country of Origin:

b. Year Organized:

c. Company's Business Activities:

d. Status as a Bidder:

- i. Bidding Company
- ii. Lead Member of the Bidding Consortium
- iii. Member of the Bidding Consortium

Note: tick the applicable serial number

e. Company's Local Address in India (if applicable):

.....

f. Name of the Authorized Signatory:

g. Telephone Number:

h. Email Address:

i. Telefax Number:

j. Please provide the following documents:

- i. Copy of the Memorandum and Articles of Association and certificate of incorporation or other equivalent organizational document (as applicable), including their amendments, certified by the Company Secretary as **Attachment 1** for Bidding Company / each Member of Bidding Consortium including Lead Member.

- ii. Authority letter (as per format for authorization given below) in favour of BPC from the Bidder/every Member of the Consortium authorizing BPC to seek reference from their respective bankers & others as **Attachment 2** as per Clause 2.1.6 of the RFP.

2. Details of Ownership Structure:

Equity holding of Bidding Company/ each Member of Bidding Consortium including Lead Member owning 10% or more of total paid up equity.

Name of the Bidding Company / Consortium Member:

Status of equity holding as on

Name of the Equity Holder	Type and No. of Shares owned	Extent of Voting Control (%)
1.		
2.		
3.		
4.		
5.		
6.		
7.		
8.		
....		

Notes:

- 1. The above table is to be filled in separately for each Consortium Member.
- 2. Status of equity holding should be provided not earlier than thirty (30) days prior to Bid Deadline.

For and on behalf of Bidding Company / Lead Member of the Bidding Consortium

M/s.....

.....
(Signature of authorized representative)

Name:

Designation:

.....
(Stamp)

Date:

Place:

FORMAT FOR AUTHORISATION

(In case of Bidding Consortium, to be given separately by each Member)
(On Non – judicial stamp paper duly attested by notary public. Foreign companies submitting bids are required to follow the applicable law in their country)

The undersigned hereby authorize(s) and request(s) all our Bankers, including its subsidiaries and branches, any person, firm, corporation or authority to furnish pertinent information deemed necessary and requested by REC Power Development and Consultancy Limited to verify our Bid for selection of Bidder as Transmission Service Provider to establish Inter-State Transmission system for “**Western Region Network Expansion scheme in Kallam area of Maharashtra**” through tariff based competitive bidding process or regarding our project development experience, financial standing and general reputation.

For and on behalf of M/s..... (Insert Name of Bidding Company or Member of the Consortium)

.....
(Signature)

Name of Authorized Signatory:

(Signature and Name of the authorized signatory of the Company)

Place:

Date:

.....
(Company rubber stamp/seal)

.....
(Signature of Notary Public)

Place:

Date:

ANNEXURE 6 - FORMAT FOR CONSORTIUM AGREEMENT

(To be on non-judicial stamp paper of appropriate value as per Stamp Act relevant to place of execution. Foreign companies submitting bids are required to follow the applicable law in their country)

THIS CONSORTIUM AGREEMENT executed on this..... day ofTwo thousand.....between M/s....., a company incorporated under the laws of and having its Registered Office at (hereinafter called the "Party 1", which expression shall include its successors, executors and permitted assigns) and M/s.....a Company incorporated under the laws of and having its Registered Office at (hereinafter called the "Party n", which expression shall include its successors, executors and permitted assigns) and for the purpose of submitting the Bid, acquisition of Kallam Transco Limited (in case of award) and entering into other Agreement(s) as specified in the RFP (hereinafter referred to as "Agreements") as may be entered into with the Nodal Agency.

WHEREAS, the BPC had invited Bid in response to RFP issued to (insert the name of purchaser of RFP) for selection of the bidder as the Transmission Service Provider to establish Inter-State Transmission System for **"Western Region Network Expansion scheme in Kallam area of Maharashtra"**.

AND WHEREAS, Clause 2.2.4 of the RFP document stipulates that the Bidders qualifying on the strength of a Bidding Consortium will have to submit a legally enforceable Consortium Agreement in a format specified in the RFP document wherein the Consortium Members have to commit equity of a specific percentage in the Project.

AND WHEREAS, Clause 2.2.4 of the RFP document also stipulates that the Bidding Consortium shall provide along with the Bid, a Consortium Agreement as per prescribed format whereby the Consortium Members undertake to be liable for raising the required funds for its respective equity investment commitment as specified in Consortium Agreement.

NOW THEREFORE, THIS INDENTURE WITNESSTH AS UNDER:

In consideration of the above premises and agreement all the parties in this Consortium do hereby mutually agree as follows:

1. In consideration of the selection of the Consortium as the selected bidder by the BPC, we the Members of the Consortium and parties to the Consortium Agreement do hereby unequivocally agree that M/s..... (Insert name of the Lead Member), shall act as the Lead Member as defined in the RFP for self and agent for and on behalf of,,, (the names of all the other Members of the Consortium to be filled in here).
2. The Lead Member is hereby authorized by the Members of Consortium and parties to the Consortium Agreement to bind the Consortium and receive instructions for and on behalf of the Members.
3. Notwithstanding anything contrary contained in this Consortium Agreement, the Lead Member shall always be liable for the equity investment obligations of all the Consortium

Members, i.e., for both its own equity contribution as well as the equity contribution of other Members.

4. The Lead Member shall be liable and responsible for ensuring the individual and collective commitment of each of the Members of the Consortium in discharging all their respective equity obligations. Each Consortium Member further undertakes to be individually liable for the performance of its part of the obligations without in any way limiting the scope of collective liability envisaged in this agreement.
5. Subject to the terms of this agreement, the share of each Member of the Consortium in the “issued equity share capital of the project company” shall be in the following proportion: (if applicable)

Name	Percentage of equity holding in the Project
Party 1
.....
Party n
Total	100%

[**Note:** The percentage equity holding for any Consortium Member in the Project cannot be zero in the above table]

6. The Lead Member shall inter alia undertake full responsibility for liaising with lenders and mobilizing debt resources for the Project and achieving financial closure.
7. In case of any breach of any of the equity investment commitment by any of the Consortium Members, the Lead Member shall be liable for the consequences thereof.
8. Except as specified in the Agreement, it is agreed that sharing of responsibilities as aforesaid and equity investment obligations thereto shall not in any way be a limitation of responsibility of the Lead Member under these presents.
9. It is further specifically agreed that the financial liability for equity contribution of Lead Member shall, not be limited in any way so as to restrict or limit its liabilities. The Lead Member shall be liable irrespective of their scope of work or financial commitments.
10. It is expressly understood and agreed between the Members that the responsibilities and obligations of each of the Members shall be as delineated as annexed hereto as **Appendix-I**, forming integral part of this Agreement. It is further agreed by the Members that the above sharing of responsibilities and obligations shall not in any way be a limitation of joint and several responsibilities and liabilities of the Members, with regards to all matters relating to the Project.
11. It is clearly agreed that the Lead Member shall ensure performance under the Agreements and if one or more Consortium Members fail to perform its /their respective obligations under the Agreement(s), the same shall be deemed to be a default by all the Consortium Members.
12. This Consortium Agreement shall be construed and interpreted in accordance with the Laws of India and courts at **Delhi** alone shall have the exclusive jurisdiction in all matters relating thereto and arising there under.

- 13. It is hereby agreed that, the Lead Member shall furnish the bid bond, as stipulated in the RFP, on behalf of the Consortium Members.
- 14. It is hereby agreed that in case of selection of Bidding Consortium as the selected bidder, the parties to this Consortium Agreement do hereby agree that they shall furnish the contract performance guarantee on behalf of the TSP in favor of the Nodal Agency, as stipulated in the RFP and Transmission Service Agreement.
- 15. It is further expressly agreed that the Consortium Agreement shall be irrevocable and shall form an integral part of the RFP Project Document and shall remain valid till the execution of the Share Purchase Agreement, unless expressly agreed to the contrary by the Nodal Agency. Over the term of the Transmission Service Agreement, Central Electricity Regulatory Commission (Sharing of Inter-State Transmission Charges and Losses) Regulations as amended from time to time shall apply on the Consortium Members.
- 16. The Lead Member is authorized and shall be fully responsible for the accuracy and veracity of the representations and information submitted by the Consortium Members respectively from time to time in response to the RFP and for the purposes of the Project.
- 17. It is hereby expressly agreed between the parties to this Consortium Agreement that neither party shall assign or delegate its rights, duties or obligations under this Agreement except with the prior written consent of the Nodal Agency.

THIS CONSORTIUM AGREEMENT:

- a. has been duly executed and delivered on behalf of each party hereto and constitutes the legal, valid, binding and enforceable obligation of each such party,
- b. sets forth the entire understanding of the parties hereto with respect to the subject matter hereof;
- c. may not be amended or modified except in writing signed by each of the parties and with prior written consent of the Nodal Agency.

IN WITNESS WHEREOF, the parties to the Consortium Agreement have, through their authorized representatives, executed these present on the Day, Month and Year first mentioned above.

For and on behalf of Consortium Member 1 (Party 1)
M/s.....

.....
(Signature of authorized signatory)

Name:
Designation:
Place:
Date:

For and on behalf of Consortium Member n (Party n)
M/s.....

.....
(Signature of authorized signatory)

Name:
Designation:
Place:
Date:

Attested:

.....
(Signature)
(Notary Public)

Place:
Date:

Note: In case of foreign Bidders, refer to clause 2.5.6 (p)

Appendix 1 to the Consortium Agreement:

Name of the Consortium Member	Responsibilities under the Consortium Agreement
M/s (Party 1)	
M/s	
M/s (Party n)	

ANNEXURE 7 A - FORMAT FOR QUALIFICATION REQUIREMENT

A. NET WORTH

To,
Chief Executive Officer,
REC Power Development and Consultancy Limited
(A wholly owned subsidiary of REC Limited)
REC Corporate Head Quarter,
D Block, Plot No. I – 4,
Sec – 29 Gurugram – 122 001

Dear Sir,

Sub: Bid for selection of Bidder as Transmission Service Provider to establish Inter-State Transmission System for “Western Region Network Expansion scheme in Kallam area of Maharashtra” through tariff based competitive bidding process

1. [Note: Applicable in case of Bidding Company]

We certify that the Financially Evaluated Entity(ies) had a Networth of Rs. Crore or equivalent USD* computed as per instructions in this RFP based on unconsolidated audited annual accounts (refer Note-2 below) of any of the last three (3) financial years as provided in Clause 2.2.3, immediately preceding the Bid Deadline. Also, the Networth of any of the last three (3) financial years is not negative.

Name of Financially Evaluated Entity(ies)	Relationship with Bidding Company**	Financial Year	Networth (Rs. Crore)
1.			
2.			
3.			
....			
Total Network			

*Equivalent USD shall be calculated as per provisions of Clause 3.4.1.

** The column for “Relationship with Bidding Company” is to be filled in only in case financial capability of Parent/Affiliate has been used for meeting Qualification Requirements.

2. [Note: Applicable in case of Bidding Consortium]

We certify that the Financially Evaluated Entity(ies) had a minimum Networth of Rs. Crore or equivalent USD* computed as per instructions in the RFP and based on unconsolidated audited annual accounts (refer Note-2 below) of any of the last three (3) financial years as provided in Clause 2.2.3, immediately preceding the Bid Deadline. Also, the Networth of any of the last three (3) financial years is not negative.

Name of Consortium Member	Equity Commitment in the Project (%)	Networth of Member (Rs. Crore)	Networth Requirement to be met by Member in proportion to the Equity Commitment (Rs. Crore)	Whether the Member meets the Networth Requirement
(1)	(2)	(3) (As per table below)	(4) = (2 x Total Networth requirement for the Project)	(5)
1.				Yes / No
2.				Yes / No
..				Yes / No
Total Networth for financial requirement				

Member – I (Lead Member)

[Note: Similar particulars for each Member of the Consortium is to be furnished, duly certified by the Member's Statutory Auditors]

- i. Name of Member:
- ii. Total Networth requirement: Rs Crore
- iii. Percentage of equity commitment for the Project by the Member:%
- iv. Networth requirement for the Member***: Rs Crore
- v. Financial year considered for the Member:

Name of Financially Evaluated Entity(ies)	Relationship** with Member of Consortium	Financial Year	Networth (Rs. Crore)
1.			
2.			
3.			
Total Networth			

* Equivalent USD shall be calculated as per provisions of Clause 3.4.1;

** The column for "Relationship with Member of Consortium" is to be filled in only in case the financial capability of Parent / Affiliate has been used for meeting Qualification Requirements;

*** Networth requirement to be met by Member should be in proportion to the equity commitment of the Member for the Project.

Yours faithfully

.....
(Signature and name of the authorized signatory of the Company and Stamp)

Name:
Date:
Place:

.....
(Signature and Stamp of statutory Auditors of Bidding Company / each Member of Consortium)

Name:
Date:
Place:

Date:

Notes:

1. Along with the above format, in a separate sheet, please provide details of computation of Networth of last three (3) financial years duly certified by Statutory Auditor.
2. Audited consolidated annual accounts of the Bidder may be used for the purpose of financial criteria provided the Bidder has at least 26% equity in each company whose accounts are merged in the audited consolidated accounts and provided further that the financial capability of such companies (of which accounts are being merged in the consolidated accounts) shall not be considered again for the purpose of evaluation of the Bid.
3. In case Bidder or a Member of Consortium takes recourse to its Parent/Affiliate for meeting technical / financial requirements, then the financial years considered for such purpose should be same for the Bidder / Member of Consortium and their respective Parent / Affiliate.

ANNEXURE 7B - FORMAT FOR TECHNICAL REQUIREMENT

To,

**Chief Executive Officer,
REC Power Development and Consultancy Limited
(A wholly owned subsidiary of REC Limited)
REC Corporate Head Quarter,
D Block, Plot No. I – 4,
Sec – 29 Gurugram – 122 001**

Dear Sir,

Sub: Bid for selection of Bidder as Transmission Service Provider to establish Inter-State Transmission System for “Western Region Network Expansion scheme in Kallam area of Maharashtra” through tariff based competitive bidding process

1. To be used by Bidder using the development experience in infrastructure sector

We certify that M/s. (Insert name of Technically Evaluated Entity(ies)) have experience of development of projects in the Infrastructure sector in the last five (5) years whose aggregate capital expenditure is Rs. Crore or equivalent USD*. We further certify that the capital expenditure of any single project considered for meeting the technical Qualification Requirement is not less than Rs. Crore or equivalent USD*. For this purpose, capital expenditure incurred on projects which have been either wholly completed / commissioned or partly completed projects put under commercial operation and for which operation has commenced till at least seven (7) days prior to the Bid Deadline has been considered.

The project(s) considered for the purpose of technical experience (as per table given below) have been executed and owned to the extent as indicated in the table below (to be atleast twenty – six percent (26%)) by the Bidding Company / Lead Member of the Consortium / our Parent / our Affiliate(s) [strike off whichever is not applicable] on operation of the projects.

This technical requirement has been calculated as per the instructions provided in the RFP on the basis of following projects:

Name of Company (which has executed the project at (3)) whose technical capability has been used for Qualification Requirement	Relationship** with Bidding Company / Lead Member	Project name	Nature of Project (BOOT, BOT, BOOM, DBFOT etc.)	Relevant Infrastructure sector	Date of Financial Closure of the Project (in DD / MM / YYYY)	Date of Completion / Commissioning / Commercial Operation of partly completed projects	Project cost (Rs. Crore)	Percentage Equity Holding of Company at (1) in Completed project(s)
(1)	(2)	(3)	(4)	(5)	(6)	(7)	(8)	(9)
.....	 (Project 1)						
.....							
Total (Rs. Crore)								

* Equivalent USD shall be calculated as per provisions of Clause ____

- ** The column for “Relationship with Bidding Company / Lead Member” is to be filled in only in case technical capability of Parent/Affiliate has been used for meeting Qualification Requirements.

We further certify that the Company(ies) as indicated in column (1) of the above table, whose technical capability has / have been used for meeting the qualification requirement, has / have held shareholding respectively of atleast twenty – six percent (26%) from the date of financial closure till the date of commissioning / completion of the above project(s).

2. To be used by Bidder using construction experience in infrastructure sector.

We certify that M/s. (Insert name of Technically Evaluated Entity(ies)) have received aggregate payments not less than Rs. Crore or equivalent USD (calculated as per provisions in Clause 3.4.1) from its client(s) for construction works fully completed during the last 5(five) financial years. We further certify that the payment received from each project shall not be less than Rs. Crore or equivalent USD (calculated as per provisions in Clause 3.4.1). For this purpose, payments received on projects that have been commissioned/completed at least seven (7) days prior to the Bid Deadline shall be considered. Further only the payments (gross) actually received, during such 5 (five) financial years shall qualify for purposes of computing the technical capacity.

We also confirm that construction works does not include cost of land supply of goods or equipment except when such goods or equipment form part of a turn-key construction contract/ EPC contract for the project.

This technical requirement has been calculated as per the instructions provided in the RFP on the basis of following projects:

Name of Company (which has executed the project at (3)) whose technical capability has been used for Qualification Requirement	Relationship** with Bidding Company / Lead Member	Project name	Nature of Project (EPC, Turnkey etc)	Relevant Infrastructure sector	Date of award of contract (in dd/mm/yy)	Date of Completion / Commissioning	Payment received (Rs. Crore)
(1)	(2)	(3)	(4)	(5)	(6)	(7)	(8)
.....	 Project 1					
.....						
.....						
Total (Rs. Crore)							

Yours faithfully

.....
(Signature and name of the authorized signatory of the Company and stamp)

Name:
Date:
Place:

.....
(Signature and Stamp of statutory Auditors of Bidding Company/ Lead Member of Consortium)

Name:
Date:
Place:

Date:

Notes:

1. Along with the above format, in a separate sheet, please provide details of computation of capital expenditure of projects duly certified by Statutory Auditor of the project company. In addition, the Statutory Auditor of the project company should also certify that the capital expenditure of projects commissioned or completed 7 days prior to Bid Deadline has been capitalized in the books of accounts.

Additionally, in case construction experience is used, a certificate(s) from the statutory auditors stating the payments received and the concerned client(s) stating the works commissioned during the past 5 years in respect of the projects specified above. In case a particular job/ contract has been jointly executed by the Bidder (as part of a consortium), it should further support its claim for the share in work done for that particular job/ contract by producing a certificate from its statutory auditor or the client.

2. In case the accounts for the financial year in which the project claimed for meeting qualification requirement has been commissioned are not audited, the Bidder shall give declaration in this regard duly certified by its statutory auditor. In such a case, Bidder shall provide details of computation of capital expenditure of such project(s) duly certified by Statutory Auditor of the project company and the Statutory Auditor of the project company should also certify that the capital expenditure of projects commissioned or completed shall be capitalized in the books of accounts upon finalization.
3. The unconsolidated audited annual accounts of both the TEE and the Bidding Company / Lead Member for the respective financial years (financial years in which financial closure was achieved to the financial year in which the said project was completed / commissioned) should be submitted.

**ANNEXURE 7C - FORMAT FOR TECHNICAL & FINANCIAL REQUIREMENT –
RELATIONSHIP & DETAILS OF EQUITY SHAREHOLDING**

[To be filled by Bidding Company / each Member of the Bidding Consortium including Lead Member if credentials of Parent and / or Affiliates have been used by them]

To,

**Chief Executive Officer,
REC Power Development and Consultancy Limited
(A wholly owned subsidiary of REC Limited)
REC Corporate Head Quarter,
D Block, Plot No. I – 4,
Sec – 29 Gurugram – 122 001**

Dear Sir,

Sub: Bid for selection of Bidder as Transmission Service Provider to establish Inter-State Transmission System for “Western Region Network Expansion scheme in Kallam area of Maharashtra” through tariff based competitive bidding process

We certify that M/s. (insert name of the **Bidding Company / Consortium Members**) have considered the technical and financial capability of its Parent and / or Affiliates, for the purpose of meeting Qualification Requirements as per the instructions provided in the RFP. The name of Parent and / or Affiliate, nature of relationship(s) with such Parent and / or Affiliate and details of equity holding are as follows:

Name of Company whose credentials considered	Type of credentials considered (technical and / or financial)	Relationship with Bidding Company / Consortium Member (Parent / Affiliate)	Details of equity shareholding (refer notes below)
Company 1			
.....			
.....			
.....			
.....			

NOTES:

- i. In case of Parent, the equity holding of the Parent in the Bidding Company / Member of the Bidding Consortium, including the Lead Member of the Consortium, need to be specified.
- ii. In case of Affiliate under direct control of Bidder, the equity holding of the Bidding Company / Member of the Bidding Consortium, including the Lead Member of the Consortium in the Affiliate, needs to be specified.
- iii. In case of Affiliate under common control of Parent, the equity holding of the Parent in the Affiliate of the Bidding Company / Member of the Bidding Consortium, including the Lead Member of the Consortium, needs to be specified.

- iv. Relationship of Parent / Affiliate with Bidding Company / Member of Consortium to be at the most seven (7) days prior to the Bid Deadline (as per Clause 2.1.4 of RFP)

Yours faithfully

.....

(Signature and name of the authorized signatory of the Company and stamp)

Name:

Date:

Place:

.....

(Signature and Stamp of statutory Auditors of Bidding Company / each Member of Bidding Consortium)

Name:

Date:

Place:

Date:

**ANNEXURE 7D - ADDITIONAL INFORMATION FOR VERIFICATION OF
FINANCIAL AND TECHNICAL CAPABILITIES OF BIDDERS.**

.....
(Name of Bidder (Bidding Company/ Bidding Consortium or Technically/Financially Evaluated Entity(ies))

(Note: In case of Consortium, details to be filled in by Lead Member for each Member of the Consortium including the Lead Member and in case of the qualification requirements of Technically / Financially Evaluated Entity(ies) being used, to be filled by each of such entity(ies)

i. Financial capability (Attachment 1):

1. Bidders shall attach unconsolidated / consolidated audited annual accounts, statements, as the case may be, (refer Clause 2.1.3) for the last three (3) financial years as Attachment 1. Such unconsolidated audited annual accounts shall include a Balance Sheet, Profit and Loss Account, Auditors Report and profit appropriation account.

ii. Technical capability (Attachment 2):

- a. This attachment shall include details of projects completed/commissioned or partly completed projects for which commercial operation has commenced to be considered for the purpose of meeting Qualification Requirements.

1. To be used by Bidder using development experience in infrastructure sector

Particulars	Year 1	Year 2	Year 3	Year 4	Year 5
Name(s) of project(s) from Infrastructure sectors					
Location(s) including country(s) where project was set up					
Nature of Project					
Voltage level (if any)					
Capital cost of project(s) Rs. in Crore					
*Status of the project					
% of equity owned in the project(s)					

***Note 1:** Date of completion/commissioning/commercial operation to be mentioned

Note 2: For each project listed in the table, the Bidder shall furnish an executive summary including the following information:

- Project model, i.e., BOO, BOOT, BOOM;
- Debt financing and equity raised and provided by Bidder/Bidder's Parent/Bidder's Affiliate for the project, including names of lenders and investors;
- Size and type of installation;

- Technical data/information on major equipment installed
- Description of role performed by the Bidder/Bidder's Parent/Bidder's Affiliate on the project
- Clearances taken by the Bidder/Bidder's Parent/Bidder's Affiliate including but limited to right-of-way (RoW), forest clearance and other statutory / Govt. clearances.
- Cost data (breakdown of major components)
- Name of EPC and/or other major contractor
- Construction time for the project
- Names, addresses and contact numbers of owners of the projects
- Operating reliability over the past five (5) years or since date of commercial operation
- Operating environmental compliance history
- Names of supervisory entities or consultant, if any
- Date of commercial operation
- Total duration of operation

2. To be used by Bidder using construction experience in infrastructure sector

Particulars	Year 1	Year 2	Year 3	Year 4	Year 5
Name(s) of project(s) from Infrastructure sectors					
Location(s) including country(s) where project was set up					
Nature of Project					
Voltage level (if any)					
Revenue received Rs. in Crore					
*Status of the project					
% of equity owned in the project(s)					

***Note 1:** Date of completion/commissioning/commercial operation to be mentioned

Note 2: For each project listed in the table, the Bidder shall furnish an executive summary including the following information:

- Project model, i.e., EPC, Turnkey;
- Size and type of installation;
- Technical data/information on major equipment installed
- Description of role performed by the Bidder/Bidder's Parent/Bidder's Affiliate on the project
- Cost data (breakdown of major components)
- Name of sub-contractor
- Construction time for the project
- Names, addresses and contact numbers of owners of the projects
- Operating reliability over the past five (5) years or since date of commercial operation
- Operating environmental compliance history
- Names of supervisory entities or consultant, if any
- Date of commercial operation
- Total duration of operation

iii. Attachment-3:

- a. For each project listed in Attachment 2 above, certificates of final acceptance and/or certificates of good operating performance duly issued by owners for the project and the same shall be certified as true by authorized signatory of the Bidding Company or the Lead Member of Consortium). In case the project listed in Attachment 2 is under BOOT / DBFOT mechanism, the certificates of final acceptance and/or certificates of good operating performance must be issued by the authority / independent engineer of the project as defined in the respective project agreement.

For and on behalf of Bidding Company/Consortium

M/s.....

.....
(Signature of authorized signatory)

Name:

Designation:

Date:

Place:

ANNEXURE 8 -UNDERTAKING AND DETAILS OF EQUITY INVESTMENT**Format 1: Bidders' Undertakings****[On the Letter Head of the Bidding Company/Lead Member of Bidding Consortium]****Date:****To,**

**Chief Executive Officer,
 REC Power Development and Consultancy Limited
 (A wholly owned subsidiary of REC Limited)
 REC Corporate Head Quarter,
 D Block, Plot No. I – 4,
 Sec – 29 Gurugram – 122 001**

Dear Sir,

Sub: Bidders' Undertakings in respect of Bid for selection of Bidder as TSP to establish Inter-State transmission system for “Western Region Network Expansion scheme in Kallam area of Maharashtra”

We hereby undertake on our own behalf and on behalf of the TSP, that if selected as the Successful Bidder for the Project:

1. The Project shall comply with all the relevant electricity laws, codes, regulations, standards and Prudent Utility Practices, environment laws and relevant technical, operational and safety standards, and we shall execute any agreements that may be required to be executed as per law in this regard.
2. We confirm that the Project shall also comply with the standards and codes as per Clause 1.6.1.2 of the RFP and the TSP shall comply with the provisions contained in the Central Electricity Regulatory Commission Grant of Connectivity, Long-term Access and Medium-term Open Access in inter-state Transmission and related matters Open Access) Regulations, 2009.
3. We give our unconditional acceptance to the RFP dated 13.10.2023 issued by the BPC and the RFP Project Documents, as amended, and undertake to ensure that the TSP shall execute all the RFP Project Documents, as per the provisions of this RFP.
4. We have submitted the Bid on the terms and conditions contained in the RFP and the RFP Project Documents. Further, the Financial Bid submitted by us is strictly as per the format provided in Annexure 21 of the RFP, without mentioning any deviations, conditions, assumptions or notes in the said Annexure.
5. Our Bid is valid up to the period required under Clause 2.8 of the RFP.
6. Our Bid has been duly signed by authorized signatory and stamped in the manner and to the extent indicated in this RFP and the power of attorney / Board resolution in requisite format as per RFP has been enclosed with this undertaking.

7. We have assumed that if we are selected as the Successful Bidder, the provisions of the Consortium Agreement, to the extent and only in relation to equity lock in and our liability thereof shall get modified to give effect to the provisions of Clause 2.5.8 of this RFP and Article 18.1 of the Transmission Service Agreement. (*Note: This is applicable only in case of a Bidding Consortium*)
8. We confirm that our Bid meets the Scheduled COD of each transmission Element and the Project as specified below:

Sl. No.	Name of the Transmission Element	Scheduled COD in months from Effective Date	Percentage of Quoted Transmission Charges recoverable on Scheduled COD of the Element of the Project	Element(s) which are pre-required for declaring the commercial operation (COD) of the respective Element
1.	LILO of both circuits of Parli(M) – Karjat(M)/Lonikand-II (M) 400 kV D/c line (twin moose) at Kallam PS	18 months from date of SPV acquisition	100%	All Elements are required to be commissioned simultaneously as their utilization is dependent on commissioning of each other.
2.	4 Nos. 400 kV line bays at Kallam PS for LILO of both circuits of Parli(M) – Karjat(M)/Lonikand-II(M) 400 kV D/c line (twin moose) at Kallam PS			
3.	63 MVAR, 420 kV switchable line reactor (with NGR bypassing arrangement) on each ckt at Kallam PS end of Karjat – Kallam 400 kV D/c line (~140km.)			

We agree that the payment of Transmission Charges for any Element irrespective of its successful commissioning on or before its Scheduled COD shall only be considered after the successful commissioning of Element(s) which are pre - required for declaring the commercial operation of such Element as mentioned in the above table.

Scheduled COD for the Project: 18 months from the date of SPV Transfer.

9. We confirm that our Financial Bid conforms to all the conditions mentioned in this RFP, and in particular, we confirm that:
- Financial Bid in the prescribed format of Annexure 21 has been submitted duly signed by the authorized signatory.
 - Financial Bid is unconditional.

- c. Only one Financial Bid has been submitted.
10. We have neither made any statement nor provided any information in this Bid, which to the best of our knowledge is materially inaccurate or misleading. Further, all the confirmations, declarations and representations made in our Bid are true and accurate. In case this is found to be incorrect after our acquisition of Kallam Transco Limited, pursuant to our selection as Selected Bidder, we agree that the same would be treated as a TSP's Event of Default under Transmission Service Agreement, and relevant provisions of Transmission Service Agreement shall apply.
11. We confirm that there are no litigations or other disputes against us which materially affect our ability to fulfill our obligations with regard to the Project as per the terms of RFP Project Documents.
12. Power of attorney/ Board resolution as per Clause 2.5.2 is enclosed.

Signature and name of the authorized signatory of the Company and stamp of Bidding Company or Lead member of Consortium

Note:

1. In case of foreign Bidders, refer to clause 2.5.6 (p)

Format 2: Details of equity investment in Project

1.1.a Name of the Bidding Company/ Bidding Consortium:

1.1.b Name of the Lead Member in the case of a Bidding Consortium:

1.2 Investment details of the Bidding Company/Member of the Bidding Consortium investing in Kallam Transco Limited as per Clause 2.5.8.2.

S. No.	Name of the Bidding Company/ Member in case of a Bidding Consortium	Name of the Company investing in the equity of the Kallam Transco Limited	Relationship with Bidding Company /Member of the Bidding Consortium	% of equity participation in the Kallam Transco Limited
(1)	(2)	(3)	(4)	(5)
TOTAL				100%

* In case the Bidder proposes to invest through its Affiliate(s) / Parent Company / Ultimate Parent Company, the Bidder shall declare shareholding pattern of such Affiliate(s) / Parent Company / Ultimate Parent Company and provide documentary evidence to demonstrate relationship between the Bidder and the Affiliate(s) / Parent Company / Ultimate Parent Company. These documentary evidences could be, but not limited to, demat account statement(s) / Registrar of Companies' (ROC) certification / share registry book, etc duly certified by Company Secretary.

Members of the Consortium or the Bidding Company making investment in the equity of the Kallam Transco Limited themselves to fill in their own names in the column (3)

Signature and Name of authorized signatory in whose name power of attorney has been issued

Signature of authorized signatory

Name:

Designation:

Date.....

Company rubber stamp

ANNEXURE 9 -AUTHORISATION FROM PARENT / AFFILIATE OF BIDDING COMPANY / MEMBER OF BIDDING CONSORTIUM WHOSE TECHNICAL / FINANCIAL CAPABILITY HAS BEEN USED BY THE BIDDING COMPANY / MEMBER OF BIDDING CONSORTIUM.

[On the Letter Head of the Parent /Affiliate]

Name:
 Full Address:
 Telephone No.:
 E-mail address:
 Fax / No.:

To

**Chief Executive Officer,
 REC Power Development and Consultancy Limited
 (A wholly owned subsidiary of REC Limited)
 REC Corporate Head Quarter,
 D Block, Plot No. I – 4,
 Sec – 29 Gurugram – 122 001**

Dear Sir,

**Sub: Authorization for use of Technical / Financial Capability of M/s.....
 (Insert name of Parent / Affiliate) by M/s (Insert name of Bidding
 Company / Member of Bidding Consortium).**

We refer to the RFP dated 13.10.2023 ('RFP') issued by you for selection of Bidder as Transmission Service Provider for establishing the Inter-State Transmission System for "Western Region Network Expansion scheme in Kallam area of Maharashtra".

We confirm that M/s. (Insert name of Bidding Company/ Consortium Member) has been authorized by us to use our technical and/or financial capability [strikeout whichever is not applicable] for meeting the Qualification Requirements for "Western Region Network Expansion scheme in Kallam area of Maharashtra".

We have carefully read and examined in detail the RFP including in particular, Clause 2.1.4 of the RFP, and we are also submitting legally binding undertaking supported by a board resolution that all the equity investment obligations of M/s..... (Insert Name of Bidding Company / Consortium Member), shall be deemed to be our equity investment obligations and in the event of any default the same shall be met by us.

For and on behalf of M/s..... (Insert Name of Parent / Affiliate)

.....
(Signature and Name of the authorized signatory of the Company and stamp)

Name:
 Date:

Place:

Notes:

1. The above undertaking can be furnished by Ultimate Parent of Technically Evaluated Entity or Financially Evaluated Entity, as the case maybe, if legally binding undertaking is also furnished by the Ultimate Parent on behalf of such Financially Evaluated Entity/Technically Evaluated Entity.

**ANNEXURE 10- FORMAT OF UNDERTAKING BY TECHNICALLY / FINANCIALLY
EVALUATED ENTITY / ULTIMATE PARENT COMPANY**

**[On the Letter Head of the Technically / Financially Evaluated Entity / Ultimate Parent
Company]**

Name:

Full Address:

Telephone No.:

E-mail address:

Fax/No.:

To:

**Chief Executive Officer,
REC Power Development and Consultancy Limited
(A wholly owned subsidiary of REC Limited)
REC Corporate Head Quarter,
D Block, Plot No. I – 4,
Sec – 29 Gurugram – 122 001**

Sub: Undertaking for equity investment

Dear Sir,

We refer to the Request for Proposal dated _____ ('RFP') issued by you regarding setting up of Inter-State transmission system for “**Western Region Network Expansion scheme in Kallam area of Maharashtra**” Project on build, own, operate and transfer basis.

We have carefully read and examined in detail the RFP and the RFP Project Documents, including in particular, Clause 2.1.4 of the RFP and Clauses 2.5.2 and 2.5.8 of the RFP, regarding submission of an undertaking regarding the investment in the equity share capital of Kallam Transco Limited and provisions for minimum equity holding and equity lock-in. We have also noted the amount of the equity investment required to be made in Kallam Transco Limited by the [Insert the name of the Bidder or the Consortium Member] for the Project.

In view of the above, we hereby undertake to you and confirm that in the event of failure of[Insert the name of the Bidder or the Consortium Member] to invest in full or in part, in the equity share capital of Kallam Transco Limited as specified in the Bid, we shall invest the said amount not invested by.....[Insert the name of the Bidder or the Consortium Member] in Kallam Transco Limited by purchase of existing shares or subscribing to the new shares of Kallam Transco Limited, as stipulated by you.

We have attached hereto certified true copy of the Board resolution whereby the Board of Directors of our Company has approved issue of this Undertaking by the Company.

All the terms used herein but not defined, shall have the meaning as ascribed to the said terms under the RFP.

Certified as true.

.....
(Signature and Name of the authorized signatory of the Company and stamp)

Note:

1. Wherever required, extract of the charter documents and documents such as a Board resolution should be submitted for verification.

ANNEXURE 11 - FORMATS FOR BOARD RESOLUTIONS

Format 1**Format of the Board resolution for the Bidding Company / each Member of the Consortium / investing Affiliate / Parent Company / Ultimate Parent Company, where applicable**

[Reference Clause 2.5.2 of the RFP and the illustrations in Annexure 11A]

[**Note:** The following resolution no.1 needs to be passed by the Boards of each of the entity/(ies) making equity investment]

The Board, after discussion, at the duly convened Meeting on [Insert date], with the consent of all the Directors present and in compliance of the provisions of the Companies Act, 1956/2013, passed the following Resolution:

1. RESOLVED THAT pursuant to the provisions of the Companies Act, 1956 / Companies Act 2013 (as the case may be) and compliance thereof and as permitted under the Memorandum and Articles of Association of the company, approval of the Board be and is hereby accorded for investment of.....% (.....per cent) of the total equity share capital of Kallam Transco Limited representing the entire amount proposed to be invested by the company for the transmission system for “**Western Region Network Expansion scheme in Kallam area of Maharashtra**”, partly by acquisition of the existing equity shares from[Insert the name of the BPC] and / or partly by subscribing to the new equity shares, as per the terms of the RFP.

[**Note:** Equity investment obligations by the Bidding Company/each Member of the Bidding Consortium/investing Affiliate or Parent or Ultimate Parent should add up to 100%.]

[**Note:** In the event the Bidder is a Bidding Consortium, the following Board resolution no. 2 also needs to be passed by the Lead Member of the Bidding Consortium]

2. RESOLVED THAT approval of the Board be and is hereby accorded to contribute such further amount over and above the percentage (___%) limit to the extent becoming necessary towards the total equity share in the Kallam Transco Limited, obligatory on the part of the company pursuant to the terms and conditions contained in the Consortium Agreement dated executed by the company as per the provisions of the RFP.

[**Note:** In the event, the investing entity is an Affiliate or Parent or Ultimate Parent of the Bidder, the following Board resolution no. 3 shall also be passed by the Bidder]

3. FURTHER RESOLVED THAT the Board hereby acknowledges the Board Resolution(s) passed by the [Name of the Affiliate(s)/ Parent / Ultimate Parent] regarding the investment of (....%) of the equity share capital requirements of Kallam Transco Limited, which is to be invested by the[Name of the Affiliate(s)/ Parent / Ultimate Parent] for the Kallam Transco Limited, partly by acquisition of the existing equity shares from _____[Name of BPC] and partly by subscribing to the new equity shares, as per the terms of the RFP.

[**Note:** The following resolution no. 4 is to be provided by the Bidding Company / Lead Member of the Consortium only]

4. FURTHER RESOLVED THAT MR/MSbe and is hereby authorized to take all the steps required to be taken by the Company for submission of the Bid, including in particular, signing of the Bid, making changes thereto and submitting amended Bid, all the documents related to the Bid, certified copy of this Board resolution or letter or undertakings etc, required to be submitted to BPC as part of the Bid or such other documents as may be necessary in this regard.

Certified True Copy

Company rubber stamp to be affixed

[Notes:

- 1) This certified true copy should be submitted on the letterhead of the Company, signed by the Company Secretary or any Whole Time Director/ Manager (supported by a specific board resolution) of the Bidding Company or the Lead Member of Consortium.
- 2) The contents of the format may be suitably re-worded indicating the identity of the entity passing the resolution, i.e., the Bidding Company, each Member of the Bidding Consortium.
- 3) This format may be modified only to the limited extent required to comply with the local regulations and laws applicable to a foreign entity submitting this resolution. For example, reference to Companies Act 1956 / Companies Act 2013 (as the case may be) may be suitably modified to refer to the law applicable to the entity submitting the resolution. However, in such case, the foreign entity shall submit an unqualified opinion issued by the legal counsel of such foreign entity, stating that the Board resolutions are in compliance with the applicable laws of the respective jurisdictions of the issuing company and the authorizations granted therein are true and valid.]

Format 2**Format for the Board resolution of Technically / Financially Evaluated Entity / Ultimate Parent Company (in case credentials of such TEE/ FEE has been utilized by the Bidding Company or Bidding Consortium)**

The Board, after discussion, at the duly convened Meeting on [Insert date], with the consent of all the Directors present and in compliance of the provisions of the Companies Act, 1956 / 2013, passed the following Resolution:

RESOLVED THAT pursuant to the provisions of the Companies Act, 1956 / Companies Act, 2013 (as the case may be) and compliance thereof and as permitted under the Memorandum and Articles of Association of the company, approval of the Board be and is hereby accorded for issuing an Undertaking to the BPC, in the format specified in the RFP issued by the BPC, draft of which is attached hereto and initialed by the Chairman whereby the company undertakes to investpercent (... %) of the total equity share capital of Kallam Transco Limited representing the entire amount proposed to be invested by[insert the name of the Bidder or Member] for the said Project, in case of failure of[Insert the name of the Bidder or Member] to make such investment".

FURTHER RESOLVED THAT,be and is hereby authorized to take all the steps required to be taken by the Company, including in particular, signing the said Undertaking, submitting the same to the BPC through[Insert name of Bidding Company/Lead Member of the Consortium] of all the related documents, certified copy of this Board resolution or letter, undertakings etc, required to be submitted to BPC as part of the Bid or such other documents as may be necessary in this regard.

Certified True Copy**Company rubber stamp to be affixed****Note:**

1. This certified true copy should be submitted on the letterhead of the Company, signed by the Company Secretary or any Whole-time Director/Manager (supported by a specific board resolution) of Bidding Company or Lead Member of the Consortium.
2. The contents of the format may be suitably re-worded indicating the identity of the entity passing the resolution.
3. This format may be modified only to the limited extent required to comply with the local regulations and laws applicable to a foreign entity submitting this resolution. For example, reference to Companies Act 1956 / Companies Act 2013 (as the case may be) may be suitably modified to refer to the law applicable to the entity submitting the resolution. However, in such case, the foreign entity shall submit an unqualified opinion issued by the legal counsel of such foreign entity, stating that the Board resolutions are in compliance with the applicable laws of the respective jurisdictions of the issuing company and the authorizations granted therein are true and valid.

ANNEXURE 11A – ILLUSTRATION FOR APPLICABLE BOARD RESOLUTION REQUIREMENTS UNDER CLAUSE 2.5.2

Investor in the TSP	Entities (other than Bidder) whose credentials (financial and/or technical) used by the Bidder for meeting RFP criteria	Applicable Board Resolutions	Requirement of Undertaking (Annexure 10)
Bidder himself for 100% equity	None	a) Format 1 of Annexure 11 - Resolution: 1, 2 and 4 from the Bidder	None
Bidder himself for 100% equity	Affiliate and/or Parent Company and/or Ultimate Parent	<p>a) Format 1 of Annexure 11 - Resolution: 1, 2, and 4 from the Bidder</p> <p>b) Format 2 of Annexure 11 by either Technically/ Financially Evaluated Entity(ies) whose credentials have been used, or Ultimate Parent.</p> <p>Provided, if the Bidder himself is the Ultimate Parent, then Format 2 need not be provided.</p>	<p>Yes, by either Technically / Financially Evaluated Entity(ies) Affiliate(s) whose credentials have been used, or Ultimate Parent.</p> <p>Provided, if the Bidder himself is the Ultimate Parent, then the undertaking need not be provided.</p>
Bidder himself + others (Affiliate and/or Parent Company and/or Ultimate Parent) in aggregate holding 100% equity	None	<p>a) Format 1 of Annexure 11 - Resolution: 1,2, 3 and4 from the Bidder.</p> <p>b) Format 1 of Annexure 11 - Resolution: 1 from the Affiliate and /or Parent and /or Ultimate Parent investing in the equity</p>	None
Bidder himself + others (Affiliate and/or Parent Company and/or Ultimate Parent) in aggregate	Affiliate and/or Parent Company and/or Ultimate Parent	<p>a) Format 1 of Annexure 11 - Resolution: 1,2, 3 and 4 from the Bidder.</p> <p>b) Format 1 of Annexure 11 - Resolution: 1 from the Affiliate and/or Parent and/or Ultimate Parent investing in the equity</p>	Yes, by either Parent/ Affiliate(s) whose credentials have been used, or Ultimate Parent

Investor in the TSP	Entities (other than Bidder) whose credentials (financial and/or technical) used by the Bidder for meeting RFP criteria	Applicable Board Resolutions	Requirement of Undertaking (Annexure 10)
holding 100% equity		c) Format 2 of Annexure 11 by either Parent / Affiliate(s) whose credentials have been used and /or Ultimate Parent investing in the equity	

ANNEXURE 12 - FORMAT FOR ILLUSTRATION OF AFFILIATES

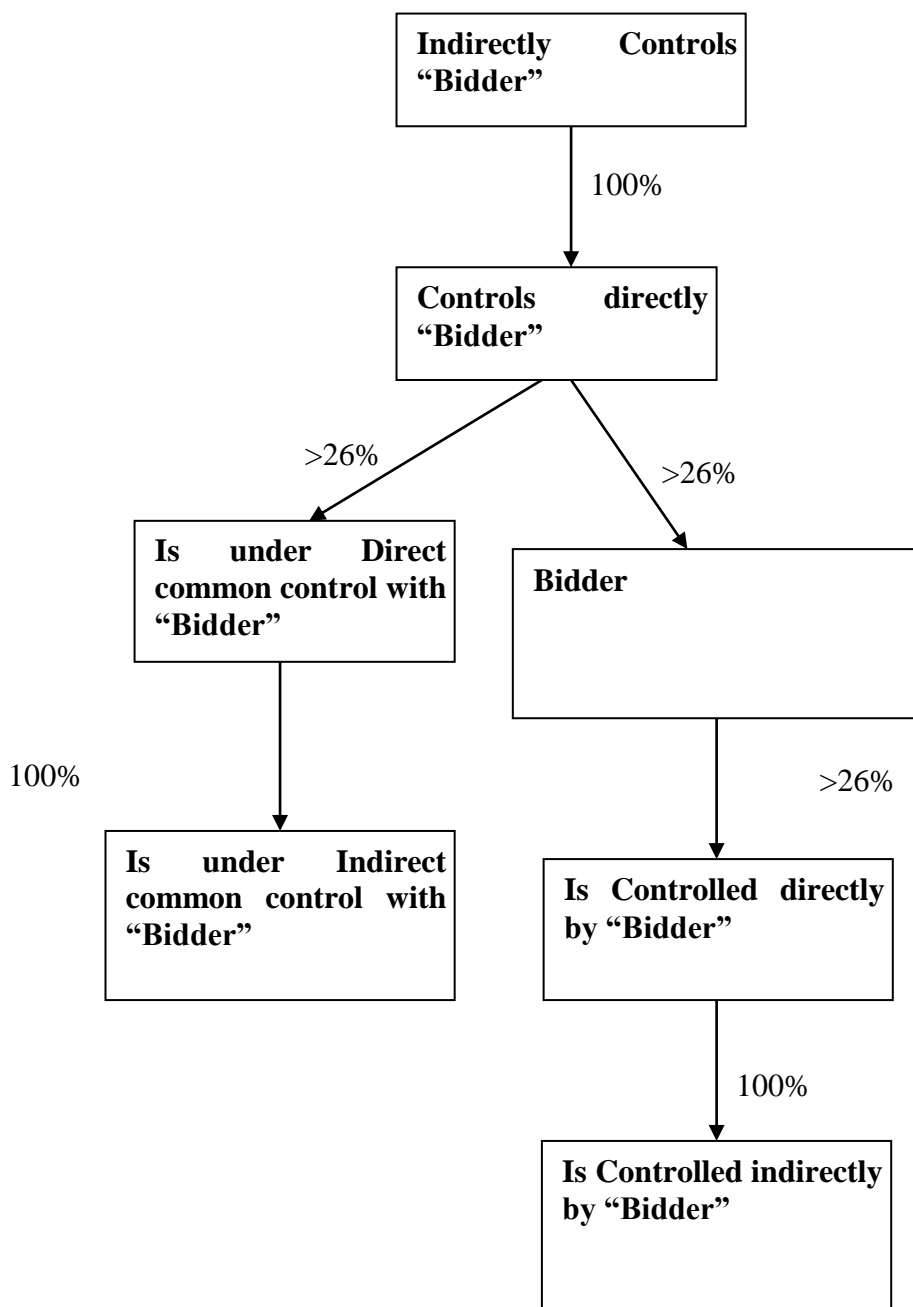

NOTE: Bidder to provide the illustration, as applicable in their case, duly certified by the Company Secretary and supported by documentary evidence in this regard.

ANNEXURE 13 - FORMAT FOR DISCLOSURE**[On the letter head of Bidding Company / Each Member in a Bidding Consortium]****Date:****DISCLOSURE**

We hereby declare that the following companies with which we/ have direct or indirect relationship are also separately participating in this Bid process as per following details

S. No.	Name of the Company	Relationship
1.		
2.		
3.		

In case there is no such company please fill in the column “name of the company” as Nil.

Further we confirm that we don't have any Conflict of Interest with any other company participating in this bid process.

Certified as True

.....

(Signature)

Name:

Signature & Name of authorized signatory of the Company and Stamp

The above disclosure should be signed and certified as true by the authorized signatory of the Bidding Company or of the Member, in case of a Consortium).

ANNEXURE 14 - FORMAT OF THE BID BOND**FORMAT OF THE UNCONDITIONAL AND IRREVOCABLE BANK
GUARANTEE FOR BID BOND**

(To be on non-judicial stamp paper of appropriate value as per Stamp Act relevant to place of execution.)

In consideration of the[Insert name of the Bidder] submitting the Bid inter alia for establishing the Inter-State transmission system for _____[Name of Project] on build, own, operate and transfer basis, in response to the RFP dated _____ issued by _____[Name of BPC], and the Bid Process Coordinator (hereinafter referred to as BPC) agreeing to consider such Bid of [Insert the name of the Bidder] as per the terms of the RFP, the [Insert name and address of the bank issuing the Bid Bond, and address of the Head Office] (hereinafter referred to as "Guarantor Bank") hereby agrees unequivocally, irrevocably and unconditionally to pay to _____[Name of BPC] or its authorized representative at _____[Address of BPC] forthwith on demand in writing from _____[Name of BPC] or any representative authorized by it in this behalf, any amount up to and not exceeding Rupees _____ Only (Rs _____ Crore), on behalf of M/s.....[Insert name of the Bidder].

This guarantee shall be valid and binding on the Guarantor Bank up to and including [Date to be inserted on the basis of Clause 2.11 of this RFP] and shall not be terminable by notice or any change in the constitution of the Guarantor Bank or by any other reasons whatsoever and our liability hereunder shall not be impaired or discharged by any extension of time or variations or alternations made, given, or agreed with or without our knowledge or consent, by or between concerned parties.

Our liability under this Guarantee is restricted to Rupees _____ Only (Rs _____ Crore). Our Guarantee shall remain in force until[Date to be inserted on the basis of Clause 2.11 of this RFP]. _____[Name of BPC] or its authorized representative shall be entitled to invoke this Guarantee until [Insert Date, which is three sixty five days (365) days after the date in the preceding sentence]. The Guarantor Bank hereby expressly agrees that it shall not require any proof in addition to the written demand from _____[Name of BPC] or its authorized representative, made in any format, raised at the above mentioned address of the Guarantor Bank, in order to make the said payment to _____[Name of BPC] or its authorized representative.

The Guarantor Bank shall make payment hereunder on first demand without restriction or conditions and notwithstanding any objection, disputes, or disparities raised by the Bidder or any other person. The Guarantor Bank shall not require _____[Name of BPC] or its authorized representative to justify the invocation of this BANK GUARANTEE, nor shall the Guarantor Bank have any recourse against _____[Name of BPC] or its authorized representative in respect of any payment made hereunder.

This BANK GUARANTEE shall be interpreted in accordance with the laws of India.

The Guarantor Bank represents that this BANK GUARANTEE has been established in such form and with such content that it is fully enforceable in accordance with its terms as against the Guarantor Bank in the manner provided herein.

This BANK GUARANTEE shall not be affected in any manner by reason of merger, amalgamation, restructuring or any other change in the constitution of the Guarantor Bank.

This BANK GUARANTEE shall be a primary obligation of the Guarantor Bank and accordingly _____[Name of BPC] or its authorized representative shall not be obliged before enforcing this BANK GUARANTEE to take any action in any court or arbitral proceedings against the Bidder, to make any claim against or any demand on the Bidder or to give any notice to the Bidder to enforce any security held by _____[Name of BPC] or its authorized representative or to exercise, levy or enforce any distress, diligence or other process against the Bidder.

Notwithstanding anything contained hereinabove, our liability under this Guarantee is restricted to Rupees _____ Only (Rs ____ Crore) and it shall remain in force until [Date to be inserted on the basis of Clause 2.11 of RFP], with an additional claim period of three hundred sixty five (365) days thereafter. We are liable to pay the guaranteed amount or any part thereof under this BANK GUARANTEE only if _____[Name of BPC] or its authorized representative serves upon us a written claim or demand.

In witness whereof the Bank, through its authorized officer, has set its hand and stamp on this..... day ofat.....

Witness:

1.....
Name and Address

Signature:
Name:

2.
Name and Address

Designation with Stamp:

Signature

Attorney as per power of attorney

No.....

For:
..... [Insert Name of the Bank]

Banker's Stamp and Full Address:

Dated this.....day of..... 20.....

Notes:

1. The Stamp Paper should be in the name of the Executing Bank.

~~ANNEXURE 14 A- FORMAT OF THE BID SECURITY DECLARATION [VALID
TILL RFP ISSUED ON OR BEFORE 31.12.2021]~~

ANNEXURE 15 - FORMAT FOR CONTRACT PERFORMANCE GUARANTEE

(To be on non-judicial stamp paper of appropriate value as per Stamp Act relevant to place of execution.

Foreign entities submitting Bids are required to follow the applicable law in their country)

In consideration of the [Insert name of the SPV or Selected Bidder on behalf of SPV or Lead Member in case of the Consortium, with address] agreeing to undertake the obligations under the Transmission Service Agreement dated and the other RFP Project Documents and the Nodal Agency and_[Name of BPC], agreeing to execute the RFP Project Documents with the Selected Bidder, regarding setting up the Project, the.....[Insert name and address of the bank issuing the guarantee and address of the head office] (hereinafter referred to as "Guarantor Bank") hereby agrees unequivocally, irrevocably and unconditionally to pay to the Nodal Agency at..... [Insert Place and Address of the Nodal Agency indicated in TSA] forthwith on demand in writing from the Nodal Agency or any Officer authorized by it in this behalf, any amount up to and not exceeding Rupees.....Crores (Rs.....) only [Insert the amount of the bank guarantee] on behalf of M/s..... [Insert name of the Selected Bidder / SPV].

This guarantee shall be valid and binding on the Guarantor Bank up to and includingand shall not be terminable by notice or any change in the constitution of the Bank or the term of the Transmission Service Agreement or by any other reasons whatsoever and our liability hereunder shall not be impaired or discharged by any extension of time or variations or alternations made, given, or agreed with or without our knowledge or consent, by or between parties to the respective agreement.

Our liability under this Guarantee is restricted to Rupees Crores (Rs.....) only. Our Guarantee shall remain in force until..... [Insert the date of validity of the Guarantee as per Clause 2.12.1 of the RFP]. The Nodal Agency shall be entitled to invoke this Guarantee up to three hundred sixty five (365) days of the last date of the validity of this Guarantee.

The Guarantor Bank hereby expressly agrees that it shall not require any proof in addition to the written demand from the Nodal Agency, made in any format, raised at the above mentioned address of the Guarantor Bank, in order to make the said payment to the Nodal Agency.

The Guarantor Bank shall make payment hereunder on first demand without restriction or conditions and notwithstanding any objection by _____[Name of SPV], [Insert name of the Selected Bidder], [Insert name of the TSP] and/or any other person. The Guarantor Bank shall not require the Nodal Agency to justify the invocation of this BANK GUARANTEE, nor shall the Guarantor Bank have any recourse against the Nodal Agency in respect of any payment made hereunder.

This BANK GUARANTEE shall be interpreted in accordance with the laws of India.

The Guarantor Bank represents that this BANK GUARANTEE has been established in such form and with such content that it is fully enforceable in accordance with its terms as against the Guarantor Bank in the manner provided herein.

This BANK GUARANTEE shall not be affected in any manner by reason of merger, amalgamation, restructuring, liquidation, winding up, dissolution or any other change in the constitution of the Guarantor Bank.

This BANK GUARANTEE shall be a primary obligation of the Guarantor Bank and accordingly the Nodal Agency shall not be obliged before enforcing this BANK GUARANTEE to take any action in any court or arbitral proceedings against _____[Name of SPV] or the Selected Bidder, to make any claim against or any demand on _____[Name of SPV] or the Selected Bidder, as the case may be, or to give any notice to _____[Name of SPV] or the Selected Bidder, as the case may be, or to enforce any security held by the Nodal Agency or to exercise, levy or enforce any distress, diligence or other process against_[Name of SPV] or the Selected Bidder, as the case may be.

The Guarantor Bank acknowledges that this BANK GUARANTEE is not personal to the Nodal Agency and may be assigned, in whole or in part, (whether absolutely or by way of security) by Nodal Agency to any entity to whom the Nodal Agency is entitled to assign its rights and obligations under the Transmission Service Agreement.

The Guarantor Bank hereby agrees and acknowledges that the Nodal Agency shall have a right to invoke this Bank Guarantee either in part or in full, as it may deem fit.

Notwithstanding anything contained hereinabove, our liability under this Guarantee is restricted to RupeesCrores (Rs) only and it shall remain in force until [Date to be inserted on the basis of Article 3.1.2 of TSA], with an additional claim period of three hundred sixty five (365) days thereafter. This BANK GUARANTEE shall be extended from time to time for such period, as may be desired by..... [Insert name of the Selected Bidder or Lead Member in case of the Consortium or SPV]. We are liable to pay the guaranteed amount or any part thereof under this Bank Guarantee only if the Nodal Agency serves upon us a written claim or demand.

In witness where of:

Signature.....

Name:

Power of attorney No.:

For:

..... [Insert Name of the Bank]

Banker's Seal and Full Address, including mailing address of the Head Office

Notes:

1. The Stamp Paper should be in the name of the Executing Bank.

ANNEXURE 16 – FORMAT OF CHECKLIST FOR TECHNICAL BID SUBMISSION REQUIREMENTS

[This format needs to be duly filled in, signed by the authorized signatory of the Bidder (Bidding Company / Lead Member in case of a Bidding Consortium) and submitted along with the Bidder's Technical Bid]

Technical Bid Submission Requirements	Response (Yes / No)
<ol style="list-style-type: none"> 1. Format for the Covering Letter on the letterhead of Bidding Company or Lead Member of the Consortium, as applicable; 2. Format for Letter of Consent from each Consortium Member, including Lead Member, on their respective letterheads; 3. Format for evidence of authorized signatory's authority ; 4. Board resolution from the Bidding Company / Lead Member of the Consortium in favour of the person executing the Power of Attorney as per Annexure 3; 5. Power of Attorney from each Consortium Member in favour of Lead Member to be provided by each of the other Members of the Consortium as per Annexure 4; 6. Board Resolution from each Member of the Consortium, other than the Lead Member, in favour of their respective authorized representatives for executing the POA, Consortium Agreement and signing of the requisite formats; 7. Format for Bidder's composition and ownership structure, along with status of equity holding (owning ten percent or more of the total paid up equity) not earlier than thirty (30) days prior to the Bid Deadline as per Annexure 5; 8. Consortium Agreement duly signed as per Annexure 6, along with Appendix-1, indicating the responsibilities and obligations of each Member of the Consortium; 9. Format for Qualification Requirement: <ol style="list-style-type: none"> a. Calculation sheets, detailing computation of Networth considered for meeting Qualifying Requirements, duly signed and stamped by the Statutory Auditor of the Bidding Company / each Member in case of a Bidding Consortium / FEE in cases where credentials of FEE is taken; b. Calculation sheets, detailing computation of capital expenditure of projects and revenue received in construction projects considered for meeting Qualification Requirements, duly signed and stamped by the Statutory Auditor of the Bidding Company / Lead Member in case of Bidding Consortium / TEE in cases where credentials of TEE is taken; 	

Technical Bid Submission Requirements	Response (Yes / No)
<p>c. Last financial year unconsolidated / consolidated audited annual accounts / statements, as the case may be, of the Financially Evaluated Entity / Technical Evaluated Entity</p> <p>d. Unconsolidated audited annual accounts of both the TEE and the Bidding Company/Lead member, as applicable, from the financial years in which financial closure was achieved till the financial year in which the said project was completed / commissioned.</p> <p>10. Copy of the Memorandum and Articles of Association and certificate of incorporation or other organizational document (as applicable), including their amendments, certified by the Company Secretary of Bidding Company or each Member in case of a Consortium including Lead Member.</p> <p>11. Attachment of Annexure 7(D), detailing projects completed / commissioned and for which commercial operation has commenced including Executive Summary for each project.</p> <p>12. For each project listed in the attachment above, certified true copy of the certificates of final acceptance and / or certificates of good operating performance duly issued by owners or clients for the project, duly signed by authorized signatory in support of technical capability as defined in Clause 2.1.2 of RFP.</p> <p>13. Authority letter in favour of BPC from the Bidder/every Member of the Consortium authorizing the BPC to seek reference from their respective bankers & others.</p> <p>14. Authorization from Parent / Affiliate of Bidding Company / Member of Bidding Consortium whose technical / financial capability has been used by the Bidding Company / Member of Bidding Consortium.</p> <p>15. Initialing of all pages of Technical Bid by the Authorized Signatory in whose favour the POA (Annexure 3) has been executed.</p> <p>16. Format for Illustration of Affiliates at the most seven (7) days prior to the Bid Deadline, duly certified by Company Secretary and supported by documentary evidence.</p> <p>17. Certified copy of the Register of Members / Demat Account Statement, Share Certificate, Annual Return filed with ROC etc. submitted as documentary evidence along with Annexure 12.</p> <p>18. Format for Disclosure by Bidding Company / each Member of the Consortium.</p> <p>19. Format for Affidavit by the Bidding Company / each Member of the Consortium</p>	

Technical Bid Submission Requirements	Response (Yes / No)
20. Format for Authorization submitted in Non-Judicial stamp paper duly notarized.	
21. Bidders Undertaking and details of Equity Investment	
22. Proof of Payment of RFP Fees	
23. Bid Bond/ Bid Security Declaration (As applicable)	
24. Board Resolution as per Annexure 11 (If required)	

[**Note:** The checklist is not exhaustive. Bidders are required to submit all the information/documents as per requirement of RFP]

For and on behalf of Bidder

M/s.

.....
(Signature of authorized signatory)

ANNEXURE 17 – LIST OF BANKS

All Scheduled Commercial Banks as per Second Schedule of RBI Act-1934 and any amendments thereof.

ANNEXURE 18 - GRID MAP OF THE PROJECT

Western Region Network Expansion scheme in Kallam area of Maharashtra

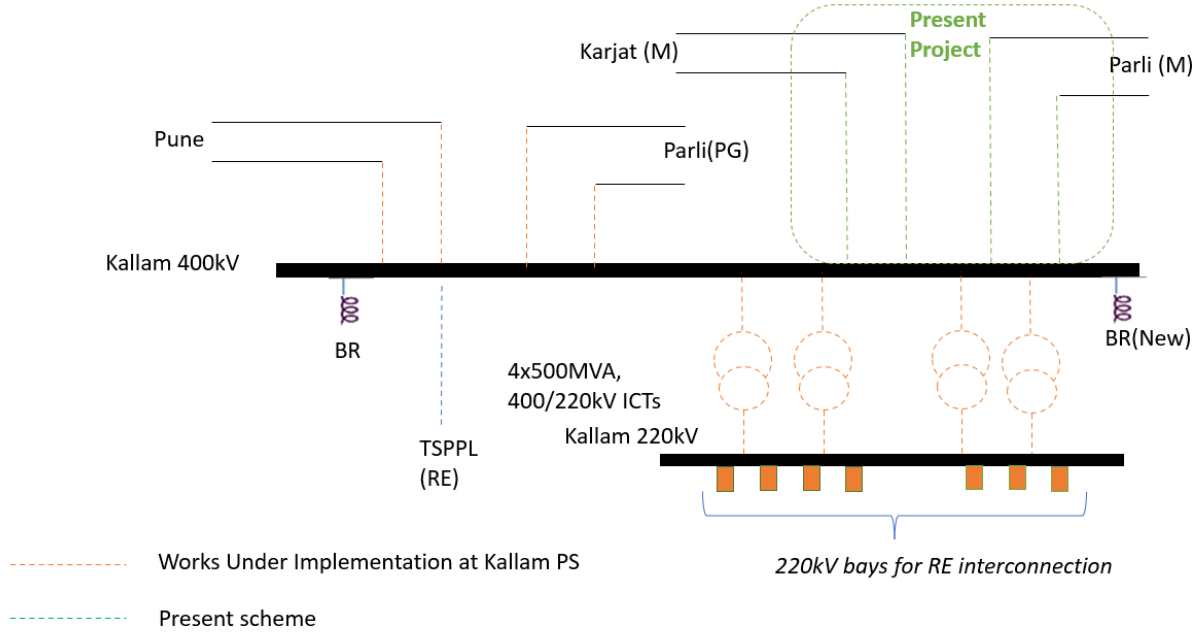

**ANNEXURE 19 - FORMAT FOR CLARIFICATIONS / AMENDMENTS ON THE RFP /
RFP PROJECT DOCUMENTS**

S. No.	Name of the Document	Clause No. and Existing provision	Clarification required	Suggested text for the amendment	Rationale for the Clarification or Amendment

Signature

Name.....

For

Bidder's Rubber Stamp and Full Address.

(Note: This format shall be used for submission of requests for clarifications/ amendments on the draft RFP Project Documents as per the provisions of Clause 2.3.1)

ANNEXURE 20 - LIST FOR RFP PROJECT DOCUMENTS

ENCLOSURE 1: TRANSMISSION SERVICE AGREEMENT (Provided separately)

ENCLOSURE 2: SHARE PURCHASE AGREEMENT (Provided Separately)

ANNEXURE 21 - FORMAT FOR FINANCIAL BID**[To be uploaded online]****Quoted Transmission Charges****Notes**

1. The Bidders are required to ensure compliance with the provisions of Clause 2.5.3 of this RFP.
2. Quotes to be in Rupees Millions and shall be up to two (2) decimal points.
3. The contents of this format shall be clearly typed.
4. The Financial Bid shall be digitally signed by the authorized signatory in whose name power of attorney as per Clause 2.5.2 is issued.
5. Ensure only one value for annual Transmission Charges is quoted. The same charge shall be payable every year to TSP for the term of TSA.

ANNEXURE 22 – FORMAT FOR AFFIDAVIT

[On non-judicial stamp paper. Foreign companies submitting bids are required to follow the applicable law in their country]

AFFIDAVIT

We [including any of our Affiliate and Consortium Member & any of its Affiliate], hereby declare that as on Bid Deadline:

- a. the Bidder & any of its Affiliate including any Consortium Member & any of its Affiliate, their directors or key personnel have not been barred or included in the blacklist by any government agency or authority in India, the government of the jurisdiction of the Bidder or Members where they are incorporated or the jurisdiction of their principal place of business, any international financial institution such as the World Bank Group, Asian Development Bank, African Development Bank, Inter-American Development Bank, Asian Infrastructure Investment Bank etc. or the United Nations or any of its agencies; or
- b. the Bidder & any of its Affiliate including any Consortium Member & any of its Affiliate or their directors have not been convicted of any offence in India or abroad.

We further declare that following investigations are pending / no investigation is pending [strike off whichever is not applicable] against us [including any of our Consortium Member or Affiliate or Parent or Ultimate Parent or Affiliate] or CEO or any of our directors/ manager/key managerial personnel of the Applicant /Consortium Member or their Affiliates.

We further undertake to inform the BPC of any such matter as mentioned above on its occurrence after the date of this affidavit till the Effective Date.

We undertake that, in case, any information provided in relation to this affidavit is found incorrect at any time hereafter, our BID / Letter of Intent / contract (if entered) would stand rejected / recalled / terminated, as the case may be.

.....
Signature and Name of the authorized signatory of the Company Bidding Company / Lead Member of the Bidding Consortium

.....
(Signature of Notary Public)

Place:

Date:

Note: In case any investigation is pending against the Applicant, including any Consortium Member or Affiliate, or CEO or any of the directors/ manager/key managerial personnel of the Applicant /Consortium /Member or their Affiliates, full details of such investigation including

the name of the investigating agency, the charge/offence for which the investigation has been launched, name and designation of persons against whom the investigation has been launched and other relevant information should be disclosed under this affidavit.

ANNEXURE A**Technical Details with respect to electronic bidding****Registration Methodology**

In order to submit online bids in the e-bidding process for selection of Transmission Service Provider, interested Bidders are required to register themselves with the e-procurement website of MSTC Limited namely www.mstcecommerce.com/eprochome/tsp/index.jsp. To register with the website, the Bidder is required to fill up the online form available under the link Register as Vendor in the above website and fill up the same and click on Submit.

During this process, the bidder shall create his user id and password and keep note of the same. The bidder shall ensure that the secrecy of his user id and password is maintained at all time and he/she shall alone be responsible for any misuse of the user id and password.

The bidder may check the details entered by it before final submission. On successful submission of the online registration Form, the bidder shall receive a confirmation mail in the registered email address advising the bidder to submit the following documents.

- i. Self attested Income Tax PAN Card. In case of a registered Company or Firm, the Firm's PAN card and in case of a proprietorship firm, proprietor's personal PAN card is required. In case of partnership firm, PAN of the firm and that of the authorized partner are to be submitted.
- ii. Copy of the confirmation email Letter received from MSTC after successful completion of on-line registration..
- iii. A non refundable registration fee of Rs 10,000/- plus applicable GST to be paid online.

Please provide details of payment made like UTR No, remitting bank name, date of payment and amount in the covering letter.

The bidder shall have to submit all the above documents to MSTC Limited for verification and activation of their login ids. The bidders should send scanned copies of the above documents to the designated email id only which is given below.

tsp@mstcindia.co.in

It may be noted that bidders need not visit any of the offices of MSTC Limited for submission of the documents.

Contact persons of MSTC Limited:

Mr. Setu Dutt Sharma, 7878055855

Once the complete set of documents and requisite registration fee are received from a bidder, MSTC shall activate the bidder's login after verification / scrutiny of the documents. MSTC Limited reserves the right to call for additional documents from the bidder if needed and the bidder shall be obliged to submit the same.

On completion of the above stated registration process, a bidder shall be able to login to MSTC's website.

ANNEXURE B

Draft Pre-Award Integrity Pact

GENERAL

This pre-bid contract Agreement (herein after called the Integrity Pact) is made on day of the month of 20....., between, on one hand, [Insert name of BPC] through Shri [Insert Name & designation of representative of BPC] (hereinafter called the "Bid Process Coordinator/ BPC", which expression shall mean and include, unless the context otherwise requires, his successors in the office and assigns) of the First Part and M/s represented by Shri [Insert Name & Designation of Authorized Signatory of the Bidder/ Lead Member of Consortium] (hereinafter called the "Bidder" which expression shall mean and include, unless the context otherwise requires, his successors and permitted assigns) of the Second Part.

WHEREAS the BPC is conducting the bidding process for selection of bidder as Transmission Service Provider (TSP) for “Western Region Network Expansion scheme in Kallam area of Maharashtra” who will be responsible to set up the transmission project on build, own, operate and transfer (BOOT) basis and to provide Transmission Service.

WHEREAS the Bidder is a Private Company/Public Company/Government Undertaking/ Partnership, constituted in accordance with the relevant law in the matter and the BPC is a Public Sector Undertaking (PSU) performing its function on behalf of the Ministry of Power, Government of India.

NOW, THEREFORE,

To avoid all forms of corruption by following a system that is fair, transparent and free from any influence/prejudiced dealings during the complete bidding process with a view to:-

Enabling the BPC to select the bidder as TSP in conformity with the defined procedures by avoiding the high cost and the distortionary impact of corruption on public procurement, and

Enabling Bidder to abstain from bribing or indulging in any corrupt practice in order to emerge as selected bidder by providing assurance to them that their competitors will also abstain from bribing and other practices and the BPC will commit to prevent corruption, in any form, by its officials by following transparent procedures.

The parties hereto hereby agree to enter into this Integrity Pact and agree as follows:

Commitments of BPC

1.1 The BPC undertakes that no official of the BPC, connected directly or indirectly with

the bidding process, will demand, take a promise for or accept, directly or through intermediaries, any bribe, consideration, gift, reward, favour or any material or immaterial benefit or any other advantage from the BIDDER, either for themselves or for any person, organization or third party related to the bidding process in exchange for an advantage in the bidding process, bid evaluation, contracting or implementation process related to the contract.

- 12 The BPC will, during the bidding stage, treat all bidders alike, and will provide to all bidders the same information and will not provide any such information to any particular bidder which could afford an advantage to that particular bidder in comparison to the other bidders.
- 13 All the officials of the BPC will report the appropriate Government office any attempted or completed breaches of the above commitments as well as any substantial suspicion of such a breach.
- 2 In case of any such preceding misconduct on the part of such official(s) is reported by the Bidder to the BPC with the full and verifiable facts and the same is *prima facie* found to be correct by the BPC, necessary disciplinary proceedings, or any other action as deemed fit, including criminal proceedings may be initiated by the BPC and such a person shall be debarred from further dealings related to the bidding process. In such a case while an enquiry is being conducted by the BPC the proceedings under the bidding process would not be stalled.

Commitments of Bidder

3. The Bidder commits itself to take all measures necessary to prevent corrupt practices, unfair means and illegal activities during any stage of its bid or during any pre award stage in order to emerge as Selected Bidder or in furtherance to secure it and in particular commits itself to the following:-
 - 3.1 The Bidder will not offer, directly or through intermediaries, any bribe, gift, consideration, reward, favour, any material or immaterial benefit or other advantage, commission, fees, brokerage or inducement to any official of the BPC, connected directly or indirectly with the bidding process, or to any person, organization or third party related to the bidding process in exchange for any advantage in the bidding, evaluation, contracting and implementation of the bidding process.
 - 3.2 The Bidder further undertakes that it has not given, offered or promised to give, directly or indirectly any bribe, gift, consideration, reward, favour, any material or immaterial benefit or other advantage, commission, fees, brokerage or inducement to any official of the BPC or otherwise in bidding process or for bearing to do or having done any act in relation to bidding process or any other contract with the Government for showing or forbearing to show favour or disfavour to any person in relation to the

- bidding process or any other contract with the Government.
- 33 The Bidder shall disclose the name and address of agents and representatives and Indian Bidder shall disclose their foreign principals or associates.
- 34 The Bidder shall disclose the payments to be made by them to agents/brokers or any other intermediary, in connection with this bid .
- 35 The Bidder further confirms and declares to the BPC that the Bidder has not engaged any individual or firm or company whether Indian or foreign to intercede, facilitate or in any way to recommend to the BPC or any of its functionaries, whether officially or unofficially for selection of Bidder as TSP, nor has any amount been paid, promised or intended to be paid to any such individual, firm or company in respect of any such intercession, facilitation or recommendation.
- 36 The Bidder, either while presenting the bid or during pre-award negotiations or before signing the Share Purchase Agreement, shall disclose any payments he has made, is committed to or intends to make to officials of the BPC or their family members, agents, brokers or any other intermediaries in connection with the bidding process and the details of services agreed upon for such payments.
- 37 The Bidder will not collude with other parties interested in the bidding process to impair the transparency, fairness and progress of the bidding process.
- 38 The Bidder will not accept any advantage in exchange for any corrupt practice, unfair means and illegal activities.
- 39 The Bidder shall not use improperly, for purpose of competition or personal gain, or pass on to others, any information provided by the BPC as part of the business relationship, regarding plans, technical proposal and business details, including information contained in any electronic data carrier. The Bidder also undertakes to exercise due and adequate care lest any such information is divulged.
- 3.10 The Bidder commits to refrain from giving any complaint directly or through any other manner without supporting it with full and verifiable facts.
- 3.11 The Bidder shall not instigate or cause to instigate any third person to commit any of the actions mentioned above.
- 3.12 The Bidder shall not lend to or borrow any money from or enter into any monetary dealings or transactions, directly or indirectly, with any employee of the BPC.

4 Previous Transgression

4.1 The Bidder declares that no previous transgression occurred in the last three years immediately before signing of this Integrity Pact, with any other company in any country in respect of any corrupt practices envisaged hereunder or with any Public Sector Enterprise in India or any Government Department in India that could justify Bidder's exclusion from the bidding process.

4.2 The Bidder agrees that if it makes incorrect statement on this subject, Bidder can be disqualified from the tender process or the contract, if already awarded, can be terminated for such reason.

5. Bid Bond (Security Deposit)

5.1 Along with the technical bid, the Bidder shall submit Bid Bond for an amount of Rs. (as per the amount specified in Request for Proposal (RFP) Document) issued by [Insert Name of the Banks from the list provided in RFP Document] as Earnest Money/Security Deposit, with the BPC.

5.2 The Earnest Money/Security Deposit shall be valid & retained by the BPC for such period as specified in the RFP Document.

5.3 No interest shall be payable by the BPC to the Bidder on Earnest Money/Security Deposit for the period of its currency.

6. Sanctions for Violations

6.1 Any breach of the aforesaid provisions by the Bidder or any one employed by it or acting on its behalf (whether with or without the knowledge of the Bidder) shall entitle the BPC to take all or anyone of the following actions, wherever required:-

- (i) To immediately call off the pre-award negotiations without assigning any reason or giving any compensation to the Bidder. However, the proceedings with the other Bidder (s) would continue.
- (ii) The Bid Bond (in pre-award stage) shall stand forfeited either fully or partially, as decided by the BPC and the BPC shall not be required to assign any reason therefore.
- (iii) To immediately cancel the award, if already awarded, without giving any compensation to the Bidder.
- (iv) To cancel all or any other contracts with the Bidder. The Bidder shall be liable to pay compensation for any loss or damage to the BPC resulting from such cancellation/rescission.

- (v) To debar the Bidder from participation in any tender or RFP issued by any BPC for an indefinite period.
- (vi) To recover all sums paid in violation of this Pact by Bidder to any middleman or agent or broker with a view to securing the award.
- 62 The BPC will be entitled to take all or any of the actions mentioned at para 6.1 (i) to (vi) of this Pact also on the Commission by the Bidder or anyone employed by it or acting on its behalf (whether with or without the knowledge of the Bidder), of an offence as defined in Chapter IX of the Indian Penal code, 1860 or Prevention of Corruption Act, 1988 or any other statute enacted for prevention of corruption.
- 63 The decision of the BPC to the effect that a breach of the provisions of this Pact has been committed by the Bidder shall be final and conclusive on the Bidder. However, the Bidder can approach the Independent Monitor(s) appointed for the purposes of this Pact.
- 7. Independent Monitors**
- 7.1 The BPC has appointed Independent Monitors (hereinafter referred to as Monitors) for this Pact in consultation with the Central Vigilance Commission (Names and Addresses of the Monitors to be given).
- 7.2 The task of the Monitors shall be to review independently and objectively, whether and to what extent the parties comply with the obligations under this Pact.
- 7.3 The Monitors shall not be subject to instructions by the representatives of the parties and perform their functions neutrally and independently.
- 7.4 Both the parties accept that the Monitors have the right to access all the documents relating to the project/procurement, including minutes of meetings.
- 7.5 As soon as the Monitor notices, or has reason to believe, a violation of this Pact, he will so inform the Authority designated by the BPC.
- 7.6 The Bidder accepts that the Monitors has the right to access without restriction to all Project documentation of the BPC including that provided by the Bidder. The Monitor shall be under contractual obligation to treat the information and documents of the Bidder /Subcontractors(s) with confidentially. [As all the bid documents are with BPC only]
- 7.7 The BPC will provide to the Monitors sufficient information about all meetings among the parties related to the Project provided such meetings could have an impact on the contractual relations between the parties. The parties will offer to the monitor the

option to participate in such meetings.

- 78 The Monitor will submit a written report to the designated Authority of the BPC/Secretary in the Department within 8 to 10 weeks from the date of reference or intimation to him by the BPC / Bidder and, should the occasion arise, submit proposals for correcting problematic situations.

8 Facilitation of Investigation

In case of any allegation of violation of any provisions of this Pact or payment of commission, the BPC or its agencies shall be entitled to examine all the documents including the Books of Accounts of the Bidder and the Bidder shall provide necessary information and documents in English and shall extend all possible help for the purpose of such examination.

9 Law and Place of Jurisdiction

This Pact is subject to Indian Law. The place of performance and jurisdiction is the seat of the BPC.

10 Other Legal Actions

The actions stipulated in this Integrity Pact are without prejudice to any other legal action that may follow in accordance with the provisions of the any extent law in force relating to any civil or criminal proceedings.

11 Validity

- 11.1 The validity of this Integrity Pact shall be from date of its signing and upto 6 months from the date of transfer of project specific SPV i.e., signing of Share Purchase Agreement with BPC. In case Bidder is unsuccessful, this Integrity Pact shall expire after 15 days from the date of transfer of project specific SPV to successful bidder.
- 11.2 Should one or several provisions of this Pact turn out to be invalid, the remainder of this Pact shall remains valid. In this case, the parties will strive to come to an agreement to their original intentions.
- 12 The Parties hereby sign this Integrity Pact at _____ on _____

<p>Bid Process Coordinator (BPC)</p> <p>Name of the Officer Designation Name of the BPC with address</p> <p>Witness:</p> <p>1. _____</p> <p>2. _____</p>	<p>BIDDER</p> <p>Name of Whole time Director/Authorized Signatory Name of the Bidder with address</p> <p>Witness:</p> <p>1. _____</p> <p>2. _____</p>
---	--

ANNEXURE C

Technical Specifications of Transmission System

SPECIFIC TECHNICAL REQUIREMENTS FOR TRANSMISSION LINE

The design, routing and construction of transmission lines shall be in accordance with Chapter V, Part A of CEA (Technical Standards for Construction of Electrical Plants and Electric Lines) Regulations 2022, as amended from time to time. Other CEA Regulations and MoP guidelines, as applicable, shall also be followed.

- A.1.0 Selection of tower type shall be made as per CEA Regulations, however in case lattice type towers are used, the following shall also be applicable:
- A.2.0 Steel section of grade E 250 and/or grade E 350 as per IS 2062, only are permitted for use in towers, extensions, gantry structures and stub setting templates. For towers in snowbound areas, steel sections shall conform to Grade-C of IS-2062.
- A.3.0 Towers shall be designed as per IS-802:2015, however the drag coefficient of the tower shall be as follows: -

Solidity Ratio	Drag Coefficient
Upto 0.05	3.6
0.1	3.4
0.2	2.9
0.3	2.5
0.4	2.2
0.5 and above	2.0

- A.4.0 Transmission Service Provider (TSP) shall adopt any additional loading/design criteria for ensuring reliability of the line, if so desired and /or deemed necessary.
- A.5.0 Transmission line shall be designed considering wind zones as specified in wind map given in National Building Code 2016, Vol.1. The developer shall also make his own assessment of local wind conditions and frequent occurrences of high intensity winds (HIW) due to thunderstorms, dust-storms, downburst etc. along the line route and wherever required, higher wind zone than that given in wind map shall be considered for tower design for ensuring reliability of line. Further, for transmission line sections passing within a distance of 50 km from the boundary of two wind zones, higher of the two wind zones shall be considered for design of towers located in such sections.
- A.6.0 Selection of reliability level for design of tower shall be as per CEA Regulation (Technical Standards for Construction of Electrical Plants and Electric Lines) Regulations 2022, as amended from time to time.
- A.7.0 A) For power line crossing of 400 kV or above voltage level, large angle & dead end towers (i.e. D/DD/QD) shall be used on either side of power line crossing.
- B) For power line crossing of 132 kV and 220 kV voltage level, angle towers (B/C/D/DB/DC/DD/QB/QC/QD) shall be used on either side of power line crossing

depending upon the merit of the prevailing site condition and line deviation requirement.

C) For power line crossing of 66 kV and below voltage level, suspension/tension towers shall be provided on either side of power line crossing depending upon the merit of the prevailing site condition and line deviation requirement.

D) For crossing of railway tracks, national highways and state highways, the rules/regulations of appropriate authorities shall be followed.

A.8.0 The relevant conductor configuration for 400kV shall be as follows: -

Transmission line	ACSR Conductor specified	Equivalent AAAC conductor based on 53% conductivity of Al Alloy	Equivalent minimum size of AL59 conductor based on 59% conductivity of AL Alloy*	Sub-conductor Spacing
400kV D/C (Twin Moose) transmission lines	Moose: Stranding 54/3.53mm-Al + 7/3.53 mm- Steel, 31.77 mm diameter 528.5 sq. mm, Aluminium area, Maximum DC Resistance at 20°C (Ω/km): 0.05552 Minimum UTS: 161.20 kN	Stranding details: 61/3.55mm 31.95mm diameter; 604 sq. mm Aluminium alloy area Maximum DC Resistance at 20°C (Ω/km): 0.05506 Minimum UTS: 159.80 kN	Stranding details: 61/3.31mm 29.79 mm diameter; 525 sq. mm Aluminium alloy area Maximum DC Resistance at 20°C (Ω/km): 0.0566 Minimum UTS: 124.70 kN	450 mm

Note:

1. *To Select any size above the minimum, the sizes mentioned in the Indian standard IS-398(part-6) shall be followed.
2. The transmission lines shall have to be designed for a maximum operating conductor temperature of 85 deg C.

A.9.0 The required phase to phase spacing and horizontal spacing for 400kV line shall be governed by the tower design as well as minimum live metal clearances for 400kV voltage level under different insulator swing angles. However, the phase to phase spacing for 400kV line shall not be less than 8 m.

A.10.0 Electrical clearances including minimum live metal clearance, ground clearance and minimum mid span separation between earth wire and conductor as given below shall be considered:

Minimum live metal clearances for 400 kV line:

(i) Under stationary conditions

From tower body: 3.05 m

(ii) Under swing conditions

Wind pressure Condition	Minimum electrical clearance
a) Swing angle (22°)	3.05 m
b) Swing angle (44°)	1.86 m

(iii) Minimum ground clearance: 8.84 m

(iv) Minimum mid span separation between earth-wire and conductor: 9.0 m

A.11.0 Shielding angle shall not exceed 20 deg for 400kV D/C Line transmission line.

A.12.0 The Fault current for design of line shall be 63kA for 1 sec for 400kV.

A.13.0 In case of 400kV & above voltage class lines, at least one out of two earth wires shall be OPGW and second earth wire, if not OPGW, shall be either of galvanized standard steel (GSS) or Aluminium Alloy Conductor Steel Reinforced (AACSR) conductor type. or any other suitable conductor type depending upon span length and other technical consideration.

A.14.0 Each tower shall be earthed such that tower footing impedance does not exceed 10 ohms. Pipe type or Counterpoise type earthing shall be provided in accordance with relevant IS. Additional earthing shall be provided on every 7 to 8 kms distance for direct earthing of both shield wires. If site condition demands, multiple earthing or use of earthing enhancement compound shall be used.

A.15.0 Pile type foundation shall be used for towers located in river or creek bed or on bank of river having scourable strata or in areas where river flow or change in river course is anticipated, based on detailed soil investigation and previous years' maximum flood discharge of the river, maximum velocity of water, highest flood level, scour depth & anticipated change in course of river based on river morphology data of at least past 20 years to ensure availability and reliability of the transmission line.

A.16.0 Transmission line route shall be finalized, in consultation with appropriate authorities so as to avoid the habitant zones of endangered species and other protected species. Bird diverters, wherever required, shall be provided on the line.

A.17.0 Wherever, transmission lines are passing through cyclone prone areas i.e. areas upto 60 km from coast following shall also be applicable:

- a) Terrain category-I, with terrain roughness factor (K2) of 1.08 shall be considered for tower design for exposed open terrain with few or no obstruction which also includes

open sea coasts, open stretch of water, desert and flat treeless plains

- b) Importance factor for cyclonic region (K4) of 1.3 shall be considered for tower design.
- c) The number of consecutive spans between the section points/ angle point shall not exceed 10 spans or 3km instead of conventional practice of 15 spans or 5km, in order to reduce the failure of such towers in coastal areas due to cascading effect. The section shall be terminated with tension tower/ angle tower and angle of deviation should be based on the site requirement.

A.18.0 Wherever, transmission lines are passing through cyclone prone areas (i.e. areas upto 60 km from coast)/ creek regions/ aggressive soil areas following shall also be applicable:

- a) The fabricated tower parts and stubs shall have a minimum overall zinc coating of 900 g/m² of surface area except for plates and sections below 5 mm which shall have a minimum overall zinc coating of 610 g/m² of surface area. The average zinc coating for all sections and plates 5mm and above shall be maintained as 127 microns and that for plates and sections below 5mm shall be maintained as 87 microns.
- b) Ready mix concrete of M30 Grade shall be used to avoid use of locally available saline water. However, design mix concrete of M30 Grade conforming to IS 456 with potable water can be used at locations where transportation of ready-mix concrete is not feasible. Minimum cement content in any case shall not be less than 330 kg/m³.
- c) The surface of the reinforced steel shall be treated with epoxy-based coating to enhance corrosion performance of foundation. Use of epoxy coated reinforcement in foundation shall be as per IS 13620. In addition, two (2) coats of bituminous painting of minimum 1.6 kg/m² per coat shall be applied on all exposed faces of foundation (i.e. pedestal & base slab).
- d) Double coat 20 mm thick cement plaster shall be provided on all exposed concrete surface as well up to 300 mm below ground level to give protection to concrete surface from environmental and saline effect.
- e) Before coping of chimney top portion, three coats of anti-corrosive paint of minimum 30-35 microns dry film thickness each shall be applied on the stub in the 50mm coping portion as well as up to 350 mm above CL portion.

A.19.0 The raised chimney foundation is to be provided in areas prone to flooding/water stagnation like paddy field /agricultural field & undulated areas to avoid direct contact of water with steel part of tower. The top of the chimney of foundation should be at least above HFL (High Flood Level) or the historical water stagnation/ logging level (based on locally available data) or above High Tide Level or 500 mm above Natural Ground level (whichever is higher).

A.20.0 Routing of transmission line through protected areas of India shall be avoided to the extent possible. In case, it is not possible to avoid protected areas, the towers of the transmission line upto 400 kV level which are installed in protected areas shall be designed for Multi-circuit (4 circuits) configuration of same voltage level considering reliability level of at least two (2). The top two circuits of these multi-circuit towers

shall be used for stringing of the transmission line under present scope and the bottom two circuits shall be made available for stringing of any future transmission line of any transmission service providers/ State transmission utilities/Central transmission utilities passing through the same protected area. Further, the configuration and coordinates of such transmission towers shall be submitted to CEA, CTU & BPC by the TSP.

- A.21.0 The TSP shall abide by the Guidelines of CEA w.r.t. shifting of transmission lines for NHAI projects and other projects.
- A.22.0 Safety precautions in regards to gas/oil pipe lines in vicinity of Transmission lines shall be taken in coordination with gas/ petroleum authorities.

SPECIFIC TECHNICAL REQUIREMENTS FOR SUBSTATION

The proposed extension of Kallam substation shall be conventional Air Insulated Switchgear (AIS) type generally conforming to the requirements of CEA (Technical Standards for Construction of Electrical Plants and Electric Lines) Regulations 2022, as amended from time to time. Other CEA Regulations and MoP guidelines, as applicable, shall also be followed.

B.1.0 Salient features of Substation Equipment and Facilities

The design and specification of substation equipment are to be governed by the following factors:

B.1.1 Insulation Coordination

The system design parameters for substations/switchyards shall be as given below:

Sl. No.	Description of parameters	400kV Kallam (AIS) S/s
		400 kV System
1.	System operating voltage	400kV
2.	Maximum voltage of the system (rms)	420kV
3.	Rated frequency	50Hz
4.	No. of phase	3
5.	Rated Insulation levels	
i)	Lighting Impulse withstand voltage for (1.2/50 micro sec.) - for Equipment other than Transformer and Reactor - for Insulator String	1425kVp 1550kVp
ii)	Switching impulse withstand voltage (250/2500 micro sec.) dry and wet	1050kVp
iii)	One minute power frequency dry withstand voltage (rms)	630kV
6.	Corona extinction voltage	320kV
7.	Max. radio interference voltage for frequency between 0.5 MHz and 2 MHz	1000 micro-volts at 266kV rms
8.	Minimum creepage distance for insulator string/ longrod insulators/ outdoor bushings	13020 mm (31mm/kV)
9.	Minimum creepage distance for switchyard equipment	10500 mm (25mm/kV)
10.	Max. fault current	63kA
11.	Duration of fault	1 Sec

B.1.2 Switching Scheme

The switching schemes, as mentioned below, shall be adopted at various voltage levels of substation/switchyard:

Substation	400kV side
400kV Kallam Extn. (AIS)	One & half breaker

Notes: -

- i) *For one and half breaker switching scheme, any double circuit line consisting of two numbers of feeders and originating from the same transmission or generating switchyard shall not be terminated in one diameter.*
- ii) *A diameter in one and half breaker scheme is a set of 3 circuit breakers with associated isolators, earth switches, current transformers etc. for controlling of 2 numbers of feeders.*
- iii) *Connection arrangement of Switchable Line reactors shall be such that it can be used as Line reactor as well as Bus reactor with suitable NGR bypass arrangement.*
- iv) *TSP shall plan distribution of line and transformer feeders to bus bar in such a way that all power can be evacuated successfully without crossing thermal limit at any point of bus-bar.*
- v) *400kV line bays shall be constructed such that provision is kept for future switchable line reactors.*

B.2.0 Substation Equipment and facilities (Voltage level as applicable):

The switchgear shall be designed and specified to withstand operating conditions and duty requirements. All equipment shall be designed considering the following capacity.

Sl. No	Description of bay	400kV Kallam (AIS) Extn.
		400kV
1.	Bus Bar	As per existing
2.	Line bay	3150A

B.2.1 Shunt Reactors**B.2.1.1 420kV, 3-Phase, Shunt Reactor**

63MVAR, 420 KV, 3-Phase Reactor shall conform to CEA's "Standard Specifications and Technical Parameters for Transformers and Reactors (66 kV and above)" as amended up to date available on CEA website.

The Ohmic value of NGR for Line Reactors shall be as follows:

Sl. No.	Line Name	NGR value
1.	63 MVA _r , 420 kV switchable line reactor on each ckt of Karjat – Kallam 400kV D/c line at Kallam PS end.	400 Ohms

B.2.2 400kV AIS Substation equipment (as applicable)

B.2.2.1 Circuit Breakers (AIS)

The circuit breakers and accessories shall conform to IEC: 62271-100, IEC: 62271-1 and shall be of SF6 Type. The circuit breakers shall be of class C2-M2 (as per IEC) with regard to restrike probability during capacitive current breaking and mechanical endurance. Each breaker would have two sets of trip circuits which would be connected to separate DC supplies for greater reliability. The rated break time shall not exceed 40ms for 400kV circuit breakers. The Circuit breakers controlling 400kV lines of more than 200km length shall be provided either with pre-insertion closing resistor of 400 ohms with 8ms insertion time or with Controlled Switching Device. 400kV Circuit breakers shall be provided with single phase and three phase auto reclosing. The short line fault capacity shall be same as the rated capacity and this is proposed to be achieved without use of opening resistors. Controlled switching device shall be provided in 400kV Circuit breakers of switchable line reactor bay and in Main & Tie bay circuit breakers of line with non-switchable line reactors and Bus reactors.

B.2.2.2 Isolators (AIS)

The isolators shall comply to IEC 62271-102 in general. 400kV isolator design shall be double break type. All isolators and earth switches shall be motor operated. Earth switches shall be provided at various locations to facilitate maintenance. Isolator rated for 400kV shall be of extended mechanical endurance class - M2 and suitable for bus transfer current switching duty as per IEC-62271-102. Main blades and earth blades shall be interlocked and interlock shall be fail safe type. 400kV earth switches for line isolator shall be suitable for induced current switching duty as defined for Class-B.

B.2.2.3 Current Transformers (AIS)

Current Transformers shall comply with IEC 61869 in general. All ratios shall be obtained by secondary taps only. Generally, Current Transformers (CT) for 400kV shall have six cores (four for protection and two for metering). The burden and knee point voltage shall be in accordance with the requirements of the system including possible feeds for telemetry. Accuracy class for protection core shall be PX and for metering core it shall be 0.2S. The rated burden of cores shall be closer to the maximum burden requirement of metering & protection system (not more than 20VA for metering core) for better sensitivity and accuracy. The instrument security factor shall be less than 5 for CTs upto 400kV voltage class.

B.2.2.4 Capacitive Voltage Transformers (AIS)

Capacitive Voltage transformers shall comply with IEC 61869 in general. These shall have three secondaries out of which two shall be used for protection and one for metering. Accuracy class for protection cores shall be 3P and for metering core it shall be 0.2. The Capacitive voltage transformers on lines shall be suitable for Carrier Coupling. The Capacitance of CVT for 400kV shall be of 4400/8800 pF depending on PLCC requirements. The rated burden of cores shall be closer to the maximum burden requirement of metering & protection system (not more than 50VA for metering core) for better sensitivity and accuracy.

B.2.2.5 Surge Arresters (AIS)

336 kV Station High (SH) duty gapless type Surge arresters with thermal energy (Wth) of minimum 12 kJ/kV conforming to IEC 60099-4 in general shall be provided for 400kV system. Other characteristics of Surge arrester shall be chosen in accordance with system requirements. Surge arresters shall be provided near line entrances, Transformers & Reactor so as to achieve proper insulation coordination. Surge Arresters shall be provided with porcelain/ polymer housing fitted with pressure relief devices. A leakage current monitor with surge counter shall be provided with each surge arrester.

B.2.3 Protection Relaying & Control System

The protective relaying system proposed to be provided for transmission lines, auto-transformers, reactors and bus bars to minimize the damage to the equipment in the events of faults and abnormal conditions, is dealt in this section. All main protective relays shall be numerical type with IEC 61850 communication interface and should have interoperability during integration of numerical relays to communicate over IEC61850 protocol with RTU/SAS/IEDs of different OEMs. All numerical relays shall have built in disturbance recording feature.

The protection circuits and relays of transformer and reactor shall be electrically and physically segregated into two groups each being independent and capable of providing uninterrupted protection even in the event of one of the protection groups failing, to obtain redundancy, and to take protection systems out for maintenance while the equipment remains in service.

a) Transmission Lines Protection

400kV lines shall have Main-I numerical three zone distance protection scheme with carrier aided inter-tripping feature. 400kV lines shall also have Main-II numerical distance protection scheme like Main-I but from different make that of Main-I. The Main-I and Main-II protection relays of same make may be provided only if they are of different hardware & manufacturing platform or different principle of operation.

However, Line Current Differential relay (with back up distance protection feature) as Main-I and Main-II shall be considered at both ends for short lines (line length below

30kM) having Fibre Optic communication link. Differential relay at remote end shall be provided by the TSP. Associated power & control cabling and integration with SAS at remote end shall be provided by respective bay owner.

In case of loop in loop out of transmission lines, the existing protection scheme shall be studied and suitable up-gradation (if required) shall be carried out.

Further, all 400kV lines shall be provided with single and three phase auto-reclosing facility to allow reclosing of circuit breakers in case of transient faults. These lines shall also be provided with distance to fault locators to identify the location of fault on transmission lines.

All 400kV lines shall also be provided with two stages over voltage protection. Over voltage protection & distance to fault locator may be provided as in-built feature of Main-I & Main-II protection relays. Auto reclose as built-in function of Bay Control Unit (BCU) is also acceptable.

The Main-I and Main-II protection relays shall be fed from separate DC sources and shall be mounted in separate panels.

For 400kV transmission lines, directional IDMT earth fault relay should be provided as standalone unit or in-built feature of Main-I and Main -II feature.

b) 400kV Reactor Protection

Reactor shall be provided with the following protections:

- i) Numerical Differential protection.
- ii) Numerical Restricted earth fault protection
- iii) Numerical Back-up impedance protection

Besides these, reactors shall also be provided with Buchholz relay, MOG with low oil level alarm, protection against oil and winding temperatures & pressure relief device, etc.

c) Bus bar Protection

The high speed low impedance type bus bar differential protection, which is essential to minimize the damage and maintain system stability at the time of bus bar faults, shall be provided for 400kV buses. Duplicated bus bar protection is envisaged for 400kV bus-bar protection. Bus bar protection scheme shall be such that it operates selectively for each bus and incorporate necessary features required for ensuring security. The scheme shall have complete bus bar protection for present as well as envisaged future bays i.e. input / output modules for future envisaged bays shall also be provided.

In case, the bus section is provided, then each side of bus section shall have separate set of bus bar protection schemes.

For existing substations, the existing bus bar protection shall be augmented as per requirement.

d) Local Breaker Back up Protection

This shall be provided for each 400kV circuit breakers and will be connected to de-energize the affected stuck breaker from both sides.

Notes:

1. *LBB & REF relays shall be provided separately from transformer differential relay.*
2. *LBB relay may also be provided as built-in protection function of distributed bus bar protection scheme; however in such case separate LBB relay shall be provided for tie bays (in case of One and Half breaker scheme).*
3. *Over fluxing & overload protection can be provided as built-in feature of differential relay.*
4. *In 400kV switchyard, if spare bay of half diameter is identified as future, Tie CB relay panel shall be with Auto-reclosure feature.*

B.2.4 Substation Automation System

- a)** For all the new substations, state of art Substation Automation System (SAS) conforming to IEC-61850 shall be provided. The distributed architecture shall be used for Substation Automation system, where the controls shall be provided through Bay control units. The Bay control unit is to be provided bay wise for voltage level 400kV and above. All bay control units as well as protection units are normally connected through an Optical fibre high speed network. The control and monitoring of circuit breaker, dis-connector, re-setting of relays etc. can be done from Human Machine Interface (HMI) from the Control Room.

The functions of control, annunciation, disturbance recording, event logging and measurement of electrical parameters shall be integrated in Substation Automation System.

At new substations, the Substation Automation System (SAS) shall be suitable for operation and monitoring of the complete substation including proposed future bays/elements.

In existing substations with Substation automation system (SAS), augmentation of existing SAS shall be done for bays under present scope.

In existing Substations where Substation automation is not provided, control functions shall be done through control panels.

Necessary gateway & modems (as required) shall be provided to send data to RLDC/SLDC as per their requirement. Any augmentation work at RLDC/SLDC is excluded from TSP's scope. However, all the configuration work at substation end required to send data to RLDC/SLDC shall be in the scope of TSP.

b) Time synchronization equipment

Time synchronization equipment complete in all respect including antenna, cable, processing equipment required to receive time signal through GPS or from National Physical Laboratory (NPL) through INSAT shall be provided at new substations. This equipment shall be used to synchronize SAS & IEDs etc.

B.3.0 Substation Support facilities

Certain facilities required for operation & maintenance of substations as described below shall be provided at new substation. In existing substation, these facilities have already been provided and would be extended/ augmented as per requirement.

B.3.1 AC & DC power supplies

For catering the requirements of three phase & single phase AC supply and DC supply for various substation equipment (for present and future scope), existing facilities shall be augmented as required.

B.3.2 Fire Fighting System

Fire-fighting system for substation including transformer & reactor shall conform to CEA (Measures Relating to Safety & Electric Supply) Regulations, 2023, as amended time to time.

Further, adequate water hydrants and portable fire extinguishers shall be provided in the substations. The main header of firefighting system shall be suitable for extension to bays covered under the future scope; necessary piping interface in this regard shall be provided.

At existing substations, the fire-fighting systems as available shall be extended to meet the additional requirements.

B.3.3 Oil evacuating, filtering, testing & filling apparatus

To monitor the quality of oil for satisfactory performance of transformers, shunt reactors and for periodical maintenance necessary oil evacuating, filtering, testing and filling apparatus would be provided at new substations. Oil storage tanks of adequate capacities for storage of transformer oil would be provided.

B.3.4 Illumination

Normal & emergency AC & DC illumination shall be provided adequately in the control room & other buildings of the substation. The switchyard shall also be provided with adequate illumination.

Lighting of the entire control room building, fire-fighting pump house, other building (if any) and switchyard shall be done by LED based low power consumption luminaries.

B.3.5 Control Room

For new substation, substation control room shall be provided to house substation work stations for station level control (SAS) alongwith its peripheral and recording equipment, AC & DC distribution boards, DC batteries & associated battery chargers, Fire Protection panels, Telecommunication panels & other panels as per requirements. Air conditioning shall be provided in the building as functional requirements. Main cable trenches from the control room shall have adequate space provision for laying of cables from control room for all the future bays also.

At existing substations, the adequacy of size of control room shall be ascertained and the same shall be augmented as per requirement.

B.3.6 Control Concept

All the EHV circuit breakers in substation/switching stations shall be controlled and synchronized from the switchyard control room/remote control center. All the isolators shall have control from remote/local whereas the earth switches shall have local control only.

B.3.7 Visual monitoring system (VMS) for watch and ward of substation premises:

Visual monitoring system for effective watch and ward of substation premises shall cover all the transformers and reactors, all other major AIS Equipment (such as CB, isolators, CT, CVT, SA etc. as applicable), GIS bays, panel room, all the gates of switchyard and all entry and exit points of control room building and accordingly the location of cameras shall be decided. The camera shall be high definition color CCD camera with night vision feature. The VMS data partly/completely shall be recorded (minimum for 15 days) at least @25fps (or better) and stored on network video recorder. The system shall use video signals from various cameras installed at different locations, process them for viewing on workstations/monitors in the control room and simultaneously record all the cameras.

Mouse/keyboard controllers shall be used for pan, tilt, zoom and other functions of the desired camera. The Visual Monitoring System shall have provision of WAN connectivity for remote monitoring.

All camera recordings shall have Camera ID & location/area of recording as well as date/time stamp. The equipment should generally conform to Electromagnetic compatibility requirement for outdoor equipment in EHV substation.

At existing substations, the visual monitoring system if available shall be augmented as per existing or better specification as required.

B.4.0 General Facilities

- a) Line Gantry/Towers are envisaged for bays under present scope only. However, for adjacent future line bay, tower shall be designed for extension (considering Quad conductors for 400kV future lines) wherever applicable.
- b) Bay extension works at existing substation shall be executed by TSP in accordance with the requirement/provisions mentioned above. However, interface points shall be considered keeping in view the existing design/arrangement at the substation.
- c) TSP has to arrange for construction power and water on its own.
- d) All outdoor steel structures including anchor/foundation bolts shall be fully galvanized. The weight of the zinc coating shall be at least 610 g/m². However, for coastal/creek regions it shall be at least 900 g/m².
- e) In 400kV switchyard, if spare bay of half diameter is identified as future, all the equipment for Tie & Future bay shall be designed considering the current rating of line bay i.e. 3150A.
- f) All electrical equipment shall be installed above Highest Flood Level and where such equipment is not possible to be installed above Highest Flood Level, it shall be ensured that there is no seepage or leakage or logging of water.

B.5.0 Extension of Existing Substation

The following drawings/details of existing substation is attached with the RFP documents for further engineering by the bidder.

Sl. No.	Drawing Title	Drawing No./Details	Rev. No.
A.	400kV Kallam S/S		
1.0	Single Line Diagram	Drawings for previous scheme are yet to be finalized by the developer.	-
2.0	General Arrangement		
3.0	Earthmat Layout		
4.0	Visual Monitoring System		
5.0	Bus Bar Protection		
6.0	Substation Automation System (SAS)		

Bidder is also advised to visit the substation sites and acquaint themselves with the topography, infrastructure such as requirement of roads, cable trench, drainage etc. and also the design philosophy.

SPECIFIC TECHNICAL REQUIREMENTS FOR COMMUNICATION

The communication requirement shall be in accordance to CEA (Technical Standards for Communication System in Power System Operations) Regulations, 2020, CEA (Technical Standards for Construction of Electrical Plants and Electric Lines) Regulations, 2022, CERC (Communication System for inter-State transmission of electricity) Regulations, 2017, and CEA (Cyber Security in Power Sector) Guidelines, 2021, all above documents as amended from time to time.

The complete ISTS communication system commissioned by TSP under the RFP shall be the asset of ISTS and shall be available for usage of ISTS requirements as suggested by CTU from time to time.

The protections for transmission line and the line compensating equipment shall have hundred percent back up communication channels i.e. two channels for tele- protection in addition to one channel for speech plus data for each direction.

In order to meet the requirement for grid management and operation of substations, Transmission Service Provider (TSP) shall provide the following:

C.1.0 LILO of both circuits of Parli(M) – Karjat(M)/Lonikand-II (M) 400 kV D/c line (twin moose) at Kallam PS.

On LILO of both circuits of 400 kV D/c Parli (M) – Karjat(M)/ Lonikhand-II (M) 400 kV D/c line (twin moose) at Kallam S/s, TSP shall supply, install & commission OPGW and earthwire as per Tower Configurations:

- (i) For Multi Circuit Tower Configuration: Two (2) no. OPGW cable containing 24 Fibres (24F) to be installed & commissioned by the TSP on both the Earthwire peaks
- (ii) For Double Circuit Tower configuration (for both Loop In and Loop Out portion): One (1) no. OPGW cable containing 24 Fibres (24 F) on one earthwire peak & conventional earthwire on other E/W peak for both Loop In and Loop Out Lines.

The TSP shall install OPGW cables from gantry of Kallam S/s up to the LILO tower with all associated hardware including Vibration Dampers, mid-way & gantry Joint Boxes (called OPGW Hardware hereafter) and finally terminate in Joint Boxes at Kallam S/s. The transmission line length is **15 kms (approx.)**. After LILO, if fiber length for links Parli (M) to Kallam PS and Kallam PS to Lonikhand (M) is above 225 kms then repeater shall be envisaged, otherwise line can be managed as a repeater less link.

TSP shall finalize the location of repeater station depending upon the actual site conditions. Further TSP shall comply to the requirements mentioned as per **Appendix-F.1**

Maintenance of OPGW Cable, OPGW Hardware & repeater equipment & items associated with repeater shelter shall be responsibility of TSP.

C.2.0 4 Nos. 400 kV line bays at Kallam PS for LILO of both circuits of Parli(M) – Karjat(M)/ Lonikand-II(M) 400 kV D/c line (twin moose) at Kallam PS

- (i) TSP shall supply, install & commission 1 no. FODP (72F or higher) alongwith panel and required Approach Cable (24F) with all associated hardware fittings from gantry tower to Bay Kiosk and from the Bay Kiosk to Control room.
- (ii) TSP shall supply, install & commission One STM-16 (FOTE) equipment alongwith panel/s supporting minimum three (3) directions with MSP (Multiplex Section Protection – 1+1) with necessary interfaces to meet the voice and data communication requirement among **Kallam S/s, Parli (M) S/s and Karjat(M)/ Lonikand-II (M) S/s**. The suitable DC Power Supply and backup to be provided for communication equipment.
- (iii) FOTE/FODP panel shall be installed in the new Bay Kiosk. The FOTE under present scope shall be integrated by TSP with the existing FOTE at control room of **Kallam S/s** which shall be communicating with respective control center. TSP to provide necessary FODP sub rack / Splice trays/ Patch cords etc. and optical interfaces/equipment in the existing FOTE/FODP panels in control room for integration with the existing FOTE for onwards data transmission.

In case spare optical direction is not available in the existing FOTE at the control room, the TSP shall coordinate with station owner to reconfigure the directions in existing FOTE at control room. Alternatively, The TSP may integrate the FOTE under the present scope with existing FOTE in the nearby Kiosk connected to the control room FOTE (if available with spare direction). For this purpose, TSP shall provide necessary FODP sub rack / Splice trays/ Patch cords etc. and suitable optical interfaces/ equipment in the existing FOTE/FODP panels in another Kiosk (SPR).

- (iv) FOTE & FODP can be accommodated in same panel to optimize space.
- (v) The new communication equipment under the present scope shall be compatible for integration with existing regional level centralized NMS. The local configuration of the new communication equipment shall be the responsibility of TSP. The configuration work in the existing centralized NMS for integration of new Communication equipment shall be done by Regional ULDC Team, however all the necessary support in this regard shall be ensured by TSP.
- (vi) The maintenance of all the communication equipment and software thereof including FOTE, PMU, FODP, approach cable, DCPS alongwith Battery Bank shall be the responsibility of TSP.

C.3.0 Specific Requirement for Phasor Measurement Units (PMUs)

TSP shall supply, install & commission required no. of Phasor Measurement Units (PMUs) PMUs at all the locations under the scope of TSP under this RFP as per CEA (Technical Standards for Construction of Electrical Plants and Electric Lines) Regulations, 2022 (alongwith all amendments if any), and all the applicable Regulations, Standards, Guidelines issued time to time. These PMUs shall be provided

with GPS clock and LAN switch and shall connect with LAN switch of control room of respective substations/ generating stations with Fibre Optic cable. These PMUs shall be connected with the FOTE at Substation/ generating stations for onwards data transmission to the PDC (Phasor Data Concentrator) located at respective RLDC. Configuration work in existing PDC at RLDC for new PMU integration shall be done by respective RLDC, however all the necessary support in this regard shall be ensured by TSP. The maintenance of all the PMUs and associated equipment shall be the responsibility of TSP.

Note: Existing Station owner/s to provide necessary support to integrate different equipment & applications of new extended bays with the existing substation e.g. Communication (through FOTE), Voice etc. for smooth operation and monitoring of new added grid elements.

Appendix-F.1

Repeater Requirements

- If the repeater location is finalized in the Control Room of a nearby substation, TSP shall provide 1 no. OPGW (48F) on a single Earthwire peak with OPGW Hardware & mid-way Joint Boxes etc. of the line crossing the main line and 1 no. Approach Cable (48F) with all associated hardware fittings, to establish connectivity between crossing point of main transmission line up to the repeater equipment in substation control room. TSP shall co-ordinate for Space & DC power supply sharing for repeater equipment. TSP shall provide FODP, FOTE (with STM-16 capacity) with suitable interfaces require for link budget of respective link.

OR

- If the repeater location is finalized in the nearby substation premises, the TSP shall identify the Space for repeater shelter in consultation with station owner. Further TSP shall provide 1 no. OPGW (48F) on a single Earthwire peak with OPGW Hardware & mid-way Joint Boxes etc. of the line crossing the main line and 1 no. Approach Cable (48F) / UGFO (48F) with all associated hardware fittings, to establish connectivity between crossing point of main transmission line up to the substation where the repeater shelter is to be housed.

TSP shall provide repeater shelter along with FODP, FOTE (with STM-16 capacity) with suitable interfaces require for link budget of respective link, reliable power supply provisioning for AC and DC supply, battery bank, Air Conditioner and other associated systems.

OR

- If the repeater location is finalized on land near the transmission tower. TSP shall make the provisions for Land at nearby tower for repeater shelter. Further TSP shall provide 1 no. Approach Cable (48F) / UGFO (48F) with all associated hardware fittings to establish connectivity up to the location of repeater shelter. TSP shall provide repeater shelter along with FODP, FOTE (with STM-16 capacity) with suitable interfaces require for link budget of respective link, reliable power supply provisioning for AC and DC supply, battery bank, Air Conditioner and other associated systems

Maintenance of OPGW Cable and **OPGW Hardware**, repeater equipment & items associated with repeater shelter shall be responsibility of TSP.

Proposed Communication for Transmission Scheme for Western Region Network Expansion scheme in Kallam area of Maharashtra

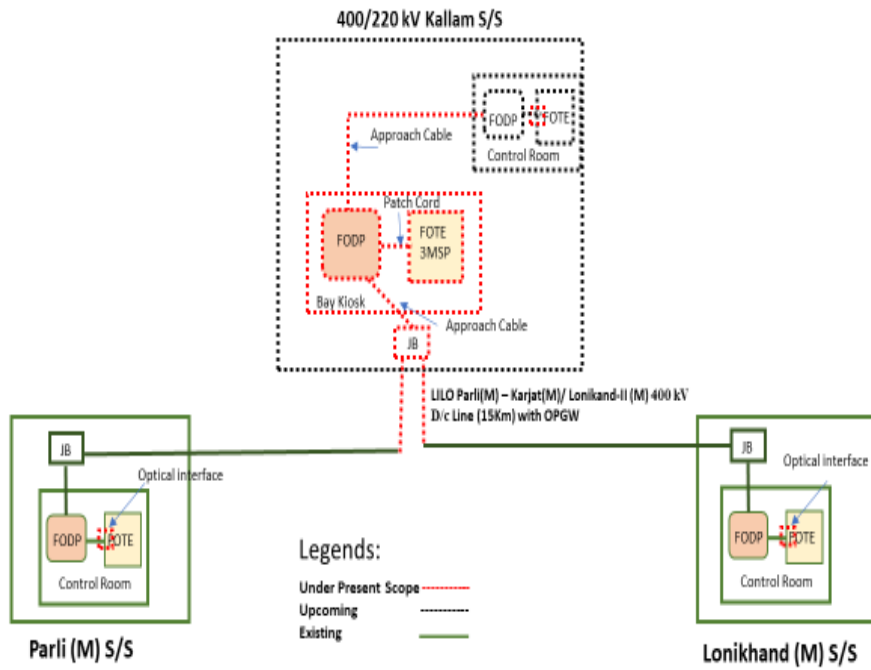

C.4.0 PLCC & PABX:

Power line carrier communication (PLCC) equipment complete for speech, tele-protection commands and data channels shall be provided on each transmission line.. The PLCC equipment shall in brief include the following: -

- Coupling device, line traps, carrier terminals, protection couplers, HF cables, PABX (if applicable) and maintenance and testing instruments.
- Coupling devices shall be suitable for phase-to-phase coupling for 400kV Transmission lines. The pass band of coupling devices shall have sufficient margin for adding communication channel in future if required. Necessary protection devices for safety of personnel and low voltage part against power frequency voltages and transient over voltage shall also be provided.
- The line traps shall be broad band tuned suitable for blocking the complete range of carrier frequencies. Line Trap shall have necessary protective devices such as lightning arresters for the protection of tuning device. Decoupling network consisting of line traps and coupling capacitors may also be required at certain substation in case of extreme frequency congestion.
- The carrier terminals shall be of single side-band (SSB) amplitude modulation (AM) type and shall have 4 kHz band width. PLCC Carrier terminals and Protection couplers shall be considered for both ends of the line.
- TSP shall provide/ undertake necessary addition/ modification/ shifting/ re-commissioning etc. of PLCC equipment due to LILO of transmission lines (wherever applicable).

- LILO of both circuits of Parli(M) –Karjat(M)/Lonikand-II(M) 400kV D/c line at Kallam PS:

Sl. No	Line name	PLCC configuration
1	Parli(M) – Kallam 400kV D/c line.	1 set Analog PLCC + 1 set Digital Protection Coupler for each circuit at each end.
2	Karjat(M)- Kallam & Lonikand-II(M)-Kallam line	1 set Analog PLCC + 1 set Digital Protection Coupler for each circuit at each end.
Existing PLCC panels of Parli(M) –Karjat(M)/Lonikand-II(M) 400kV D/c line may also be utilized.		

- All other associated equipment like CVT, Line Trap, cabling, coupling device and HF cable shall also be provided by the TSP

Frequently Asked Queries:**1.0 Transmission Line:**

1.1 Please clarify that whether shutdowns for crossing of existing transmission lines of POWERGRID/STUs/ Power Evacuation Lines from Generation Plants/ Any other Transmission Licensee will be given to TSP on chargeable basis or free of cost.

Reply: Shutdowns for crossing of existing transmission lines of POWERGRID/ STUs/ Power Evacuation Lines from Generation Plants/ Any other Transmission Licensee will be given to TSP by the concerned owner of the lines as per their own terms & conditions. As far as shutdown of ISTS lines are concerned the same can be availed by approaching respective Regional Power Committee.

1.2 We understand that the suggested swing angle criteria are applicable for Suspension Insulator in Suspension Tower. Further, you are requested to provide similar swing angle and clearance criteria for Pilot Insulator with Jumper & Jumper.

Reply: It is clarified that the swing angle criteria (as mentioned in RFP) for transmission lines is applicable for Suspension Insulator in Suspension Tower. Further, as per Clause 3.0 of Specific Technical Requirements for transmission lines, Transmission service Provider (TSP) shall adopt any additional loading/design criteria for ensuring reliability of the line, if so desired and /or deemed necessary.

1.3 We request you to kindly allow that use of diamond configuration at Power line crossings and the existing owner of the lines may be directed to allow the same for the successful bidders.

Reply: Power line crossing including Diamond configuration is responsibility of the TSP. TSP shall formally submit the profile of the crossing section to the owner of the existing line suggesting proposed crossing alternatives. The crossing will have to be carried out as per approval of owner of the existing line.

1.4 It is requested you to kindly provide present status of Forest Clearances if any transmission line corridor area falling in wildlife forest / reserve forest/ mangroves.

Reply: Based on the preliminary route survey, the process of initiation of forest clearance for the forest stretches, if any, enroute the proposed line alignment will be initiated by way of writing letters to the concerned authority (ies). However, it may be noted that it will be the responsibility of TSP for obtaining

forest clearance for the forest stretches as provided in the survey report and also for any forest area encountered during detailed survey.

2.0 **Substation**

2.1 We understand that space for storage of O&M spare shall be provided by existing owner within the station boundary without any cost. Kindly confirm.

Reply: Space for storage of O&M spares shall be arranged by TSP on its own.

2.2 We presume that the O&M for the end Termination bays will be in the scope of the TSP and TSP shall not be liable for any payment towards O&M to the existing owner of the substation. Kindly confirm.

Reply: Operation and maintenance of the bays is solely responsibility of the TSP. TSP shall follow CEA's "Operation and Maintenance (O&M) guidelines and Standard Format for Memorandum of Understanding between New TSP and Existing TSP" issued by CEA vide its letter No. I/28514/2023 dated 22.06.2023. Copy of the guideline is available on CEA website at following link:

https://cea.nic.in/wp-content/uploads/pse_td/2023/06/om_guidelines.pdf

2.3 With reference to subject scheme of existing sub-station, we assumed following scope of work:

- (a) We assumed internal road is available and need not to consider in the present scope of work.
- (b) Drainage is available and need not to consider in the present scope of work.
- (c) Cable trench extension in adjacent to Main cable trench only under present scope of work.
- (d) Levelled area being provided by developer for bay extension.

Reply: Regarding requirement of internal road, drainage, cable trench, leveling of the bay extension area, bidder is advised to visit site and acquaint themselves with the provisions/facilities available at substation.

2.4 Kindly provide the soil investigation report of soil parameters of existing substation.

Reply: Bidder is advised to visit the substation site and ascertain the requisite parameters.

2.5 Kindly confirm, energy accounting of aux. power consumption. Whether it will be on chargeable basis or part of transmission loss.

Reply: It will be on chargeable basis.

2.6 We understand that VMS requirement is for unmanned stations only. For Manned stations VMS is not compulsory.

Reply: VMS shall be provided in line with requirements of RfP document.

2.7 It is understood that Construction water and power shall be provided free of cost to TSP by respective substation owner for construction of new bays.

Reply: Arrangement of construction power & water is in the scope of TSP.

2.8 It is understood that existing fire hydrant system shall be extended by the TSP for bay extension.

Reply: Existing fire hydrant system shall be extended from existing system (if required)

2.9 Please clarify that Status of land acquisition for Substations. Whether the lands have been acquired by BPC and will be transferred to TSP.

Reply: The acquisition of land for substation is in the scope of TSP.

2.10 We understood that no any dedicated metering CT & CVT required for Line/feeders. Further, we understood that requisite Energy meters for various 765kV, 400kV & 220kV Feeders shall be provided & installed by CTU free of cost to TSP.

Reply: Dedicated metering CT and CVT are not required for line/feeders. Metering core of existing CT/CVT can be used provided accuracy class is matching with metering requirement. Requisite Special Energy Meters shall be provided and installed by CTU at the cost of TSP in C&P panel subject to space availability, else, in separate metering panel (to be provided by TSP at its cost).

2.11 It is understood that TSP to follow the RFP for Technical Requirement. Only interface drawings like CRP & SCADA shall be coordinated with existing S/S owner.

Reply: All necessary coordination shall be done with exiting s/s owner w.r.t interface along with augmentation required as per RfP.

2.12 We understand that there are only two communication channels, Chanel-1 for protection-1+ Speech via. PLCC, Chanel-2 for Protection-2 + data via. FOTE. Hence, we do not envisage any separate channel for speech + data as the same can be achieved with FOTE system. Therefore, we understand that TSP is allowed to implement best possible solutions accordingly. Kindly confirm

Reply: PLCC equipment for all the transmission lines covered under the scheme (consisting of one set of analog PLCC channel along with circuit protection coupler and one set of Digital protection coupler for both ends) shall be

provided by TSP. Further, OPGW based terminal equipment shall be utilized for Speech+ Data.

2.13 We understand that one set of analog circuit protection coupler shall be for PLCC and another set for Digital protection coupler for FOTE. Kindly confirm.

Reply: PLCC equipment for all the transmission lines covered under the scheme (consisting of one set of analog PLCC channel along with circuit protection coupler and one set of Digital protection coupler for both ends) shall be provided by TSP. Further, OPGW based terminal equipment shall be utilized for Speech+ Data.

3.0 Communication

3.1 What are the usage of OPGW, FOTE, PMU etc. under communication requirement of RFP?

Reply: User shall be responsible for providing compatible equipment along with appropriate interface for uninterrupted communication with the concerned control center and shall be responsible for successful integration with the communication system provided by CTU.

Communication systems e.g. OPGW, FOTE, PMU etc. are required for grid operation through RLDC/SLDC, speech communication, tele-protection and tele-metering.

3.2 Is space for installation of communication panels are provided to TSP in existing Substations incase new bays are in the scope of TSP?

Reply: The space replated issues are deliberated in the RFP itself. TSP to carry out survey of the existing substation for physical space requirement. In case space is not available in the existing substation then TSP shall accommodate the same in the respective bay SPR (Switchyard Panel Room)/Bay Kiosk/ Relay panel room in case of GIS s/s. Further, TSP to connect and integrate the proposed FOTE with the existing FOTE in the Relay Panel Room.

In Case 132kV Substation TSP shall accommodate the said panels either by extension of existing Relay Panel Room or other arrangements.

3.3 How is the OPGW laying done in case of LILO lines?

Reply: In case LILO lines are on same towers (e.g. both Line in and Line Out portion are on same towers, generally done LILO of S/C lines). Then 2x24F OPGW shall be required to install by TSP on both earthwire peak on 400kV & 765kV lines where two E/W peaks are available. On 220 & 133kV lines where only one E/W peak is available TSP to install one no. 48F OPGW.

Incase LILO lines are on different towers (e.g. both Line In and Line Out portion are on different towers, generally done LILO of D/C lines). Then 1x24F OPGW shall be required to install by TSP on one earthwire peak, on both Line In and Line Out portions of 400kV & 765kV lines. On 220 & 133kV lines where only one E/W peak is available TSP to install one no. 24F OPGW in place of conventional earthwire.

3.4 How is the OPGW laying done in case Multi circuit Towers?

Reply: In case two different lines are using common multi circuit portion for some distance (originating from different stations, may be terminating on same or on different stations). Two no. 24F OPGW to be installed on both E/W peaks for common M/C portion of 765kV & 400kV lines.

Incase 220/132kV lines using multi circuit portion where single E/W peak is available one no. 48F may be installed for common multi circuit portion.

SHARE PURCHASE AGREEMENT

BETWEEN

REC POWER DEVELOPMENT AND CONSULTANCY LIMITED

AND

Name of the SPV

AND

[Insert name of the Selected Bidder]

Dated: [insert date]

SHARE PURCHASE AGREEMENT

This **SHARE PURCHASE AGREEMENT** ('Agreement') made this _____ day of _____ *[Insert Date of the Agreement]* 2023 at New Delhi by and between:

REC POWER DEVELOPMENT AND CONSULTANCY LIMITED, a company incorporated under the Companies Act, 1956, having its registered office at Core 4, SCOPE Complex, 7, Lodhi Road, New Delhi 110 003, India (hereinafter referred to as "**REC PDCL**", which expression shall, unless it be repugnant to the context or meaning thereof, be deemed to mean and include its successors and permitted assigns) of the **FIRST PART**;

AND

{Name of the SPV}, a company incorporated under the Companies Act, 2013, having its registered office at Core 4, SCOPE Complex, 7, Lodhi Road, New Delhi 110 003, India (hereinafter referred to as "**Company**" which expression shall, unless repugnant to the context, mean and include its successors in interest) of the **SECOND PART**; and

AND

_____ *[Insert Name of the Selected Bidder]* a company incorporated under the Companies Act, 1956 having its registered office at _____ *[Insert the registered office address of the Selected Bidder]* (hereinafter referred to as "**Selected Bidder**" which expression shall, unless repugnant to the context or meaning thereof, be deemed to mean and include its successors and permitted assigns) of the **THIRD PART**.

Note: [In case the Selected Bidder is a Bidding Consortium, the above immediate paragraph shall be replaced by the following:

..... *[Insert Name of the Lead Member]*, a company incorporated under the Companies Act, 1956 and having its registered office at *[Insert the registered office address of Lead Member]*

AND

..... *[Insert Name of the Member]*, a company incorporated under the Companies Act, 1956 and having its registered office at *[Insert the registered office address of Member]* (hereinafter individually referred to as "**Partner 1**" and "**Partner 2**" respectively and collectively referred to as "**Selected Bidder**" which expression shall, unless repugnant to the context or meaning thereof, be deemed to mean and include its successors and permitted assigns) of the **THIRD PART**

WHEREAS:

- A. The Ministry of Power, Government of India, vide its notification [F. No. CEA-PS-12-13/3/2022-PSPA-II Division] dated 10.08.2023 has appointed REC Power Development and Consultancy Limited to be the Bid Process Coordinator (BPC) for the purpose of selection of Bidder as Transmission Service Provider (TSP) to establish transmission system for “**Western Region Network Expansion Scheme in Kallam area of Maharashtra.**” through tariff based competitive bidding process.
- B. In accordance with the Bidding Guidelines, the BPC had initiated a competitive bidding process through issue of RFP for selecting a Successful Bidder to build, own, operate and the Project comprising of the Elements mentioned in **Schedule 2** of the TSA. BPC had initiated this process in accordance with and on the terms and conditions mentioned in the RFP Project Documents (as defined hereinafter).
- C. BPC has incorporated the Company and has undertaken the preliminary studies, obtained certain approvals, etc. regarding the Project on behalf of the Company
- D. REC PDCL along with the Nominees hold one hundred per cent (100%) of the total issued and paid-up equity share capital of the Company.
- E. Pursuant to the said Bid Process, _____ **[Insert Name of the Selected Bidder]** has been identified as the Selected Bidder vide Letter of Intent dated _____ **[Insert Date of the Letter of Intent]** issued by the BPC in favour of the Selected Bidder.
- F. As envisaged in the RFP, the Shares Seller (as defined hereinafter) has agreed to sell the Sale Shares (as defined hereinafter) to the Selected Bidder and the Selected Bidder has agreed to purchase the Sale Shares from the Shares Seller, subject to and on the terms and conditions set forth in this Agreement.

NOW THEREFORE, IN CONSIDERATION OF THE MUTUAL COVENANTS AND AGREEMENTS SET FORTH IN THIS AGREEMENT AND FOR OTHER GOOD AND VALUABLE CONSIDERATION, THE PARTIES HEREBY AGREE AS FOLLOWS:**1. DEFINITIONS**

- 1.1 Capitalised terms in this Agreement, unless defined in this Agreement shall, in so far as the context admits, have the same meaning in this Agreement as has been ascribed to them in the TSA.
- 1.2 Additionally, the following terms shall have the meaning hereinafter respectively assigned to them herein below:

- (i) **“Acquisition Price”** shall mean INR _____ (Rupees _____ only) [*Insert the value of the Acquisition Price, both in figures and in words respectively*], which is the aggregate consideration payable by the Selected Bidder towards purchase of the Sale Shares at par and for taking over of all assets and liabilities of the Company as on the Closing Date subject to adjustment as per the audited accounts of the Company as on the Closing Date;
- (ii) **“Agreement”** or **“the Agreement”** or **“this Agreement”** shall mean this Share Purchase Agreement and shall include the recitals and/or annexures attached hereto, and the contracts, certificates, disclosures and other documents to be executed and delivered pursuant hereto, if any, and any amendments made to this Agreement by the Parties in writing;
- (iii) **“Bid Process”** shall mean the competitive bidding process initiated by the BPC, by issuance of RFP for selecting a Successful Bidder to build, own, operate and transfer the Project in accordance with and on the terms and conditions mentioned in the RFP Project Documents;
- (iv) **“Board”** shall mean the board of directors of the Company;
- (v) **“Closing Date”** shall mean a mutually agreed date between the Parties falling within the period as mentioned in clause 2.15.2 of RFP or on failure of such mutual agreement between the Parties shall be the date falling on the last date of such period;
- (vi) **“Encumbrance”** shall mean any mortgage, pledge, lien, charge, security assignment, hypothecation, trust, encumbrance or any other agreement having the effect of creating security interest;
- (vii) **“Letter of Intent”** shall have the meaning ascribed thereto under the Bid Documents;
- (viii) **“Nominees”** shall mean the Persons, who are named in **Annexure A** of this Agreement, holding the Sale Shares as nominees of RECPDCL;

- (ix) **“Party”** shall mean REC PDCL, Company and the Selected Bidder, referred to individually, and **“Parties”** shall mean REC PDCL, Company and the Selected Bidder collectively referred to, as relevant;
- (x) **“Person”** shall include an individual, an association, a corporation, a partnership, a joint venture, a trust, an unincorporated organisation, a joint stock company or other entity or organisation, including a government or political subdivision, or an agency or instrumentality thereof, and/or any other legal entity;
- (xi) **“RFP Project Documents”** shall mean the following documents, referred to collectively:
- a) Transmission Service Agreement; and
 - b) this Agreement.
- (xii) **“Representations and Warranties”** shall mean the representations and warranties mentioned in **Clause 4** hereto;
- (xiii) **“RoC”** shall mean the Registrar of Companies;
- (xiv) **“Sale Shares”** shall mean _____ [Insert total number of shares of the Company] shares, representing one hundred percent (100%) of the total issued, subscribed and fully paid-up equity share capital of the Company held by the Shares Seller and Nominees as more particularly described in **Annexure A** attached hereto;
- (xv) **“Shares”** shall mean the fully paid-up equity shares of Company, of face value Rs. 10 each;
- (xvi) **“Shares Seller”** shall mean REC PDCL; and
- (xvii) **“Transmission Services Agreement”** or **“TSA”** means the agreement titled ‘Transmission Services Agreement dated _____ [Insert Date of the TSA] entered into between the Central Transmission Utility of India Limited (CTUIL) and [Insert name of the SPV] pursuant to which the TSP shall build, own, operate and Transfer the Project and make available the assets of the Project on a commercial basis.

1.3 Interpretation Clause

Unless the context otherwise requires, the provisions of the TSA relating to the interpretation of the TSA shall apply to this Agreement as if they were set out in full in this Agreement and to this end are incorporated herein by reference.

2. TRANSFER OF SHARES

- 2.1 Subject to the terms and conditions of this Agreement, the Shares Seller agrees to sell and transfer to the Selected Bidder and the Selected Bidder hereby agrees to purchase from the Shares Seller, the Sale Shares free from Encumbrances together with all assets and liabilities of the Company with rights and benefits attached thereto in consideration of the Acquisition Price and the covenants, undertakings and the agreements of the Selected Bidder contained in this Agreement.
- 2.2 The Shares Seller hereby undertakes to cause the Nominees to transfer part of the Sale Shares held by them as nominees of the Shares Seller to the Selected Bidder and execute any documents required to deliver good title to the Sale Shares to the Selected Bidder.

3. CLOSING

- 3.1 Prior to the Closing Date, the Selected Bidder shall provide to the Shares Seller, valid share transfer forms duly stamped with requisite amount of stamp duty payable on the transfer of the Sale Shares ("**Share Transfer Forms**").
- 3.2 On the Closing Date, the Shares Seller shall hand over to the Selected Bidder or its authorised representative, the original share certificates representing the Sale Shares ("**Sale Share Certificates**") executed by the Shares Seller and the Nominees, simultaneously against the Selected Bidder handing over to the Shares Seller, demand drafts drawn in favour of the Shares Seller or by confirmation of RTGS transfer in favour of the Shares Seller, for the Acquisition Price payable to it.

Provided that prior to the handing over of the Sale Share Certificates to the Selected Bidder as mentioned above, the Selected Bidder shall provide satisfactory evidence to REC PDCL that on the Closing Date, the Selected Bidder has furnished the Contract Performance Guarantee to the Central Transmission Utility of India Limited (CTUIL) and is in a position to comply with all other requirements of Clause 2.15.2 of the RFP.

- 3.3 The Selected Bidder shall immediately upon receiving the Sale Share Certificates and the Share Transfer Forms, duly execute the Share Transfer Forms and duly lodge the Share Transfer Forms and the Share Certificates with the Company along with the names of its nominees to be appointed on the Board of the Company and the address within the jurisdiction of the RoC of New Delhi and Haryana, which would be the new registered office of the Company. The Company shall, upon receipt of the said documents from the Selected Bidder, do the following:
- (i) Immediately on the Closing Date convene a meeting of the Board, wherein the Board shall pass the following necessary resolutions:

- (a) approving the transfer of the Shares constituting the Sale Shares from the Shares Seller and the Nominees to the name of the _____ [Insert Name of the Selected Bidder] and transfer of all assets and liabilities of the Company as on Closing Date;
- (b) approving the _____ [Insert Name of the Selected Bidder] as a member of the Company and entering the name of the _____ [Insert Name of the Selected Bidder] and its nominees in the register of members.
- (c) changing the address of the registered office of the Company to the new address as provided by the Selected Bidder as per clause 3.3 above.
- (d) appointing the nominees of the Selected Bidder on the Board and accepting the resignations of the other existing Directors on the Board and the Chair of the meeting which was taken by one of the existing Directors shall be vacated and appointment of a new Chairman who shall be one of the newly appointed Director, for the rest of the meeting.

Immediately pursuant to the acceptance of resignation of the existing Directors and appointment of new Chairman, the newly constituted Board of Directors shall continue with the meeting and pass the following resolution:

- (e) terminating all the authorizations granted regarding the business and/or operations of the Company or the operations of the bank accounts of the Company, with prospective effect; and
 - (f) acknowledging and accepting the terms and conditions as contained in the executed copies of the RFP Project Documents and to abide by the provisions contained therein.
- (ii) Enter the name of the _____ [Insert Name of the Selected Bidder] and its nominees as the legal and beneficial owner of the Sale Shares, free of all Encumbrances, in the register of members of the Company;
 - (iii) Make the necessary endorsements on the Sale Share Certificates, indicating the name of the _____ [Insert Name of the Selected Bidder] and its nominees as the legal and beneficial owner of the Sale Shares evidenced there under;

- (iv) Return the original Sale Share Certificates, duly endorsed in the name of the _____ [Insert Name of the Selected Bidder] and its nominees, to the _____ [Insert Name of the Selected Bidder] and its nominees, as the case may be or its authorised representative;
- (v) Handover all the statutory registers and records, if any, of the Company to the Selected Bidder.
- (vi) Handover certified true copies of the Board resolution passed by the Company as per (i) (a) to (i) (f) of Clause 3.3 (i) to the Central Transmission Utility of India Limited (CTUIL)
- 3.4 The Parties to this Agreement agree to take all measures that may be required to ensure that all the events contemplated in the **Clauses 3.1 to 3.3** above on the Closing Date are completed on the same day.

Notwithstanding the provisions of **Clause 3.3** hereto, all proceedings to be taken and all documents to be executed and delivered by the Parties at the Closing Date shall be deemed to have been taken and executed simultaneously and no proceedings shall be deemed to have been taken nor documents executed or delivered until all have been taken, executed and delivered.

- 3.5 The Selected Bidder hereby acknowledges and agrees that after the date of acquisition of one hundred percent (100%) of the Shares of the Company by the Selected Bidder as per Clause 3.3, (a) the authority of the BPC in respect of the Bid Process shall forthwith cease and any actions to be taken thereafter regarding the Bid Process will be undertaken by the Central Transmission Utility of India Limited (CTUIL), (b) all rights and obligations of the BPC shall cease forthwith, (c) all other rights and obligations of the Company shall be of the TSP and (d) any decisions taken by the BPC on behalf of the Company prior to the date of acquisition, shall continue to be binding on the Company and/or Central Transmission Utility of India Limited (CTUIL) as the case may be.
- 3.6 This Agreement shall be effective from the date of its signing by the Parties and shall remain in force until all the obligations of the respective Parties under Clause 3.3 hereto are fulfilled.

4. REPRESENTATIONS AND WARRANTIES

- 4.1 The Selected Bidder hereby represents and warrants to the Shares Seller that:
- 4.1.1 The Selected Bidder has full legal right, power and authority to enter into, execute and deliver this Agreement and to perform the obligations, undertakings and transactions set forth herein, and this Agreement has been duly and validly executed and delivered by the Selected Bidder and constitutes its legal, valid and binding obligations, enforceable against it in accordance with its terms;

- 4.1.2 The execution, delivery and performance of this Agreement by the Selected Bidder will not violate or contravene any provision of the Memorandum of Association or Articles of the Selected Bidder, (ii) will not violate or contravene any law, statute, rule, regulation, licensing requirement, order, writ, injunction or decree of any court, governmental instrumentality or other regulatory, governmental or public body, agency or authority by which the Selected Bidder is bound or by which any of its and/or their properties or assets are bound, and (iii) except to the extent that the same have been duly and properly completed or obtained, will not require any filing with, or permit, consent or approval of or license from, or the giving of any notice to, any court, governmental instrumentality or other regulatory, governmental or public body, agency or authority, joint venture party, or any other entity or person whatsoever; and
- 4.1.3 The Selected Bidder is not restricted in any manner whatsoever, including without limitation, on account of any judicial or governmental order, action or proceeding, or any contractual obligation assumed by the Selected Bidder, from purchasing the Sale Shares from the Shares Seller in the manner provided for in this Agreement.
- 4.2 The Shares Seller hereby represents and warrants to the Selected Bidder that;
- 4.2.1 The Shares Seller and the Nominees are the legal and beneficial owners of the Sale Shares, free and clear of any Encumbrance and the delivery to the Selected Bidder of the Sale Shares pursuant to the provisions of this Agreement will transfer to the Selected Bidder a good title to the Sale Shares.
- 4.2.2 The Shares Seller has full legal right, power and authority to enter into, execute and deliver this Agreement and to perform the obligations, undertakings and transactions set forth herein. The execution, delivery and performance of this Agreement will not violate the Memorandum and Articles of Association of the Shares Seller or contravene any contract by which it is bound.
- 4.2.3 The Shares Seller has obtained requisite authorizations to sell and transfer the Sale Shares to the Selected Bidder. The Shares Seller also represent that it is not prevented from transferring and selling the Sale Shares. Also, to the best of its knowledge, the Sale Shares are not the subject matter of any claim or pending proceeding or threatened by any legal proceeding made by any third party.

- 4.3 Except as specified in Clause 4.2 above, the Shares Seller shall not be deemed to have, made any representation or warranty whatsoever, whether express or implied, in relation to the Sale Shares or Company, including but not limited to any implied warranty or representation as to the business or affairs of Company.
- 4.4 The Representations and Warranties are given as at the date of this Agreement except that where a Representation and Warranty is expressed to be made as at another date, the Representation and Warranty is given with respect to that date only.
- 4.5 Each Representation and Warranty is to be construed independently of the others and is not limited by reference to any other Warranty. The Representations, Warranties and undertakings contained in this **Clause 4** hereto or in any document delivered pursuant to or in connection with this Agreement are continuing in nature and shall survive the Closing Date for a period of one (1) year.
- 4.6 The Parties represent to each other that all Representations and Warranties provided herein by the respective Party shall be true as of Closing Date.

5. OBLIGATIONS OF THE SELECTED BIDDER

The Selected Bidder agrees that the Shares Seller shall not be liable in any manner, nor shall it assume any responsibility or liability whatsoever, in respect of the business of the Company and its operations or activities, arising after the Closing Date, to any Person or any authority, central, state, local or municipal or otherwise and the same shall be the sole responsibility of the Selected Bidder.

6. MISCELLANEOUS

6.1 NOTICES

- a) All notices to be given under this Agreement shall be in writing and in the English language.
- b) All notices must be delivered personally or by registered or certified mail or by recognised courier to the addresses below:

Selected Bidder: _____ *[Insert details of the address for correspondence (Lead Member in case of Consortium)]*

REC PDCL: **REC Power Development and Consultancy Limited**

Core-4, SCOPE Complex, 7, Lodhi Road,
New Delhi-110003

Company: **{Insert Name of the SPV}**
Core-4, SCOPE Complex, 7, Lodhi Road,
New Delhi-110003

- c) Any Party may by notice of at least fifteen (15) days to the other Parties change the address and / or addresses to which such notices and communications to it are to be delivered or mailed.

6.2 RESOLUTION OF DISPUTES

- 6.2.1 If any dispute arises between the Parties, in connection with the validity, interpretation, implementation or alleged breach of any provision of this Agreement (“Dispute”), the disputing Parties hereto shall endeavour to settle such Dispute amicably. The attempt to bring about an amicable settlement shall be considered to have failed if not resolved within sixty (60) days from the date of the Dispute.
- 6.2.2 If the Parties are unable to amicably settle the Dispute in accordance with Clause 6.2.1 within the period specified therein, any of the Parties shall be entitled to within thirty (30) days after expiry of the aforesaid period, refer the Dispute to the Company Secretary of REC PDCL and Chief Executive/ Managing Director of the Selected Bidder for resolution of the said Dispute. The attempt to bring about such resolution shall be considered to have failed if not resolved within thirty (30) days from the date of receipt of a written notification in this regard.
- 6.2.3 In the event the Dispute is not settled in accordance with Clause 6.2.2 above, any Party to the Dispute shall be entitled to serve a notice invoking this Clause and making a reference to a sole arbitrator. If the Parties to the Dispute cannot agree as to the appointment of the sole arbitrator within thirty (30) days of receipt of the notice of the Party making the reference, then the Shares Seller along with the Company shall appoint one arbitrator and the Selected Bidder shall appoint one arbitrator and the two arbitrators, so appointed shall appoint a third arbitrator. However, after the Closing Date, in such an event the Shares Seller shall appoint one arbitrator and the Selected Bidder along with the Company shall appoint one arbitrator and the two arbitrators, so appointed shall appoint the third arbitrator.
- 6.2.4 The place of the arbitration shall be New Delhi. The Arbitration proceedings shall be governed by the Arbitration and Conciliation Act, 1996.

6.2.5 The proceedings of arbitration shall be in English language.

6.2.6 The arbitrator's award shall be substantiated in writing. The arbitrators shall also decide on the costs of the arbitration proceedings. In case the arbitrators have not decided on the costs of the arbitration proceedings, each Party to the Dispute shall bear its own costs, in relation to the arbitration proceedings.

6.3 AUTHORISED PERSON

For the purposes of this Agreement, the Selected Bidder is represented by _____ [Insert Name of the authorized representative of the Selected Bidder/ Lead Member, in case of Consortium], pursuant to an authorization granted to _____ [Insert Name of the authorized representative of the Selected Bidder/Lead Member, in case of Consortium] through necessary Board resolutions. Further, _____ [Insert Name of the authorized representative of the Selected Bidder/Lead Member, in case of Consortium] is also authorized by such resolutions to take any decision which may be required to be taken, do all acts and execute all documents which are or may be required by the Selected Bidder for the proper and effective fulfillment of the rights and obligations under this Agreement. Any action taken or document executed by _____ [Insert Name of the authorized representative of the Selected Bidder/Lead Member, in case of Consortium] shall be deemed to be acts done or documents executed by the Selected Bidder and shall be binding on the Selected Bidder.

6.4 RESERVATION OF RIGHTS

No forbearance, indulgence or relaxation or inaction by any Party at any time to require performance of any of the provisions of this Agreement shall in any way affect, diminish or prejudice the right of such Party to require performance of that provision, and any waiver or acquiescence by any Party of any breach of any of the provisions of this Agreement shall not be construed as a waiver or acquiescence of any continuing or succeeding breach of such provisions, a waiver of any right under or arising out of this Agreement or acquiescence to or recognition of rights other than that expressly stipulated in this Agreement.

6.5 CUMULATIVE RIGHTS

All remedies of either Party under this Agreement whether provided herein or conferred by statute, civil law, common law, custom or trade usage, are cumulative and not alternative and may be enforced successively or concurrently.

6.6 PARTIAL INVALIDITY

If any provision of this Agreement or the application thereof to any person or circumstance shall be invalid or unenforceable to any extent, the remainder of this Agreement and the application of such provision to persons or circumstances other than those as to which it is held invalid or unenforceable shall not be affected thereby, and each provision of this Agreement shall be valid and enforceable to the fullest extent permitted by law. Any invalid or unenforceable provision of this Agreement shall be replaced with a provision, which is valid and enforceable and most nearly reflects the original intent of the unenforceable provision.

6.7 TERMINATION

If (i) the Closing does not occur on the Closing Date for any reason whatsoever, or (ii) the Letter of Intent is withdrawn or terminated for any reason, or (iii) due to termination of the TSA by the Central Transmission Utility of India Limited (CTUIL) in accordance with Article 3.3.2 or Article 13 of the TSA thereof, REC PDCL shall have a right to terminate this Agreement forthwith by giving a written notice to the other Parties hereto.

6.8 AMENDMENTS

No modification or amendment of this Agreement and no waiver of any of the terms or conditions hereof shall be valid or binding unless made in writing and duly executed by all the Parties.

6.9 ASSIGNMENT

This Agreement and the rights and liabilities hereunder shall bind and inure to the benefit of the respective successors of the Parties hereto, but no Party hereto shall assign or transfer its rights and liabilities hereunder to any other Person without the prior written consent of the other Parties, which will not be unreasonably withheld.

6.10 ENTIRE AGREEMENT

This Agreement constitutes the entire Agreement between the Parties with respect to the subject matter herein and supersedes and cancels any prior oral or written agreement, representation, understanding, arrangement, communication or expression of intent relating to the subject matter of this Agreement.

6.11 COSTS

Each of the Parties hereto shall pay their own costs and expenses relating to the negotiation, preparation and execution of this Agreement and the transactions contemplated by this Agreement.

The Selected Bidder shall be liable to bear and pay the costs in respect of this Agreement and transfer of Sale Shares.

6.12 RELATIONSHIP

None of the provisions of this Agreement shall be deemed to constitute a partnership between the Parties hereto and no Party shall have any authority to bind the other Party otherwise than under this Agreement or shall be deemed to be the agent of the other in any way.

6.13 GOVERNING LAW AND JURISDICTION

This Agreement shall be governed by and construed in accordance with the laws of India and shall be subject to the exclusive jurisdiction of the courts of Delhi.

6.14 COUNTERPARTS

This Agreement may be executed in counterparts by the Parties and each fully executed counterpart shall be deemed to be original.

6.15 CONFIDENTIALITY

The Parties undertake to hold in confidence and not to disclose the terms and conditions of the transaction contemplated hereby to third parties, except:

- (a) to their professional advisors;
- (b) to their officers, employees, agents or representatives, who need to have access to such information for the proper performance of their activities;
- (c) disclosures required under Law;

without the prior written consent of the other Parties.

Provided that the Central Transmission Utility of India Limited (CTUIL) and REC PDCL may at any time, disclose the terms and conditions of transactions contemplated hereby to any person, to the extent stipulated under the law or the Bidding Guidelines.

6.16 INDEMNIFICATION

The Parties hereby agree that transfer of Sale Shares to the Selected Bidder shall vest all the rights, privileges, licenses, responsibilities, liabilities and other obligations pertaining to the Company in the Selected Bidder.

- The Selected Bidder hereby agrees that the Selected Bidder shall not be entitled to any claims or initiate any legal proceedings by itself or through the Transmission Service Provider against the Share Sellers, its directors, officers, employees and the subscribers including the members of any committees appointed by them in respect of any actions or decisions taken by any of them up to the Closing Date in furtherance of the Project referred to in recital A of this Agreement.
- Further, the Selected Bidder hereby indemnifies and holds harmless at all times the Share Seller against all past, present and future third party claims and liabilities arising out of actions or decisions taken by any of the persons or bodies referred to in Clause 6.3 up to the Closing Date in furtherance of the Project referred to above or otherwise concerning the Company. All such actions shall be defended by the Selected Bidder either itself or through the TSP at its own cost.
- The Parties hereby agree that the provisions of this clause shall survive the termination of this Agreement.

6.17 SURVIVAL

The provisions of Clause 1 (Definitions and Interpretation), Clause 4 (Representations and Warranties), Clause 6.2 (Dispute Resolution), Clause 6.7 (Termination), Clause 6.15 (Confidentiality), Clause 6.16 (Indemnification) and other representations, warranties, covenants and provisions contained herein that by their nature are intended to survive, shall survive the termination of this Agreement

6.18 FORCE MAJEURE

No party shall be liable for its inability or delay in performing any of its obligations hereunder if such delay is caused by circumstances beyond the reasonable control of the party including delay caused through flood, riot, Act of God, lightning civil commotion, storm, tempest and earthquake.

IN WITNESS WHEREOF, THE PARTIES HERETO HAVE CAUSED THIS AGREEMENT TO BE DULY EXECUTED AND DELIVERED AS OF THE DAY AND YEAR FIRST ABOVE WRITTEN

SIGNED AND DELIVERED by The within named **REC Power Development and Consultancy Limited** by the hand of Sh. _____ authorised pursuant to the resolution passed by its board of directors in its meeting held on _____

IN THE PRESENCE OF:

WITNESS: 1. _____ 2. _____
(name and address)

SIGNED AND DELIVERED by The within named **{Insert Name of the SPV}** by the hand

of Sh. _____, its Chairman, authorised pursuant to the resolution passed by its board of directors in its meeting held on _____

IN THE PRESENCE OF

WITNESS: 1. _____ 2. _____
(name and address)

SIGNED AND DELIVERED by The within named [insert name of the selected bidder] by the hand of Sh.

_____, its _____, authorised pursuant to the resolution passed by its board of directors in its meeting held on _____

IN THE PRESENCE OF:

WITNESS:
(Name and Address)

ANNEXURE A**DESCRIPTION OF THE SALE SHARES**

S. NO.	NAME OF THE SHAREHOLDER	NUMBER OF EQUITY SHARES HELD	PERCENTAGE OF THE TOTAL PAID UP EQUITY CAPITAL
1.	REC Power Development and Consultancy Limited through its _____	49,994	99.988
2.		1	0.002
3.		1	0.002
4.		1	0.002
5.		1	0.002
6.		1	0.002
7.		1	0.002
	Total	50,000	100.000

*Held as nominee of RECPDCL

TAX INVOICE

(ORIGINAL FOR RECEIPT) **293** eInvoice

ANNEXURE P/7

IRN : 77189d78d426001a0e72d4e35ba0042e193759b-
24b2c31595336ea7aee367893
Ack No. : 132316419154893
Ack Date : 31-Oct-23

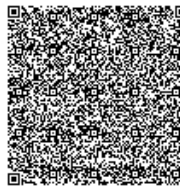

REC Power Development & Consultancy Limited (Formerly REC Power Distribution Company Limited) Ground Floor, I-4, RECPDCL REC World Headquarter, Block-D, Sector-29, Gurgaon GSTIN/UIN: 06AADCR7399K1ZP State Name : Haryana, Code : 06 CIN: U40101DL2007GOI165779 E-Mail : fin.delhi@recpdcl.in	Invoice No. HRY/127/23-24	Dated 30-Oct-23
	Reference No. & Date.	Other References
	Buyer's Order No.	Dated
Buyer (Bill to) IndiGrid 2 Limited Unit No 101, First Floor, Windsor Villeage, Kolekalyan Off CST Road, Vidyanagri Marg, Santacruz(East), Mumbai GSTIN/UIN : 27AAVCS2921A1ZD State Name : Maharashtra, Code : 27 Place of Supply : Maharashtra		

Sl No.	Particulars	HSN/SAC	Rate	per	Amount
1	Income From RFP documents IGST OUTPUT TAX -Haryana	998431		18 %	5,00,000.00 90,000.00
Total					₹ 5,90,000.00

Declaration

We declare that this invoice shows the actual price of the services described and that all particulars are true and correct.

Amount Chargeable (in words)

INR Five Lakh Ninety Thousand Only

Remarks:

Being invoice raised to M/s. Indigrid-2 towards RPF
Fee against Kallam Transco Ltd.

Company's PAN : **AADCR7399K**

(Scan for Payment)

Company's Bank Details

Bank Name : **IDFC First Bank**
A/c No. : **10000697415**
Branch & IFS Code : **Bahadur shah Zafar Marg, New Delhi & IDFB0020101**

(Scan for Payment)

Company's Bank Details

Bank Name : **IDFC First Bank**
A/c No. : **10000697415**
Branch & IFS Code : **Bahadur shah Zafar Marg, New Delhi & IDFB0020101**



for REC Power Development & Consultancy Limited

Authorised Signatory

SUBJECT TO DELHI JURISDICTION

This is a Computer Generated Invoice

294 ANNEXURE P/8

Wasim Alam

From: Rupesh Singh <Rupesh.Singh@recpdcl.in>
Sent: 27 October 2023 17:50
To: Wasim Alam
Cc: P S Hariharan; Anil Kumar Yadav; AMIT CHATTERJEE; TCB Projects
Subject: RECPDCL: Issuance of Survey Report for "Western Region Network Expansion scheme in Kallam area of Maharashtra".
Attachments: Final Kallam Survey report.pdf

[Mail from External Sender - be careful with Links, Attachments and Responses.](#)

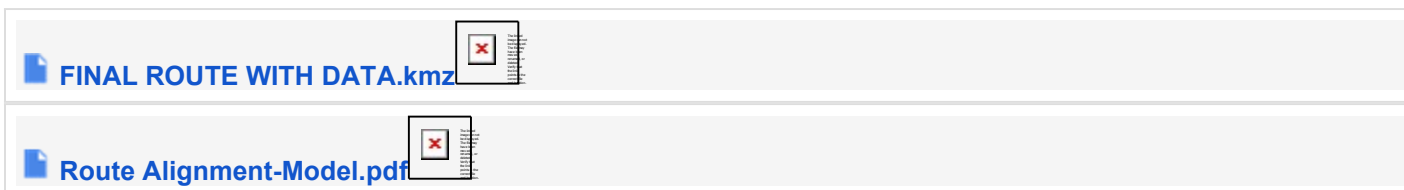

Dear Sir/ Madam,

This has reference to the RFP dated 13.10.2023 for the selection of Transmission Service Provider to establish Transmission System for "Western Region Network Expansion scheme in Kallam area of Maharashtra" (hereinafter referred to as "the Project") through tariff based competitive bidding process.

In this regard, please find attached Survey Report, TOPO sheet and KMZ file for the subject cited project.

Thanks & Regards,

Rupesh Singh (is"k flag)

REC Power Development and Consultancy Limited

(A wholly owned subsidiary of REC Ltd., a 'Maharatna CPSE' under Ministry of Power, GoI)

REC World Headquarter, C Block, Plot No. 1-4,

Sector-29, Gurugram, Haryana-122 001



::DISCLAIMER::

The contents of this e-mail and any attachment(s) with it are confidential and intended for the sole use of named recipients and may contain legally confidential and / or privileged information. It shall not attach any liability on the originator. Any views or opinions presented in this email are solely those of the author and may not necessarily reflect the opinions of RECPDCL or its subsidiaries. If the reader of this message is not the intended recipient, immediately inform the originator by reply e-mail and delete this mail will all content and attachment(s) . Any unauthorized reproduction, dissemination, copying, disclosure, modification, distribution and / or publication of this e-mail and attachment is strictly prohibited and may be unlawful. Before opening any mail and attachments please check them for viruses and defect. Email communications are not secure and capable of interception corruption and delays. Anyone communicating with the originator or RECPDCL or its subsidiaries by email accept the risk of email communication and their consequences.

We Believe in.. Delivering Beyond Expectations!

Disclaimer: *The contents of this e-mail and any attachment(s) with it are confidential and intended for the sole use of named recipients and may contain legally confidential and / or privileged information. It shall not attach any liability on the originator. Any views or opinions presented in this email are solely those of the author and may not necessarily reflect the opinions of RECPDCL. If the reader of this message is not the intended recipient, immediately inform the originator by reply e-mail and delete this mail with all content and attachment(s). Any unauthorized reproduction, dissemination, copying, disclosure, modification, distribution and / or publication of this e-mail and attachment is strictly prohibited and may be unlawful. Before opening any mail and attachments please check them for viruses and defect. Email communications are not secure and capable of interception corruption and delays. Anyone communicating with the originator or RECPDCL by email accept the risk of email communication and their consequences.*

296

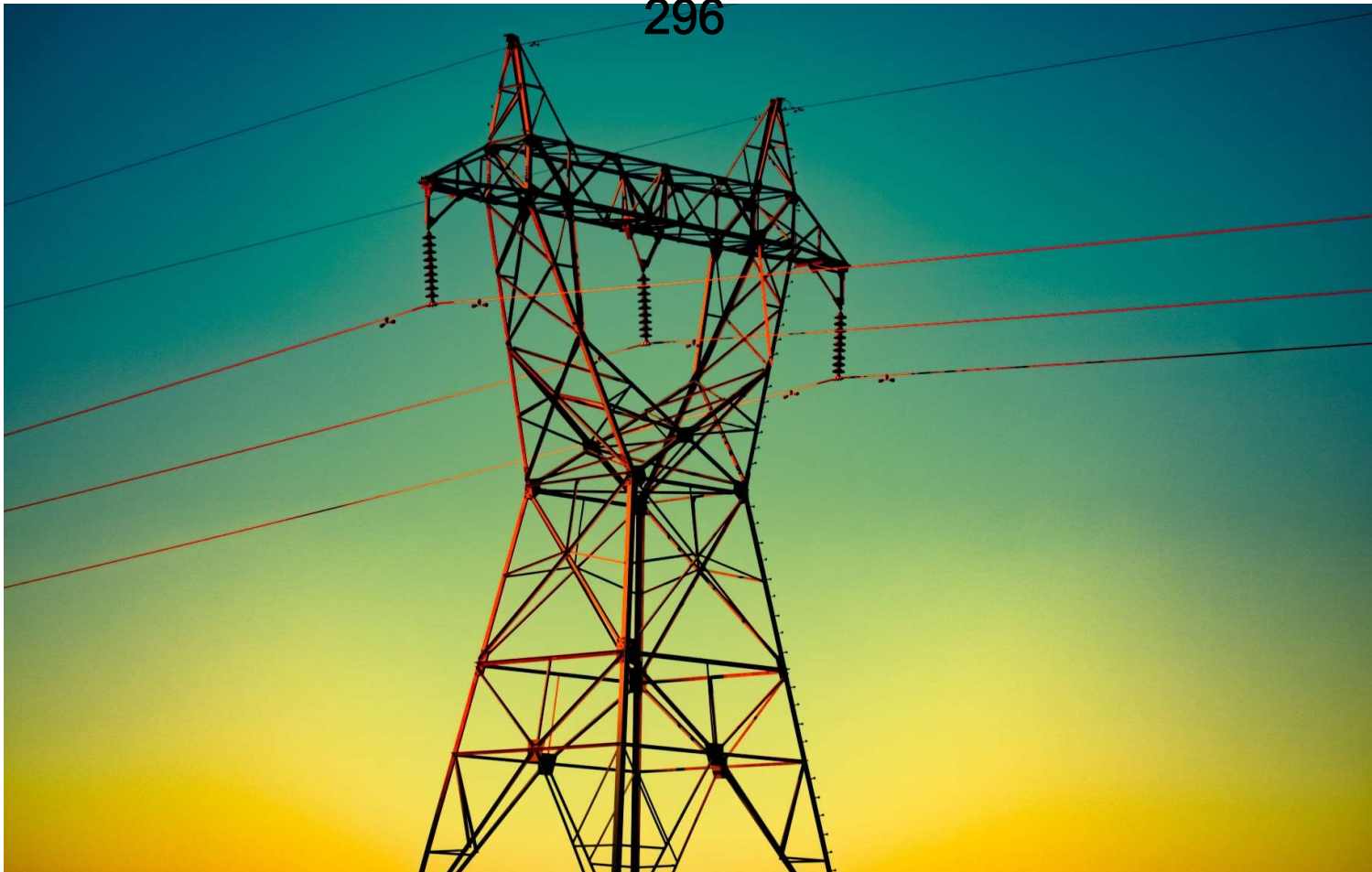

SURVEY REPORT & RA DRAWINGS

For

Western Region Network Expansion Scheme in
Kallam area of Maharashtra



REC Power Development and Consultancy Limited
D- Block, REC Corporate Headquarter,
Plot No. I-4, Sector-29, Gurugram-122001
Regd. Office: Core 4, Scope Complex, 7,
Lodhi Road, New Delhi - 110003
Website: www.recpdcl.in

DISCLAIMER

Bidders may please note that the Bid Process Coordinator (BPC) has carried out a survey of the Transmission System associated with the Project. While every possible care has been taken in identifying the involvement of forest area / animal & bird sanctuary/ mines in the proposed routes. However, Bidders in their own interest should carry out required surveys and field investigation for submission of their Bid. For the purpose of carrying out required survey, the address and co-ordinate of each location of sub-station has been provided by the BPC. The coordinate of location of the sub-station is only for the purpose of facilitating Bidders to locate the sub-station and the same should not be considered as the point of termination of transmission line. For exact point of termination of transmission line, the Bidder shall have to coordinate with the agency responsible for construction of sub-station / switchyard who shall provide the inter-connection facility. Bidders in their own interest should visit the project site to confirm the location of sub-stations and any apprehension in this regard should be brought to the notice of the BPC.

Failure to verify the location of sub-station, investigate the route of the Transmission Lines associated with the Project and to examine, inspect site or subsurface conditions fully shall not be grounds for a Bidder to alter its Bid after the Bid Deadline nor shall it relieve a Bidder from any responsibility for appropriately eliminating the difficulty or costs of successfully completing the Project.

The BPC, its authorized representative, any of the Long Term Transmission Customer(s), nor their directors, employees or advisors/consultants make any representation or warranty, express or implied, or accept any responsibility or liability, whatsoever, in respect of any statements or omissions made in the Survey Report, or the accuracy, completeness or reliability of information contained therein, and shall incur no liability under any law, statute, rules or regulations as to the accuracy, reliability or completeness of such survey report, even if any loss or damage is caused to the Bidders by any act or omission on their part.

TABLE OF CONTENT

Sr. No.	Description
1.	Introduction
2.	Scope of Work
3.	Approach & Methodology
4.	Geographical Information
SECTION: 1	
1.0	LILo of both Circuits of Parli (M) – Karjat (M) / Lonikand-II(M) 400 Kv D/c Line (twin moose) at Kallam PS
1.1	Coordinates of Both End
1.2	Index Map of SOI Topo sheet
1.3	Coordinates of Three Alternate Route
1.4	Summary of Proposed Route
1.5	Wind Zone Map
1.6	Result & Conclusions
1.7	Route Alignment Map on Digitized Topo sheet

CHAPTER-1

INTRODUCTION

1.0 INTRODUCTION

Development of any country especially of any developing country depends solely on its power generation and proper distribution. The demand of power supply in proper way increases rapidly due to industrial demand and development of the area as a whole. India is developing fast and the demand - supply ratio of power distribution is unable to keep pace with the rapid industrial growth. Due to heavy urbanization and industrial demand the impact on power distribution has become an essential necessity of the day. Power generation, transmission and distribution is a long-drawn process, which is being carried out essential by both the Govt.& Private sector organization.

In order to execute such magnitude of transmission system, which is of much higher order than those totally implemented in last 5 decades, precise planning, costing, scheduling etc, would be required. Optimum deployment of resources also would be of prime targets in implementing this transmission system. As transmission line have to traverse the length and breadth of country, for evacuation of power from generating stations to load centers and beneficiary states, the topographical & geographical nature of the terrains play significant influence in the project's cost and implementation time.

Hence, it is essential that at the planning stage itself that various alternative routes and technical solution for transmission line be examined in detail. For undertaking such studies, one of the major requirements is obtaining adequate information regarding the site location and identifies, subsequently, during implementation of the projects, it is required to obtain elaborate details about terrain, soil condition, constraints etc. of the route for proper resources planning, costing etc.as well as reducing the implementation time.

Presently, conventional methods of survey like walk over survey, preliminary survey and detailed survey are carried out at various stages from conceptualization of the projects to implementation, which are time consuming task. Presently, there are new means available to conduct survey using remote sensing, PS based survey etc.

M/s. Pratik Surveyors (India) Pvt. Ltd. has been awarded by M/s REC Power Development and Consultancy Limited to study and execute the Preliminary survey of three feasible routes, taking all logistic precaution and use most modern survey Techniques to survey the feasible routes and suggest the logically viable routes to erect the power line for distribution of power system.

CHAPTER-2

SCOPE OF WORK

2.0 SCOPE OF WORK

1.	LILO of both Circuits of Parli (M) – Karjat (M) / Lonikand-II(M) 400 Kv D/c Line (twin moose) at Kallam PS.
----	---

2.1 Identification of Tentative Routes:

The route sighting and selection process began with an inventory of existing and planned land use. Three alternative route corridors were identified largely by maximizing linear sighting opportunities, such as following existing roadways and power line corridors, negotiation with river, railway, road, electric power line and telephone line crossings and least crossing of notified forest area. All efforts have been made to provide minimum numbers of angle points and almost care have been taken to select the possible places for all angle points. The angle points have been fixed up on the ground with minimum possible angle of deviation. Rivers are mainly crossed with right angles and a minimum span. Crossings are located on high bank and are out of the maximum flood level. Similarly, power line crossings have been fixed as close as possible to the right angle but not less than the 60-deg. crossing.

2.2 Selection Criteria for Transmission Line Route

- The alignment of the transmission line should be most economical from the point of view of construction and maintenance.
- The alignment of the transmission line selected should be the shortest possible one.
- Routing of transmission line through protected/reserved forest area should be avoided. In case it is not possible to avoid the forests or areas having large trees completely, and then keeping in view of the overall economy, the route should be aligned in such a way that cutting of trees is minimums.
- The route should have minimum crossings of Major rivers, Railway lines, National/State highways, overhead EHV power line and communication lines.
- The number of angle points shall be kept to a minimum.
- Marshy and low laying areas, river beds and earth slip zones shall be avoided to Minimize risk to the foundations.
- It would be preferable to utilize level ground for the alignment.
- Crossing of power lines shall be minimums. Alignment will be kept at a minimum distance of 300 m from power lines to avoid induction problems on the lower voltage lines.

- Crossing of communication line shall be minimized and it shall be preferably at right angle. Proximity and parallelism with telecom lines shall be eliminated to avoid danger of induction to them.
- Areas subjected to flooding such as nala shall be avoided.
- Restricted areas such as civil and military airfield shall be avoided. Care shall also be taken to avoid aircraft landing approaches.
- All alignment should be easily accessible both in dry and rainy seasons to enable maintenance throughout the year.
- Certain areas such as quarry sites, tea, tobacco and saffron fields and rich plantations, gardens & nurseries which will present the Owner problems in acquisition of right of way and way leave clearance during construction and maintenance should be avoided.
- Angle points should be selected such that shifting of the point within 100 m radius is possible at the time of construction of the line.
- The line routing should avoid large habitations, densely populated areas, Forest, Animal/Bird sanctuary, reserve coal belt areas, oil pipe line/underground inflammable pipe lines etc. to the extent possible.
- The areas requiring special foundations and those prone to flooding should be avoided.

CHAPTER-3

APPROACH & METHODOLOGY

3.0 METHODOLOGY

Projection

We are using Google Image for Showing Final route which we will be taken in walkover survey in following projection:

- Projection : UTM
- Spheroid : WGS84
- Datum : WGS84
- North or South : South
- Zone : 43

Data Collection

We are using GPS for Walkover survey. In walkover survey we are taking major constraints like:

- City and village sprawl
- Contours
- Spot Heights and Bench Marks
- Railway lines (MG/BG)
- Metalled Roads (National/State Highways),
- Major Rivers
- Canals
- Nallah/Drain crossings
- Forest (Reserved/Protected/Open Scrub)
- Protected areas (Cantonments, Air fields)
- Main power lines (EHV) and other electrical power lines
- Telephone lines
- Angle points
- Lakes, Reservoirs and Ponds
- Air Strip/Airport

Data Quality

- **Mapping standards:** Standard mapping standards are followed for compliances of data at State and National level. Map projection is followed as per specifications mentioned in tender.
- **Dimensional accuracy:** Minimum map able unit was defined based on the scale of the map. Standard guidelines are followed for vertical and horizontal level accuracy and separately for both the scale mapping.
- **GIS database standard:** Industrial GIS standard along with the SOI standards are followed while preparing the GIS database.

- **Quality Control during Data Preparation:** The data has undergone stringent quality checks before final shipment to ensure best possible quality output is delivered. Some of the examples of the tasks to be carried out during Quality Check are mentioned below:

CHAPTER-4

GEOGRAPHICAL INFORMATION

4.0 GEOGRAPHICAL INFORMATION

4.1 Climate of Madhya Pradesh

Maharashtra has a subtropical climate with three distinct seasons: winter (December to February), summer (March to May) and the rainy season (June to October). In winter, the mean minimum temperature is 29°C, though it can drop as low as 3°C and rise to a mean maximum temperature of 22°C. The whole area of Kallam is fall under the Wind zone 2.

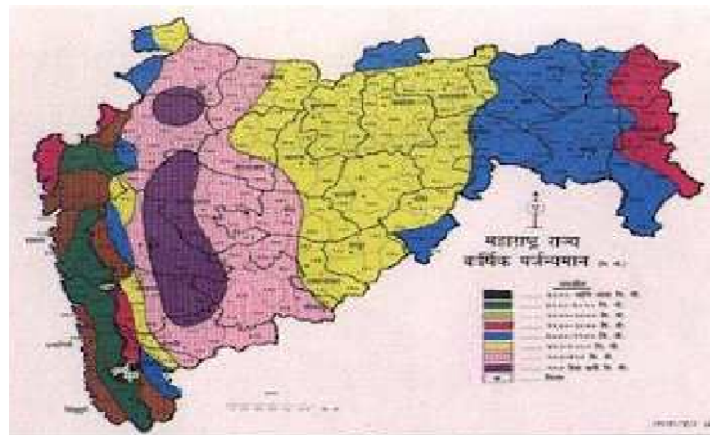

4.2 Weather & Humidity

Maharashtra experiences severe atrocities of the summer season. As the state falls in the Central Region of India and is located at a considerable distance from the sea, summers here are very extreme. The temperature starts ascending from the month of March. In this season, the mercury level soars to severe heights. In fact, May is probably the hottest month of the year in the state. Weather remains extremely hot and humid. The mean maximum temperature rises to around 42.5°C in the northern region. However, in most of the places, the mean maximum temperature remains around 35°C to 39°C. The average humidity of Kallam is varies from 85% to 98%.

4.3 Maximum Altitude & Terrain

The maximum altitude from sea level is 628 meter of Kallam(Kalamb) Village. It has mostly plain land.

4.4 Rainfall

With the onset of June, the temperature slowly declines. Clouds envelop the sky, fed by the Arabian Sea and the Bay of Bengal, and bring a lot of changes to the climatic conditions of the state. Monsoon begins towards the end of June and lasts till September. The place experiences frequent spells of rain that enlivens the whip-lashed land of the summer. Maximum downpour happens between the months of June and September, with a little rainfall during December and January, due to the low pressure build up in the atmosphere. The average rainfall however varies from region to region. Annual rainfall in the state varies from 600 to 1600 mm. The average rainfall for the state is 1200 mm. There is one distinct rainy season when the state receives rains through the southwest monsoon, in the months of June to October and the average numbers of rainy days are 54.

4.5 Agriculture

Maharashtra's primary food crops are mangoes, grapes, bananas, oranges, wheat, rice, jawar, bajra, and pulses. Groundnut, Cotton, sugarcane, turmeric, and tobacco are cash crops. The state has tropical weather, with the Konkan and the mountainous Sahyadri region receiving most of the state's rainfall.

In recent years, Maharashtra has surpassed other states as the top producer of pomegranates, Alphonso mangoes (90%), and seedless grapes (78%), as well as onions (63%), bananas (75%), mandarin oranges (75%), tomatoes (42%), and onions. Due to its approximately 150 productive cooperative sugar mills, the state dominates the sugar industry sector.

The Gross Cropped Area in Maharashtra is 225.56 lakh ha and the Net Cropped Area is 174.73 lakh ha.

Cultivable waste, current fallow and other fallow land is 11% of the geographical area of the State. Gross Irrigated area is 44.19 lakh ha and 80% of the area is rain fed. Small and marginal farmers holdings are 90 lakh which is 70% of the total holdings. The state has a large area under alkaline soil and saline soil which is 4.23 lakh ha and 1.84 lakh ha respectively. More than 50% soil is deficient in zinc.

4.6 Soil Type

Soils of Maharashtra More than 90% of Maharashtra is made up of basalt rock which is made up of igneous rock. As a result, black soil formed from basalt rock is found in large quantities in Maharashtra. But at the same time, different types of soil are also found in Maharashtra.

- Black Soil
- Laterite Soil
- Alluvial Soil
- Red Soil
- Marshy and Peaty Soil

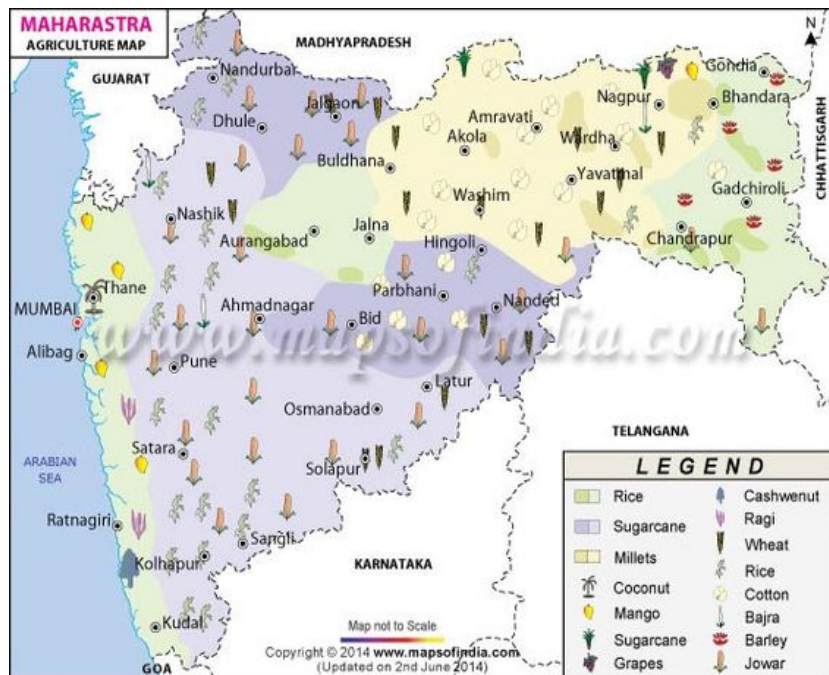

SECTION:1
CHAPTER-1.0

LILO of both Circuits of Parli (M) – Karjat (M) / Lonikand-II(M) 400 Kv D/c Line (twin moose) at Kallam PS

CHAPTER-1.1

COORDINATES OF BOTH END

Coordinates Details

1. Existing KTL 400/220KV Kallam Substation.*	Coordinate	
	UTM	Latitude-Longitude
Village: Selu Tehsil: Kallam District: Osmanabad State: Maharashtra	592049 E 2059338 N	18°37'22.80" N 75°52'21.37" E

* The exact coordinate of the construction of 400 kV line bays at Kallam PS for termination of LILO of both Circuits of Parli (M) – Karjat (M) / Lonikand-II(M) 400 Kv D/c Line to be obtained from substation owner during execution stage.

2. Tapping point of LILO of both Circuits of Parli (M) – Karjat (M) / Lonikand-II(M) 400 Kv D/c Line (twin moose) at Kallam PS *	Coordinate	
	UTM	Latitude-Longitude
EXI.LOC.NO-157 Village: Selu Tehsil: Kallam District: Osmanabad State: Maharashtra	601342 E 2053591 N	25°43 '47.71" N 78°20 '28.32" E
EXI.LOC.NO-159 Village: Hawargaon Tehsil: Kallam District: Osmanabad State: Maharashtra	600816 E 2052991 N	18°33'54.86" N 75°57'19.36" E

* The successful Bidder/TSP (Transmission Service Provider) shall finalize the point of termination i.e. the tapping tower in coordination with existing transmission line owner during execution stage.

CHAPTER-1.2

INDEX MAP SOI TOPOSHEETS

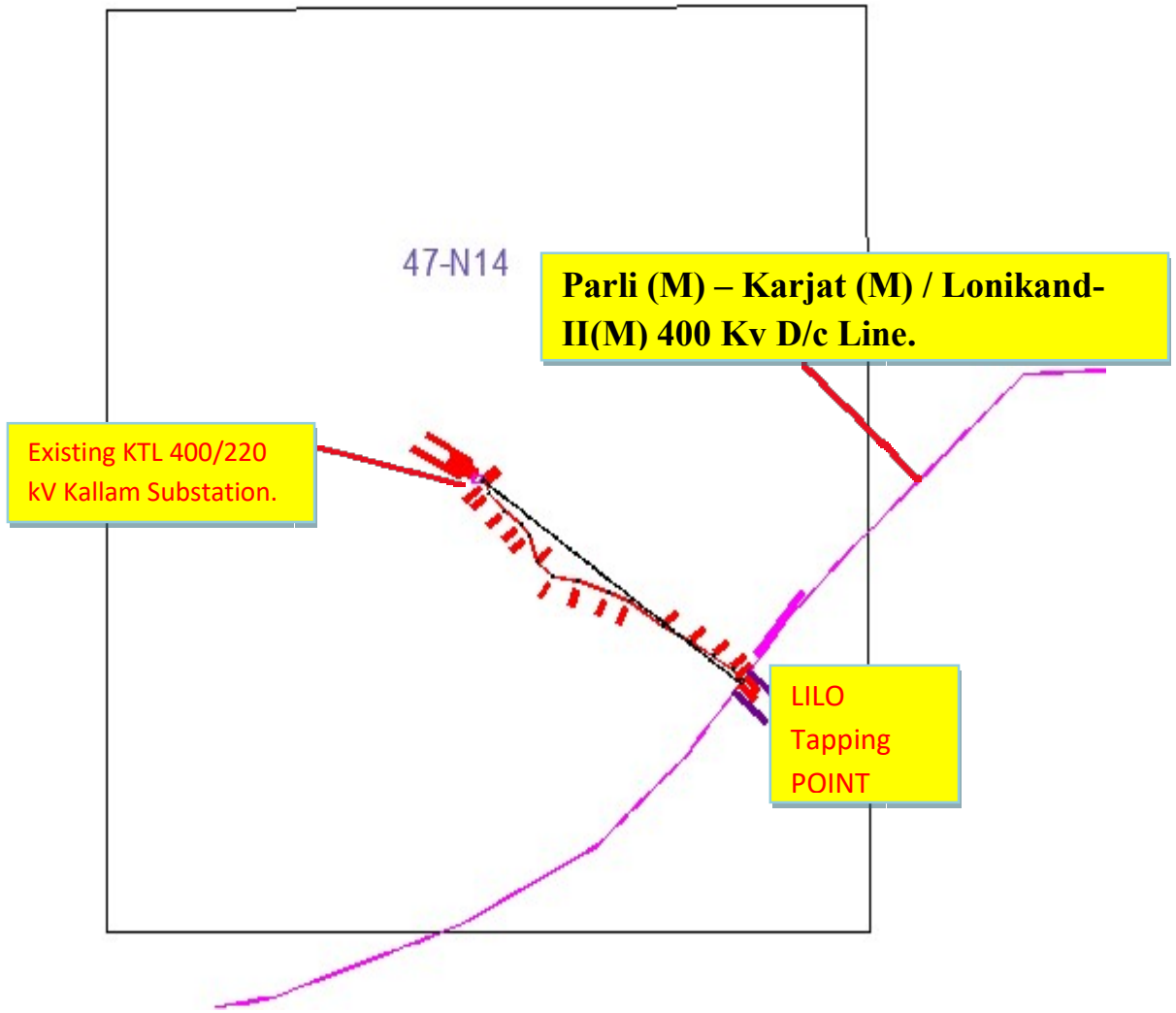

CHAPTER-1.3

COORDINATES OF PROPOSED ROUTE

LILO of both Circuits of Parli (M) – Karjat (M) / Lonikand-II(M) 400 Kv D/c Line (twin moose) at Kallam PS								
AP NO.	Easting	Northing	Latitude	Longitude	Sc. Length (m)	Cum. Length (m)	Angle of Deviation	Crossing Details
GANTRY	592049	2059338	18°37'22.80"N	75°52'21.37"E			00°00'00.0"	Existing Kallam Substation
					84.17			
AP-001	592126	2059304	18°37'21.68"N	75°52'23.99"E		84.17	28°2'44.6"RT	D/C TOWER
					118.23			
AP-002	592199	2059211	18°37'18.65"N	75°52'26.46"E		202.4	15°25'12.0"ER	M/C TOWER START
					0			
GANTRY	592046	2059320	18°37'22.22"N	75°52'21.26"		202.4	00°00'00.0"	Proposed Substation
					75.18			
AP-001A	592112	2059284	18°37'21.04"N	75°52'23.51"E		277.58	11°23'20.0"RT	D/C TOWER
					113.57			
AP-002	592199	2059211	18°37'18.65"N	75°52'26.46"E		391.15	27°17'26.3"RT	M/C TOWER START
					335.89			
AP-003	592329	2058901	18°37'8.55"N	75°52'30.84"E		727.04	23°35'53.3"LT	
					748.65			
AP-004	592870	2058384	18°36'51.63"N	75°52'49.22"E		1475.69	7°23'19.4"LT	
					687.43			
AP-005	593424	2057977	18°36'38.30"N	75°53'8.06"E		2163.12	10°39'29.8"RT	
					413.19			
AP-006	593706	2057675	18°36'28.44"N	75°53'17.63"E		2576.31	23°13'0.7"RT	
					849.32			
AP-007	593994	2056876	18°36'2.39"N	75°53'27.32"		3425.63	30°27'17.2"LT	
					715.09			
AP-008	594544	2056419	18°35'47.44"N	75°53'46.01"E		4140.72	31°44'55.6"LT	

LILO of both Circuits of Parli (M) – Karjat (M) / Lonikand-II(M) 400 Kv D/c Line (twin moose) at Kallam PS								
AP NO.	Easting	Northing	Latitude	Longitude	Sc. Length (m)	Cum. Length (m)	Angle of Deviation	Crossing Details
					886.57			
AP-009	595422	2056296	18°35'43.29"N	75°54'15.94"E		5027.29	9°12'7.5"RT	
					1080.18			
AP-010	596454	2055977	18°35'32.74"N	75°54'51.10"E		6107.47	3°4'23.3"RT	
					788.75			
AP-011	597194	2055704	18°35'23.74"N	75°55'16.30"E		6896.22	13°12'45.0"RT	
					1396.47			
AP-012	598359	2054934	18°34'58.49"N	75°55'55.91"E		8292.69	8°0'47.2"LT	
					1056.52			
AP-013	599313	2054480	18°34'43.56"N	75°56'28.37"E		9349.21	2°33'44.1"RT	
					885.77			
AP-014	600095	2054064	18°34'29.90"N	75°56'54.98"E		10234.98	2°10'52.2"RT	
					777.47			
AP-015	600767	2053673	18°34'17.06"N	75°57'17.83"E		11012.45	20°53'2.0"RT	
					407.46			
AP-016	601023	2053356	18°34'6.70"N	75°57'26.51"E		11419.91	57°38'56.3"LT	M/C TOWER END
					126.57			
AP-017	601149	2053371	18°34'7.15"N	75°57'30.80"E		11546.48	42°13'0.4"LT	D/C TOWER
					293.3			
EXI.LOC.NO-157	601342	2053591	25°43 '47.71"N	78°20 '28.32"E		11839.78	00°00'00.0"	LILO Tapping POINT
					0			
AP-016	601023	2053356	18°34'6.70"N	75°57'26.51"E		11839.78	30°43'15.5"RT	
					111.87			
AP-017A	601039	2053245	18°34'3.10"N	75°57'27.03"E		11951.65	49°28'58.3"RT	D/C TOWER

LILO of both Circuits of Parli (M) – Karjat (M) / Lonikand-II(M) 400 Kv D/c Line (twin moose) at Kallam PS								
AP NO.	Easting	Northing	Latitude	Longitude	Sc. Length (m)	Cum. Length (m)	Angle of Deviation	Crossing Details
					338.58			
EXI.LOC.NO-159	600816	2052991	18°33'54.86"N	75°57'19.36"E		12290.23	00°00'00.0"	LILO Tapping POINT

CHAPTER-1.4

SUMMARY OF PROPOSED ROUTE

Summary of the Proposed Route		
Sl.No.	Description	Proposed Route
1	Bee Line Length	10.86 Kms.
	Line Length	12.290 Kms.
	a) Plain	95%
	b) Undulated terrain	5%
2	Angle Point	19
3	Place of Archaeological Importance	Nil
4	Coastal Regulation Zone(CRZ)	Nil
5	Shooting Range /Firing Range	Nil
6	Coal/ Mineral Mining Areas	Nil
7	Lakes / Reservoirs	Nil
8	Place of Historical/ Cultural/ Religious/Tourist	Nil
9	Defence Installation/ Vicinity to Civil and Airports/Seaport	Nil
10	Social issue / R & R Measure	Nil
11	Pollution Level /Section wise as per available pollution Map	Good (AQI: 0-50)
12	Oil pipe line/ under Ground inflammable pipe lines	Nil
13	Forest (Approx.)	Nil
	a) Reserved Forest	Nil
	b) Protected Forest	Nil
	c) Open Scrub	Along the Route
14	Wildlife infringement	Nil
15	Animal/Bird sanctuary	Nil
16	Infringement of endangered species habitat	Nil
17	National Park	Nil
18	GIB area (Priority/Potential area)	Nil
19	Creek, Marshy and low-laying area	Nil
20	No. of Pile/Special Foundation	Nil
21	Transportation & Maintenance	Available
22	Power Line crossings (110kv & Above)	Nil.
23	Telecom Line Crossing	Nil
24	Railway Crossing	Nil
25	Airport / Air Strip	Nil
26	River – Nadi	Nil
	a) Major	-
	b) Minor (Nadi)	-
27	NH Crossing	Nil
28	SH Crossing	Nil
29	Circle rate of land (Hectare)	Approx. from Rs. 3 lakh – Rs. 10 lakhs

30	Market rate of land (Hectare)	Approx. from Rs. 20 lakh – Rs. 25 lakhs
31	Cost of crop and Tree compensation	As par Compensation Guideline issued by the respective State Government and Forest Department
32	Land Availability (if required for acquisition)	Yes
	Extent of land available	Yes
	Land used pattern (agricultural, barren, forest etc.)	Agricultural
	Land ownership (Govt. Pvt., tribal, non-tribal etc.)	Private
33	Approaches for construction	Sufficient approach is available
34	Wind Zone	2
35	State	Maharashtra
36	District	Osmanabad

DETAILS OF MAJOR CROSSINGS ENCOUNTERED IN PROPOSED ROUTE

NAME OF THE LINE: LILO of both Circuits of Parli (M) – Karjat (M) / Lonikand-II(M) 400 Kv D/c Line (twin moose) at Kallam PS

Power Line Crossing (132 kV & Above)

S.NO	Name of Line	Crossing Between
1	Nil	Nil

River Crossing Details

S.NO	Name of River (Minor - Nadi)	Crossing Between
1	Nil	Nil

Main Road Crossings (NH & SH) Details

S.NO	Name of the Road	Type of Road National Highway/State Highway	Remarks (Crossing Between Loc. No.)
1	Nil	Nil	Nil

Main Railway Crossings Details

S.NO	Name of Railway Line	Nearest Railway Station	Remarks (Crossing Between Loc. No.)
1	Nil	Nil	Nil

Forest Stretches Involved

S.NO	Type of the Forest	Forest Stretches (M)	Remarks (Crossing Between Loc. No.)
1	Nil	Nil	Nil

CHAPTER-1.5

Wind Zone Map

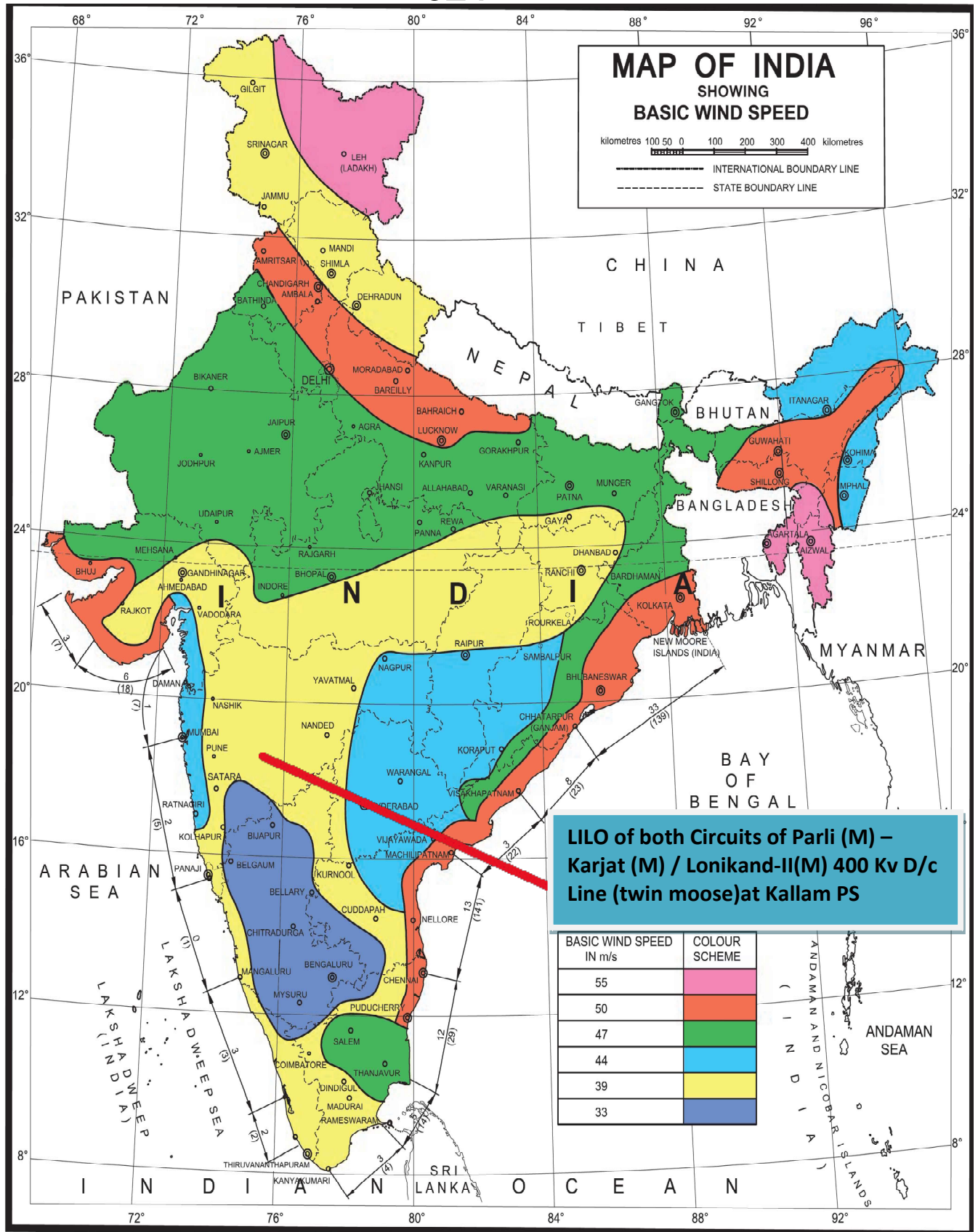

CHAPTER-1.6

Result & Conclusions

Results & Conclusions

Referring to angle point summary and after initial inspection of physical maps updated with satellite images and walk over survey, the proposed corridor for the transmission line was explored for the best route alignment. Special attention has also been given to minimize the crossings like existing EHV lines, forest/reserved forest areas, GIB Priority /GIB Potential area, river crossings, national/state highways alignments, habitation and plantation. After detailed analysis, the proposed transmission line route has been observed as most viable route for alignment of the proposed transmission line.

The Route marked in **Red** in the route alignment drawing is proposed as final route.

CHAPTER-1.7

ROUTE ALIGNMENT MAP ON DIGITIZED TOPOSHEET

Enclosed Separately

328 ANNEXURE P/9 (COLLY.)

Amendment – I dated 15.12.2023 on the Request for Proposal Document and Transmission Service Agreement issued for selection of bidder as Transmission Service Provider to establish “Western Region Network Expansion Scheme in Kallam area of Maharashtra” through tariff based competitive bidding process.

Sl. No.	Clause No.	Existing Provisions	New / Revised Provisions																																				
1.	2.7.1 of RFP	The Bidders should submit the Bids online through the electronic bidding platform before the Bid Deadline i.e., on or before 1400 hours (IST) on 15.12.2023 . In addition to the online submission, the Bidder with lowest Final Offer will be required to submit original hard copies of Annexure 3, Annexure 4 (if applicable), Annexure 6 (if applicable) and Annexure 14 before issuance of Lol.	The Bidders should submit the Bids online through the electronic bidding platform before the Bid Deadline i.e., on or before 1400 hours (IST) on 05.01.2024 . In addition to the online submission, the Bidder with lowest Final Offer will be required to submit original hard copies of Annexure 3, Annexure 4 (if applicable), Annexure 6 (if applicable) and Annexure 14 before issuance of Lol.																																				
2.	2.7.2 of RFP	Important timelines are mentioned below: <table border="1" style="width: 100%; border-collapse: collapse;"> <thead> <tr> <th style="text-align: center;">Date</th> <th style="text-align: center;">Event</th> </tr> </thead> <tbody> <tr> <td style="text-align: center;">15.12.2023</td> <td>Submission of Bid (Online submission of Bid through electronic bidding portal)</td> </tr> <tr> <td style="text-align: center;">15.12.2023</td> <td>Opening of Technical Bid</td> </tr> <tr> <td style="text-align: center;">26.12.2023</td> <td>Shortlisting and announcement of Qualified Bidders on bidding portal</td> </tr> <tr> <td style="text-align: center;">27.12.2023</td> <td>Opening of Financial Bid - Initial Offer</td> </tr> <tr> <td style="text-align: center;">28.12.2023</td> <td>Electronic reverse auction (Financial Bid – Final Offer) for the Qualified Bidders.</td> </tr> <tr> <td style="text-align: center;">02.01.2024</td> <td>Submission of original hard copies of Annexure 3, Annexure 4, Annexure 6, as applicable and Annexure 14 by the bidder with lowest Final Offer</td> </tr> <tr> <td style="text-align: center;">05.01.2024</td> <td>Selection of Successful Bidder and issue of LOI</td> </tr> <tr> <td style="text-align: center;">16.01.2024</td> <td>Signing of RFP Project Documents and transfer of [Insert name of the SPV]</td> </tr> </tbody> </table>	Date	Event	15.12.2023	Submission of Bid (Online submission of Bid through electronic bidding portal)	15.12.2023	Opening of Technical Bid	26.12.2023	Shortlisting and announcement of Qualified Bidders on bidding portal	27.12.2023	Opening of Financial Bid - Initial Offer	28.12.2023	Electronic reverse auction (Financial Bid – Final Offer) for the Qualified Bidders.	02.01.2024	Submission of original hard copies of Annexure 3, Annexure 4, Annexure 6, as applicable and Annexure 14 by the bidder with lowest Final Offer	05.01.2024	Selection of Successful Bidder and issue of LOI	16.01.2024	Signing of RFP Project Documents and transfer of [Insert name of the SPV]	Important timelines are mentioned below: <table border="1" style="width: 100%; border-collapse: collapse;"> <thead> <tr> <th style="text-align: center;">Date</th> <th style="text-align: center;">Event</th> </tr> </thead> <tbody> <tr> <td style="text-align: center;">05.01.2024</td> <td>Submission of Bid (Online submission of Bid through electronic bidding portal)</td> </tr> <tr> <td style="text-align: center;">05.01.2024</td> <td>Opening of Technical Bid</td> </tr> <tr> <td style="text-align: center;">15.01.2024</td> <td>Shortlisting and announcement of Qualified Bidders on bidding portal</td> </tr> <tr> <td style="text-align: center;">16.01.2024</td> <td>Opening of Financial Bid - Initial Offer</td> </tr> <tr> <td style="text-align: center;">17.01.2024</td> <td>Electronic reverse auction (Financial Bid – Final Offer) for the Qualified Bidders.</td> </tr> <tr> <td style="text-align: center;">22.01.2024</td> <td>Submission of original hard copies of Annexure 3, Annexure 4, Annexure 6, as applicable and Annexure 14 by the bidder with lowest Final Offer</td> </tr> <tr> <td style="text-align: center;">25.01.2024</td> <td>Selection of Successful Bidder and issue of LOI</td> </tr> <tr> <td style="text-align: center;">05.02.2024</td> <td>Signing of RFP Project Documents and transfer of KALLAM TRANSCO LIMITED</td> </tr> </tbody> </table>	Date	Event	05.01.2024	Submission of Bid (Online submission of Bid through electronic bidding portal)	05.01.2024	Opening of Technical Bid	15.01.2024	Shortlisting and announcement of Qualified Bidders on bidding portal	16.01.2024	Opening of Financial Bid - Initial Offer	17.01.2024	Electronic reverse auction (Financial Bid – Final Offer) for the Qualified Bidders.	22.01.2024	Submission of original hard copies of Annexure 3, Annexure 4, Annexure 6, as applicable and Annexure 14 by the bidder with lowest Final Offer	25.01.2024	Selection of Successful Bidder and issue of LOI	05.02.2024	Signing of RFP Project Documents and transfer of KALLAM TRANSCO LIMITED
Date	Event																																						
15.12.2023	Submission of Bid (Online submission of Bid through electronic bidding portal)																																						
15.12.2023	Opening of Technical Bid																																						
26.12.2023	Shortlisting and announcement of Qualified Bidders on bidding portal																																						
27.12.2023	Opening of Financial Bid - Initial Offer																																						
28.12.2023	Electronic reverse auction (Financial Bid – Final Offer) for the Qualified Bidders.																																						
02.01.2024	Submission of original hard copies of Annexure 3, Annexure 4, Annexure 6, as applicable and Annexure 14 by the bidder with lowest Final Offer																																						
05.01.2024	Selection of Successful Bidder and issue of LOI																																						
16.01.2024	Signing of RFP Project Documents and transfer of [Insert name of the SPV]																																						
Date	Event																																						
05.01.2024	Submission of Bid (Online submission of Bid through electronic bidding portal)																																						
05.01.2024	Opening of Technical Bid																																						
15.01.2024	Shortlisting and announcement of Qualified Bidders on bidding portal																																						
16.01.2024	Opening of Financial Bid - Initial Offer																																						
17.01.2024	Electronic reverse auction (Financial Bid – Final Offer) for the Qualified Bidders.																																						
22.01.2024	Submission of original hard copies of Annexure 3, Annexure 4, Annexure 6, as applicable and Annexure 14 by the bidder with lowest Final Offer																																						
25.01.2024	Selection of Successful Bidder and issue of LOI																																						
05.02.2024	Signing of RFP Project Documents and transfer of KALLAM TRANSCO LIMITED																																						

3.	2.13.1 of RFP	<p>.....</p> <p>Opening of Envelope (Technical Bid): 1430 hours (IST) on <u>15.12.2023</u></p> <p>.....</p> <p>Opening of Initial Offer: Initial Offer shall be opened by the Bid Opening Committee in presence of the Bid Evaluation Committee at 1430 hours (IST) on <u>27.12.2023</u> in the office of CEA.</p>	<p>.....</p> <p>Opening of Envelope (Technical Bid): 1430 hours (IST) on <u>05.01.2024</u></p> <p>.....</p> <p>Opening of Initial Offer: Initial Offer shall be opened by the Bid Opening Committee in presence of the Bid Evaluation Committee at 1430 hours (IST) on <u>16.01.2024</u> in the office of CEA.</p>
4.	RFP & TSA	Name of the Project Specific SPV	All the reference to the name of the SPV may be read as " <u>KALLAM TRANSCO LIMITED</u> ".

Amendment – II dated 27.12.2023 on the Request for Proposal Document and Transmission Service Agreement issued for selection of bidder as Transmission Service Provider to establish “Western Region Network Expansion Scheme in Kallam area of Maharashtra” through tariff based competitive bidding process.

Sl. No.	Clause No.	Existing Clause	New/Revised Clause																																				
1	B.1.2 (vi)	New clause added.	<p>B.1.2 (vi) Kallam S/S:</p> <p><u>400kV: Bays identified for LILO of both circuits of Parli(M) – Karjat(M)/Lonikand-II (M) 400 kV D/c line are shown in attached SLD & GA drawing of Kallam S/S. As per the GA drawing out of 4 circuits, 3 circuits shall be terminated in new diameters for which main & tie bays are to be constructed under the present scope. Remaining 1 circuit shall be terminated in main bay no. 419 under present scope for which tie bay is excluded as the same is being constructed in separate scheme.</u></p> <p><u>Further, Line gantries shall be constructed for termination of all the four (4) circuits considering the provision of switchable line reactor as shown in GA drawing.</u></p>																																				
2	RFP Specific Technical Requirements for Substation Clause No. B.5.0	<p>B.5.0 EXTENSION OF EXISTING SUBSTATION</p> <p>The following drawings/details of existing substation are attached with the RFP documents for further engineering by the bidder.</p> <table border="1"> <thead> <tr> <th>Sl. No</th> <th>Drawing Title</th> <th>Drawing No./Details</th> <th>Rev. No.</th> </tr> </thead> <tbody> <tr> <td>A</td> <td colspan="3">400kV Kallam S/S</td> </tr> <tr> <td>1.</td> <td>Single Line Diagram</td> <td><u>Drawings for previous scheme are yet to be</u></td> <td></td> </tr> <tr> <td>2.</td> <td>General Arrangement</td> <td></td> <td></td> </tr> </tbody> </table>	Sl. No	Drawing Title	Drawing No./Details	Rev. No.	A	400kV Kallam S/S			1.	Single Line Diagram	<u>Drawings for previous scheme are yet to be</u>		2.	General Arrangement			<p>B.5.0 EXTENSION OF EXISTING SUBSTATION</p> <p>The following drawings/details of existing substation are attached with the RFP documents for further engineering by the bidder.</p> <table border="1"> <thead> <tr> <th>Sl. No</th> <th>Drawing Title</th> <th>Drawing No./Details</th> <th>Rev. No.</th> </tr> </thead> <tbody> <tr> <td>A</td> <td colspan="3">400kV Kallam S/S</td> </tr> <tr> <td>1</td> <td>Single Line Diagram</td> <td><u>IGT-KTL-ELEC-SLD-001</u></td> <td>-</td> </tr> <tr> <td>2</td> <td>General Arrangement</td> <td><u>IGT-KTL-ELEC-LAY-001</u></td> <td>-</td> </tr> <tr> <td>3</td> <td>Earth Mat Layout</td> <td><u>Drawings for previous scheme are</u></td> <td></td> </tr> </tbody> </table>	Sl. No	Drawing Title	Drawing No./Details	Rev. No.	A	400kV Kallam S/S			1	Single Line Diagram	<u>IGT-KTL-ELEC-SLD-001</u>	-	2	General Arrangement	<u>IGT-KTL-ELEC-LAY-001</u>	-	3	Earth Mat Layout	<u>Drawings for previous scheme are</u>	
Sl. No	Drawing Title	Drawing No./Details	Rev. No.																																				
A	400kV Kallam S/S																																						
1.	Single Line Diagram	<u>Drawings for previous scheme are yet to be</u>																																					
2.	General Arrangement																																						
Sl. No	Drawing Title	Drawing No./Details	Rev. No.																																				
A	400kV Kallam S/S																																						
1	Single Line Diagram	<u>IGT-KTL-ELEC-SLD-001</u>	-																																				
2	General Arrangement	<u>IGT-KTL-ELEC-LAY-001</u>	-																																				
3	Earth Mat Layout	<u>Drawings for previous scheme are</u>																																					

Sl. No.	Clause No.	Existing Clause				New/Revised Clause			
		3.	Earth Mat Layout	<u>finalized by the developer</u>		4	Visual Monitoring System	<u>yet to be finalized by the developer</u>	
		4.	Visual Monitoring System			5	Bus Bar Protection		
		5.	Bus Bar Protection			6	Substation Automation System (SAS)	<u>GE Make</u>	-
		6.	Substation Automation System (SAS)						

Amendment – III dated 04.01.2024 on the Request for Proposal Document and Transmission Service Agreement issued for selection of bidder as Transmission Service Provider to establish “Western Region Network Expansion Scheme in Kallam area of Maharashtra” through tariff based competitive bidding process.

Sl. No.	Clause No.	Existing Provisions	New / Revised Provisions																																				
1.	2.7.1 of RFP	The Bidders should submit the Bids online through the electronic bidding platform before the Bid Deadline i.e., on or before 1400 hours (IST) on 05.01.2024 . In addition to the online submission, the Bidder with lowest Final Offer will be required to submit original hard copies of Annexure 3, Annexure 4 (if applicable), Annexure 6 (if applicable) and Annexure 14 before issuance of Lol.	The Bidders should submit the Bids online through the electronic bidding platform before the Bid Deadline i.e., on or before 1400 hours (IST) on 19.01.2024 . In addition to the online submission, the Bidder with lowest Final Offer will be required to submit original hard copies of Annexure 3, Annexure 4 (if applicable), Annexure 6 (if applicable) and Annexure 14 before issuance of Lol.																																				
2.	2.7.2 of RFP	Important timelines are mentioned below: <table border="1" data-bbox="262 803 1129 1307"> <thead> <tr> <th>Date</th> <th>Event</th> </tr> </thead> <tbody> <tr> <td>05.01.2024</td> <td>Submission of Bid (Online submission of Bid through electronic bidding portal)</td> </tr> <tr> <td>05.01.2024</td> <td>Opening of Technical Bid</td> </tr> <tr> <td>15.01.2024</td> <td>Shortlisting and announcement of Qualified Bidders on bidding portal</td> </tr> <tr> <td>16.01.2024</td> <td>Opening of Financial Bid - Initial Offer</td> </tr> <tr> <td>17.01.2024</td> <td>Electronic reverse auction (Financial Bid – Final Offer) for the Qualified Bidders.</td> </tr> <tr> <td>22.01.2024</td> <td>Submission of original hard copies of Annexure 3, Annexure 4, Annexure 6, as applicable and Annexure 14 by the bidder with lowest Final Offer</td> </tr> <tr> <td>25.01.2024</td> <td>Selection of Successful Bidder and issue of LOI</td> </tr> <tr> <td>05.02.2024</td> <td>Signing of RFP Project Documents and transfer of KALLAM TRANSCO LIMITED</td> </tr> </tbody> </table>	Date	Event	05.01.2024	Submission of Bid (Online submission of Bid through electronic bidding portal)	05.01.2024	Opening of Technical Bid	15.01.2024	Shortlisting and announcement of Qualified Bidders on bidding portal	16.01.2024	Opening of Financial Bid - Initial Offer	17.01.2024	Electronic reverse auction (Financial Bid – Final Offer) for the Qualified Bidders.	22.01.2024	Submission of original hard copies of Annexure 3, Annexure 4, Annexure 6, as applicable and Annexure 14 by the bidder with lowest Final Offer	25.01.2024	Selection of Successful Bidder and issue of LOI	05.02.2024	Signing of RFP Project Documents and transfer of KALLAM TRANSCO LIMITED	Important timelines are mentioned below: <table border="1" data-bbox="1165 803 2032 1307"> <thead> <tr> <th>Date</th> <th>Event</th> </tr> </thead> <tbody> <tr> <td>19.01.2024</td> <td>Submission of Bid (Online submission of Bid through electronic bidding portal)</td> </tr> <tr> <td>19.01.2024</td> <td>Opening of Technical Bid</td> </tr> <tr> <td>29.01.2024</td> <td>Shortlisting and announcement of Qualified Bidders on bidding portal</td> </tr> <tr> <td>30.01.2024</td> <td>Opening of Financial Bid - Initial Offer</td> </tr> <tr> <td>31.01.2024</td> <td>Electronic reverse auction (Financial Bid – Final Offer) for the Qualified Bidders.</td> </tr> <tr> <td>05.02.2024</td> <td>Submission of original hard copies of Annexure 3, Annexure 4, Annexure 6, as applicable and Annexure 14 by the bidder with lowest Final Offer</td> </tr> <tr> <td>08.02.2024</td> <td>Selection of Successful Bidder and issue of LOI</td> </tr> <tr> <td>19.02.2024</td> <td>Signing of RFP Project Documents and transfer of KALLAM TRANSCO LIMITED</td> </tr> </tbody> </table>	Date	Event	19.01.2024	Submission of Bid (Online submission of Bid through electronic bidding portal)	19.01.2024	Opening of Technical Bid	29.01.2024	Shortlisting and announcement of Qualified Bidders on bidding portal	30.01.2024	Opening of Financial Bid - Initial Offer	31.01.2024	Electronic reverse auction (Financial Bid – Final Offer) for the Qualified Bidders.	05.02.2024	Submission of original hard copies of Annexure 3, Annexure 4, Annexure 6, as applicable and Annexure 14 by the bidder with lowest Final Offer	08.02.2024	Selection of Successful Bidder and issue of LOI	19.02.2024	Signing of RFP Project Documents and transfer of KALLAM TRANSCO LIMITED
Date	Event																																						
05.01.2024	Submission of Bid (Online submission of Bid through electronic bidding portal)																																						
05.01.2024	Opening of Technical Bid																																						
15.01.2024	Shortlisting and announcement of Qualified Bidders on bidding portal																																						
16.01.2024	Opening of Financial Bid - Initial Offer																																						
17.01.2024	Electronic reverse auction (Financial Bid – Final Offer) for the Qualified Bidders.																																						
22.01.2024	Submission of original hard copies of Annexure 3, Annexure 4, Annexure 6, as applicable and Annexure 14 by the bidder with lowest Final Offer																																						
25.01.2024	Selection of Successful Bidder and issue of LOI																																						
05.02.2024	Signing of RFP Project Documents and transfer of KALLAM TRANSCO LIMITED																																						
Date	Event																																						
19.01.2024	Submission of Bid (Online submission of Bid through electronic bidding portal)																																						
19.01.2024	Opening of Technical Bid																																						
29.01.2024	Shortlisting and announcement of Qualified Bidders on bidding portal																																						
30.01.2024	Opening of Financial Bid - Initial Offer																																						
31.01.2024	Electronic reverse auction (Financial Bid – Final Offer) for the Qualified Bidders.																																						
05.02.2024	Submission of original hard copies of Annexure 3, Annexure 4, Annexure 6, as applicable and Annexure 14 by the bidder with lowest Final Offer																																						
08.02.2024	Selection of Successful Bidder and issue of LOI																																						
19.02.2024	Signing of RFP Project Documents and transfer of KALLAM TRANSCO LIMITED																																						

3.	2.13.1 of RFP	<p>.....</p> <p>Opening of Envelope (Technical Bid): 1430 hours (IST) on <u>05.01.2024</u></p> <p>.....</p> <p>Opening of Initial Offer: Initial Offer shall be opened by the Bid Opening Committee in presence of the Bid Evaluation Committee at 1430 hours (IST) on <u>16.01.2024</u> in the office of CEA.</p>	<p>.....</p> <p>Opening of Envelope (Technical Bid): 1430 hours (IST) on <u>19.01.2024</u></p> <p>.....</p> <p>Opening of Initial Offer: Initial Offer shall be opened by the Bid Opening Committee in presence of the Bid Evaluation Committee at 1430 hours (IST) on <u>30.01.2024</u> in the office of CEA.</p>
3.	Para 5.1.4 of TSA	<p>The TSP shall be responsible for</p> <p>(a) <u>[To be deleted by the BPC in case no land acquisition is involved in the Project and replaced by "deleted"] acquisition of land for location specific substations, switching stations or HVDC terminal or inverter stations. Also, the actual location of Greenfield substations (Switching Stations or HVDC Terminal or Inverter Stations) for a generation pooling substation and for load serving substations in the scope of TSP shall not be beyond 3 Km radius of the location proposed by the BPC in the survey report. However, actual location of any Greenfield Intermediate Substations in the scope of TSP shall not be beyond 10 Km radius of the location proposed by the BPC in the Survey Report.</u></p> <p>(b) <u>[To be deleted by the BPC in case no land acquisition is involved in the Project and replaced by "deleted"] final selection of Site including its geo-technical investigation;</u></p>	<p>The TSP shall be responsible for</p> <p>(a) <u>deleted</u></p> <p>(b) <u>deleted</u></p>

Amendment – IV dated 15.01.2024 on the Request for Proposal Document issued for selection of bidder as Transmission Service Provider to establish “Western Region Network Expansion Scheme in Kallam area of Maharashtra” through tariff based competitive bidding process

Sl. No.	Clause No.	Existing Clause	New/Revised Clause
1	Amendment-II (Clause B.1.2 (vi) of RfP)	<p>B.1.2 (vi) Kallam S/S:</p> <p>400kV: Bays identified for LILO of both circuits of Parli(M) – Karjat(M)/Lonikand-II (M) 400 kV D/c line are shown in attached SLD & GA drawing of Kallam S/S. As per the GA drawing out of 4 circuits, 3 circuits shall be terminated in new diameters for which main & tie bays are to be constructed under the present scope. Remaining 1 circuit shall be terminated in main bay no. 419 under present scope for which tie bay is excluded as the same is being constructed in separate scheme.</p> <p>Further, Line gantries shall be constructed for termination of all the four (4) circuits considering the provision of switchable line reactor as shown in GA drawing.</p>	<p>B.1.2 (vi) Kallam S/S:</p> <p>400kV: Bays identified for LILO of both circuits of Parli(M) – Karjat(M)/Lonikand-II (M) 400 kV D/c line are shown in attached SLD & GA drawing of Kallam S/S. As per the GA drawing out of 4 circuits, 3 circuits shall be terminated in existing diameters for which main bays are to be constructed under the present scope. These 3 circuits shall be terminated in main bay nos. 413, 416 & 419 respectively. Remaining 1 circuit shall be terminated in new diameter for which main & tie bays are to be constructed under present scope.</p> <p>Further, Line gantries shall be constructed for termination of all the four (4) circuits considering the provision of switchable line reactor as shown in GA drawing.</p>



Ref No: RECPDCL/TBCB/Kallam/2023-24/ **2583**

Date: 06.11.2023

M/s IndiGrid 2 Limited,
Unit No 101, 1st Floor, Windsor Village,
KoleKalyan Off CST Road, Vidyanagari Marg,
Santacruz (East) Mumbai, Maharashtra, Pin- 400098.

Kind attention: Mr. Wasim Alam, Senior Manager - Bidding & BD

Subject: Selection of Bidder as Transmission Service Provider (TSP) to establish Transmission System for "Western Region Network Expansion Scheme in Kallam area of Maharashtra" to be implemented through Tariff Based Competitive Bidding (TBCB) process.

Dear Sir,

This has reference to RFP document issued to you for subject cited project.

In this regard, it is to inform that as per provisions of RFP documents, the Pre-Bid meeting through Video Conferencing has been scheduled on 08.11.2023 at 1630 Hrs (IST). The link is given below:

<https://meet.google.com/roo-rkse-qrz>

Kindly make it convenient to attend the meeting. Further, maximum two persons will be allowed to join the VC from each organization.

Thanking you,

Yours faithfully,

(P S Hariharan)

Chief General Manager (Tech)

Encl.: As above

Ref No: RECPDCL/TBCB/Kallam/2023-24/3094

Date: 11.12.2023

Mr. Wasim Alam, Senior Manager - Bidding & BD,

M/s IndiGrid 2 Limited,

Unit No 101, First Floor,

Windsor Village, KoleKalyan Off CST Road,

Vidyanagari Marg, Santacruz (East) Mumbai,

Maharashtra - 4000098.

Subject: Selection of Bidder as Transmission Service Provider (TSP) to establish transmission system for "Western Region Network Expansion Scheme in Kallam area of Maharashtra" to be implemented through Tariff Based Competitive Bidding process.

Dear Sir,

This has reference to the RFP dated 13.10.2023 for selection of Transmission Service Provider to establish Transmission System for "Western Region Network Expansion Scheme in Kallam area of Maharashtra" (hereinafter referred to as "the Project") through tariff based competitive bidding process.

As per the requirement of Clause 1.5 of RFP, we would like to intimate you that the Tentative Acquisition Price payable by the Selected Bidder to the BPC for the acquisition of one hundred percent (100%) of the equity shareholding of KALLAM TRANSCO LIMITED, along with all its related assets and liabilities is **Rs. 640.66 Lakhs (Rupees Six Crore Forty Lakh Sixty-Six Thousand only)**. This Acquisition Price shall be subject to adjustment based on the audited accounts of KALLAM TRANSCO LIMITED as on the date of execution of the Share Purchase Agreement.

As per clause no. 3.5 of revised guidelines issued vide Gazette Notification dated 10.08.2021 for BPC (Bid Process Coordinator), price variation between Tentative Acquisition Price and the amount to be paid finally at the end of bidding process by selected bidder should not be more than 5%.

It is further to inform that "Change in Law" would not be applicable on account of Tentative Acquisition Price variation within above mentioned limit.

It may please be noted that as on date, there are no contractual obligations undertaken by BPC on behalf of KALLAM TRANSCO LIMITED which are to be fulfilled by the TSP.

All other terms and conditions of the RFP remain the same.

Thanking you,

Yours faithfully,

(P S Hariharan)

Chief General Manager (Tech)

Ref No: RECPDCL/TBCB/Kallam/2023-24/ 3260

Date: 18.12.2023

Mr. Wasim Alam, Senior Manager - Bidding & BD,
M/s IndiGrid 2 Limited,
Unit No 101, First Floor,
Windsor Village, KoleKalyan Off CST Road,
Vidyanagari Marg, Santacruz (East) Mumbai,
Maharashtra - 4000098.

Subject: Selection of Bidder as Transmission Service Provider (TSP) to establish transmission system for "Western Region Network Expansion Scheme in Kallam area of Maharashtra" through Tariff Based Competitive Bidding process. –
Regarding drawings of existing Kallam S/s.

Dear Sir,

This has reference to the RFP dated 13.10.2023 for selection of Transmission Service Provider to establish Transmission System for "Western Region Network Expansion Scheme in Kallam area of Maharashtra" (hereinafter referred to as "the Project") through tariff based competitive bidding process.

In this regard, please find attached drawings (Single line Diagram and General Arrangement) of existing Kallam sub-station.

For all future references, the RFP documents should be read and referred to after including these drawings.

All other terms & conditions of the RFP remain the same.

Thanking you,

Yours faithfully,



(P S Hariharan)
Chief General Manager (Tech)

Encl.: As above

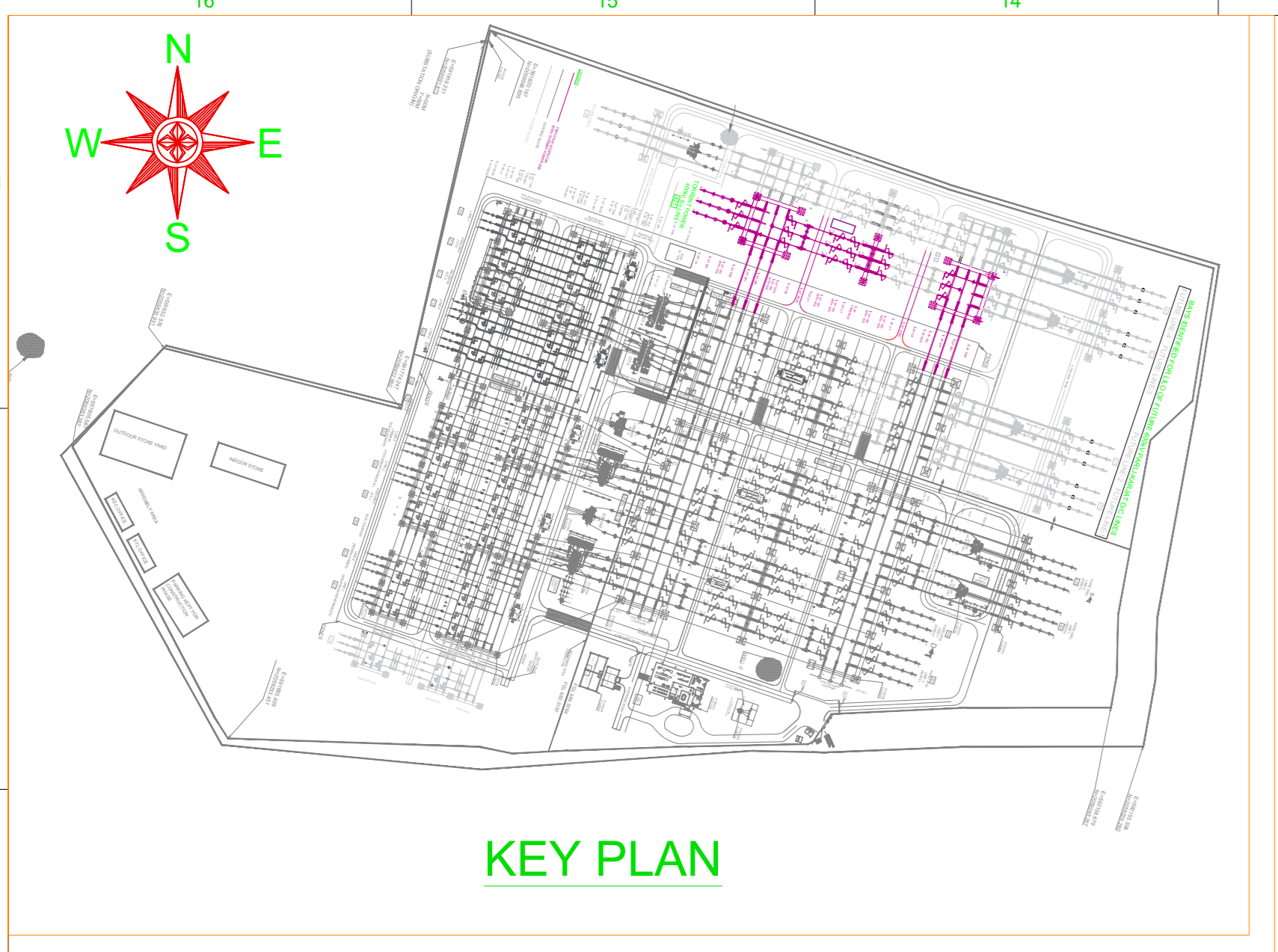

CLIENT: KALLAM TRANSMISSION LIMITED Regd. Office: A-520, GF, AI Extn, Badarpur, New Delhi-110044, India.	
TITLE: ELECTRICAL LAYOUT (PLAN)	
DIVISION: SUBSTATION ELECTRICAL	DATE:
DWG.NO.: IGT-KTL-ELEC-LAY-001	SCALE: 1:1
CLIENT DRG. NO.	REV. SHEET: 1 OF 1

REV	DATE	DESCRIPTION	DRN	CHD	APP
-----	------	-------------	-----	-----	-----

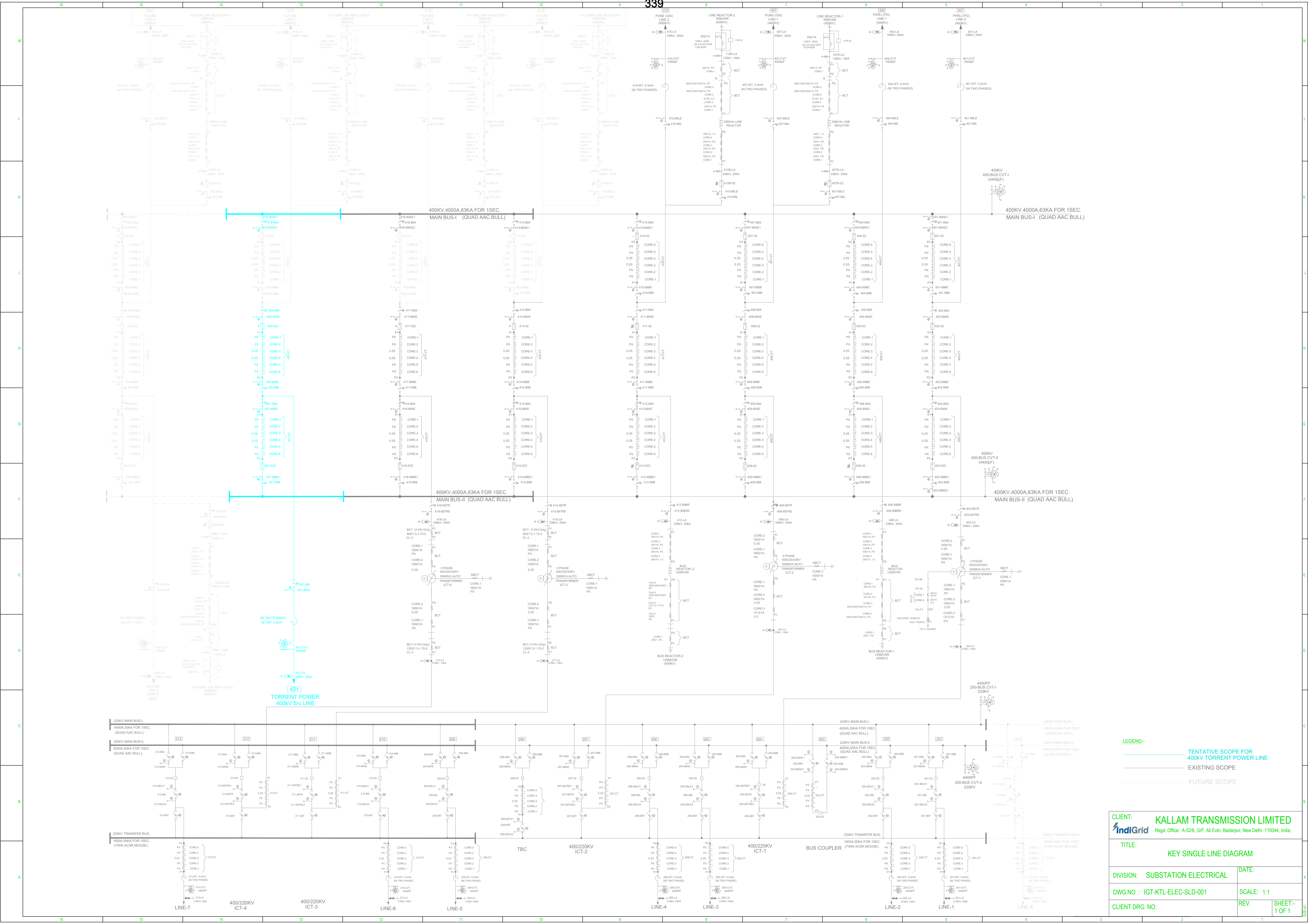

LEGEND:-
 ——— TENTATIVE SCOPE FOR 400KV TORRENT POWER LINE
 ——— EXISTING SCOPE
 - - - - FUTURE SCOPE

CLIENT: **KALLAM TRANSMISSION LIMITED**
 IndiGrid Regd. Office: A-52/6, G/F, Ali Extn, Badarpur, New Delhi-110044, India.

TITLE: **KEY SINGLE LINE DIAGRAM**

DIVISION: **SUBSTATION ELECTRICAL** DATE: _____

DWG.NO.: **IGT-KTL-ELEC-SLD-001** SCALE: **1:1**

CLIENT DRG. NO: _____ REV. _____ SHEET- **1 OF 1**

340 ANNEXURE P/13 (COLLY.)

Clarifications dated 27.12.2023 on RFP Project Documents for selection of Bidder as Transmission Service Provider to establish Transmission System for "Western Region Network Expansion scheme in Kallam area of Maharashtra " through tariff based competitive bidding process.

S. No.	Name of the document	Clause No. and Existing provision			Clarification required	Suggested text for the Amendment	Rationale for the Clarification or Amendment	RECPDCL Response
1.	RFP	General			Kindly confirm: i) whether the Project / Elements are covered under "Generation linked Project" or "System Strengthening Project"			The subject scheme has been approved as "Western Region Network Expansion scheme in Kallam area of Maharashtra".
2.	RFP	General			Kindly confirm: i) Whether the Project/ Elements are eligible for early commissioning incentive as per MoP, GoI order dated 15.07.2015.			The provisions in TSA pertaining to commissioning shall prevail which interalia covers the matter of preponing of CoD. The TSP may approach the Committee constituted by MoP vide its OM No. 15/1/2013-Trans dated 14.12.2021 to ensure smooth operationalization of the Policy for early commissioning.
3.	Scope of Transmission scheme, RFP	Sl. No.	Name of Transmission Element	Scheduled COD in months from Effective Date	LILO of both circuits of Parli(M) - Karjat(M)/Lonikand-II (M) 400 kV D/c line (twin moose) at Kallam PS: Kindly provide us the Route and KMZ for this line along with the details of LILO points.		Bidder needs information for clarity and proper estimation	The Survey Report has been already issued to the bidders. The land within the existing Kallam PS will be given free of cost to successful bidder in as is where is basis. Further, Bidder may visit the site
1	LILO of both circuits of Parli(M) -	18 Months						

			<p>Karjat(M)/Lon ikand-II (M) 400 kV D/c line (twin moose) at Kallam PS</p>		<p>Extension of 400 kV Kallam PS:</p> <p>Confirm whether the land shall be provided on lease basis or on free of cost. If on lease basis, kindly provide the charges.</p> <p>What is the timeline for handling over of land for construction.</p> <p>O&M of these bays are in the scope of TSP or Developer of Kallam PS i.e. Kallam Transmission Ltd. Kindly confirm.</p> <p>Conversion of 50 MVAR fixed line reactors on each ckt. at Parli (M) end of Kallam - Parli (M) 400kV D/c line to switchable line reactors:</p> <p>Kindly clarify modalities for tariff, O&M, land availability and its charges, shutdown of line and reactors during construction period etc. for conversion of fixed line reactors to switchable line reactors.</p> <p>Kindly clarify modalities for tariff, O&M for switching equipment to convert fixed</p>			<p>and acquaint themselves with the site conditions. Please refer Clause No 2.5.7 of RFP Document.</p> <p>RfP in respect of O&M is amply clear. Further, CEA's "Operation and Maintenance (O&M) guidelines and Standard Format for Memorandum of Understanding between New TSP and Existing TSP" issued by CEA vide its letter No. I/28514/2023 dated 22.06.2023 to be followed. Copy of the guideline is available on CEA website at following link:</p> <p>https://cea.nic.in/wp-content/uploads/pse__td/2023/06/om_guidelines.pdf</p>
		2	<p>4 Nos. 400 kV line bays at Kallam PS for LILO of both circuits of Parli(M) - Karjat(M)/Lon ikand-II(M) 400 kV D/c line (twin moose) at Kallam PS</p> <ul style="list-style-type: none"> 400 kV line bays (AIS) - 4 Nos. (for Kallam PS end) 					
		3	<p>63 MVAR, 420 kV switchable line reactor (with NGR bypassing arrangement) on each ckt at Kallam PS end of Karjat - Kallam 400 kV</p>					

		<p>D/c line (~140km)</p> <ul style="list-style-type: none"> 63 MVAR, 420 kV switchable line reactor including Switching equipment - 2 Nos. (at Kallam end) 	<p>line reactors into switchable line reactors.</p> <p>In case, Tariff for these switching equipment is to be paid to TSP, then clarify the following:</p> <p>(i) Confirm whether the land shall be provided on lease basis or on free of cost. If on lease basis, kindly provide the charges.</p> <p>(ii) What is the timeline for handling over of land for construction.</p> <p>(iii) Modalities of shutdown requirement during construction period.</p>			
<p>Note:</p> <p>(i) TSP of Kallam PS (Kallam Transmission Ltd.) shall provide requisite space at Kallam PS for above mentioned scope of work.</p> <p>(ii) The 50 MVAR fixed line reactors on each ckt at Parli (M) end of Kallam - Parli (M) 400kV D/c line shall be converted into switchable line reactors (with NGR bypass arrangement & provision of inter-tripping scheme to trip the line reactors along with the main line breakers) by MSETCL in matching time-frame of the</p>						

		above scheme. MSETCL vide email dated 08.06.2023 has informed that conversion of fixed 50 MVAR line reactor at 400 kV Parli (M) (Girwali) end into switchable reactor is feasible.				
4.	Survey Report	Chapter-1.3 (Coordinates of Proposed Route) Page no 19	Please clarify whether Two Double circuit or Single Multi Circuit towers to be considered for LILO of both Circuits of Parli (M) – Karjat (M) / Lonikand-II(M) 400 Kv D/c Line (twin moose) at Kallam PS	As per Survey Report only one line is shown, where in as per RfP it is written as LILO of both circuits. To avoid the ambiguity and clarity, we want to understand that whether bidder can construct two D/c independent line or one M/c line from end to end.	Survey Report	The survey report has been already issued to the bidders following indicative route/corridor for the proposed transmission line. Bidder may decide on considering two double circuit or single multi circuit towers as per their site assessment and provisions of the RfP document, that states, 400kV transmission line shall be D/C except for areas mentioned under clause A.18.0.
5.	RFP for Selection of Bidder as Transmissi	Special Technical requirement for Transmission Line	For transmission line, no special requirement is specified for type of Insulator and creepage in RFP document.		Bidder needs information for proper estimation.	The minimum specific creepage distances shall be decided for the pollution condition in the area of installation. It shall

	on Service Provider		Hence it is understood that bidder can decide the type of insulator along with creepage requirement based on general CEA regulations and relevant standards. Kindly confirm.			be as per CEA regulations and relevant standards.
6.	RFP for Selection of Bidder as Transmission Service Provider	Clause 1.2 Note b The 50 MVAR fixed line reactors on each ckt at Parli (M) end of Kallam – Parli (M) 400 kV D/c line shall be converted into switchable line reactors	BPC is requested to provide existing SLD and GA drawing of Parli SS with scope of work and location clearly marked on it.		Bidder needs the information for proper estimation	The scope at Parli (M) shall be done by MSETCL. Thus, SLD & GA of Parli (M) is not relevant for the bidder.
7.	RFP for Selection of Bidder as Transmission Service Provider	Clause 1.2 Note: a) TSP of Kallam PS (Kallam Transmission Ltd.) shall provide requisite space at Kallam PS for above scope of work	We understand that the mentioned space for execution of scope of work will be provided free of cost to the TSP. Please confirm.		Bidder needs the information for proper estimation	The land within the existing Kallam PS will be given free of cost to successful bidder in as is where is basis. Further, Bidder may visit the site and acquaint themselves with the site conditions. Please refer Clause No 2.5.7 of RFP Document.
8.	RFP for Selection of Bidder as Transmission Service Provider	Clause 1.2 4 Nos. 400 kV line bays at Kallam PS for LILO of both circuits of Parli(M) – Karjat(M)/Lonikand-II(M) 400 kV D/c line (twin moose) at Kallam PS	We understand TSP must follow RFP requirement only. Existing station owner practice and requirement is not binding on TSP for other than interface points.		Bidder needs the information for proper estimation	Query is not related to the referred clause of RfP. However, Bidder shall meet the requirement of RfP.
9.	TSA: Clause 2.2.2	It is required that post the Expiry Date, the TSP to transfer the Project to CTU within a period of 90 days.	BPC to clarify the following: a. Who will be responsible for O&M of the Project post Expiry Date till the Project is transferred as the Agreement		Bidder needs the information for proper estimation	The transfer of all project assets along with substation land, right of way and clearances shall be completed at the end of

			will automatically terminate on Expiry Date? b. Whether the TSP will be paid for the O&M for the period post Expiry Date till the Project is transferred if the TSP will manage the O&M post Expiry Date?			35 years from COD of the Project. All the expenditure till the transfer of all project assets along with substation land, right of way and clearances shall be borne by TSP.
10.	TSA: 5.1.4.(a)	The actual location of substations, switching stations or HVDC terminal or inverter stations shall not be beyond 3 Km radius of the location proposed by the BPC in the survey report. The actual location of Greenfield substations for a generation pooling substation and for load serving substations shall not be beyond 3 Km radius of the location proposed by the BPC in the survey report. However, actual location of any Greenfield intermediate Substations in the scope of TSP shall not be beyond 10 Km radius of the location proposed by the BPC in the survey report.	BPC to clarify that in case no land is available for substations, switching stations or HVDC terminal or inverter stations within 3 KM/10KM radius of the location proposed by the BPC in the survey report, whether the selected bidder can opt for the land beyond 3KM/10KM?		Bidder needs the information for proper estimation	Scope of work is amply clear in this regard & shall prevail.
11.	TSA: Schedule 1	The Scheduled COD of the Project is 18 months from SPV transfer/ acquisition. The Scheduled COD for each Element is 18 months from Effective Date.	BPC to clarify that Whether the SCOD for the Project (i.e., up to SPV transfer) is different from SCOD for each element (i.e., up to Effective Date)?		Bidder needs the information for proper estimation	Provisions in TSA/RFP are amply clear in this context. As per the scope of subject transmission scheme, the SCOD of all the elements and the project shall be 18 months from SPV transfer/effective date.
12.	RFP	FAQ Clause 2.2 &	We understand that CEA Operation and Maintenance (O&M) guidelines dt. 22.06.2023 shall prevail for		Bidder needs the information	CEA's "Operation and Maintenance (O&M) guidelines and Standard Format for Memorandum

		CEA Operation and Maintenance (O&M) guidelines dt. 22.06.2023	the bay O&M charges at Kallam SS. BPC to please confirm.		for proper estimation.	of Understating between New TSP and Existing TSP” issued by CEA vide its letter No. I/28514/2023 dated 22.06.2023 to be followed. Copy of the guideline is available on CEA website at following link: https://cea.nic.in/wp-content/uploads/pse_td/2023/06/om_guidelines.pdf
13.	RFP & TSA	Clause 1.6.1.1 Further, the actual location of substations, switching stations or HVDC terminal or inverter stations in the scope of TSP shall not be beyond 3 Km radius of the location proposed by the BPC in the survey report. & MOP letter dt.16.06.2023 Amendment in the SBD	BPC to please confirm whether Ishanagar SS under the present scope of work shall be classified as generating pooling substation, load serving substation or greenfield intermediate substation.		Bidder needs the information for proper estimation.	Ishanagar S/S is not in the scope of subject transmission scheme.
14.	RFP	RFP, Section-2 Clause 2.6, Note “Note: List of Element(s) along with the critical Element(s) to be provided by CEA”	We understand that of List of Element(s) along with the critical Element(s) are defined under clause no 2.6.1. and there will no separate list of Elements(s) to be provided by CEA.		Bidder needs the information for proper estimation.	All the elements mentioned at clause 2.6 of RFP are critically important. There is no such additional critical element other than the elements mentioned in the clause 2.6.
15.	Transmission Service Agreement	TSA ARTICLE: 5, Clause no. 5.5.6 - For any delay in commissioning any critical Element(s), as identified in Schedule 1 & Schedule 2 of this Agreement, beyond a period of 45 days	We understand that of List of Element(s) along with the critical Element(s) are defined under clause no 2.6.1. and there will no separate list of Elements(s) to be provided by CEA.		Bidder needs the information for proper estimation.	All the elements mentioned in the schedule 1 and Schedule 2 of the TSA are critically important.

		shall lead to a sequestration of 10% of the Contract Performance Guarantee.				
16.	TSA	Schedule 2 The SCOD for all the elements will be 18 months from the date of SPV acquisition, whereas the SCOD for the project shall be 18 Months (defined term also) from effective date.	BPC to clarify that why the different SCODs have been provided for all the Elements and the Project?		Bidder needs information for proper estimation.	Provisions in TSA/RFP are amply clear in this context. As per the scope of subject transmission scheme, the SCOD of all the elements and the project shall be 18months from SPV transfer/effective date.
17.	Clause no: B 5.0	Bidder is also advised to visit the substation sites and acquaint themselves with the topography, infrastructure such as requirement ---- ----- -----	It is requested to BPC to provide the information on following points. Soil test report of existing 400 kV Kallam SS. Land Coordinates of Existing Kallam SS.		Bidder needs information for proper estimation.	The survey report has been issued to the bidders. Further, Bidders are requested to visit the substation site to acquaint themselves with site & soil related information's. Existing Substation Coordinate 18°37'25.19"N, 75°52'23.73"E. Bidder may also coordinate with existing S/s owner for exact bay locations during execution stage.
18.	Clause no B.2.3 c) Bus bar Protection of Specific Technical requirement for S/s	B.2.3.c) Bus bar Protection ----- ----- For existing substations, the existing bus bar protection shall be augmented as per requirement	We understand that Existing Busbar protection is Distributed Busbar arrangement. Bay peripheral units (PU) already available at 400kV Kallam Substation for utilization of the same for present scope of work.		Bidder needs information for proper estimation.	Yes, existing Bus bar protection scheme is a distributed type and PUs for future bays are available.

			Kindly confirm our understanding.			
19.	Clause no B.2.3 c) Bus bar Protection of Specific Technical requirement for S/s		BPC to provide Bus bar protection system detail (make & model) for augmentation of existing bus bar protection for Kallam Bay extension.		Bidder needs information for proper estimation.	400kV (Redundant) GE(P741956A6S0700K) And 220kV (Single) GE(P741946A6S0700K)
20.	Clause no B.3.1 c) Bus bar Protection of Specific Technical requirement for S/s	B.3.1 AC & DC power supplies ----- -----For catering the requirements of three phase & single-phase AC and DC supply for various substation equipment (for present and future scope), existing facilities shall be augmented as required.	We understand that spare AC/DC feeder along with MCB/MCCB in existing ACDB & DCDB panels are existing at Kallam S/s, same shall be used by TSP for present scope of work. Further, no capacity augmentation of LT transformer is required at Kallam S/s for accommodating present bays. Kindly confirm our understanding.		Bidder needs information for proper estimation	Capacity augmentation of existing LT transformer is not required. Also, spare feeders are available for future bays. However, bidders are advised to visit the site and acquaint themselves with the actual qty. of spare feeders available.
21.		General	BPC to furnish details of existing SAS system at existing S/s at Kallam. Please confirm the existing SAS at Kallam can accommodate the signals and controls of bays under present scope and TSP need not pay any license fees for the same for proper cost estimation.		Bidder needs information for proper estimation	Bidders are advised to consider the material and scope required for augmentation of SAS in the existing system.
22.		General	We understand that in existing substation, for adjacent future bay,		Bidder needs information	Confirmed.

			gantry/towers shall be suitable for extension. BPC to confirm		for proper estimation	
23.	RFP Document	Clause No:1.2 (a) TSP of Kallam PS (Kallam Transmission Ltd.) shall provide requisite space at Kallam PS for above scope of work.	It is understood that 2 nos. Line Bays with Line reactors & 2 nos line bays are to be developed under the present scope of work in existing diameter at Kallam SS end and No tie bay is envisaged for the same. BPC to confirm.			Please refer GA Drawing being already issued as Appendix A and is again attached with Amendment II for reference.
24.	Clause no B.5.0 Extension of Existing Substation	Extension of Existing Substation The following drawings/details of existing substation is attached with the RFP----- ----- -----	Kindly provide the following documents and drawings for Kallam bay extension before bid submission so that bidder can prepare cost estimation: 1.Single Line Diagram. 2.Overall Electrical layout. 3.Cable trench layout. 4. Firefighting layout. 5. Illumination layout. 6. Scada Architecture. 7.Control room building drawing with panel arrangement layout. 8.Overall Foundation layout drawing. 9.VMS layout. For proper cost estimation.			The tentative SLD and the plan layout already issued as Appendix A and is again attached with Amendment II for reference. All other drawings are in the development stage.
25.	RFP for Selection of Bidder as Transmission Service Provider	Clause 1.2 4 Nos. 400 kV line bays at Kallam PS for LILO of both circuits of Parli(M) - Karjat(M)/Lonikand-II(M) 400 kV D/c line (twin moose) at Kallam PS	BPC is requested to provide following drawings for extension work at Kallam PS S/S: 1. GA drawing with take-off gantry location and scope of		Bidder needs the information for proper estimation	1,2,3&4. The tentative SLD and the plan layout already issued as Appendix A and is again attached with Amendment II for reference. All other

			<p>work clearly marked at both SS</p> <ol style="list-style-type: none"> 2. SLD with scope of work clearly highlighted/marked. 3. Earthmat Layout 4. Cable trench layout 5. Make and Model of SAS 6. Soil Test Report <p>Availability of AC & DC Feeders in LT boards.</p>			<p>drawings are in the development stage.</p> <ol style="list-style-type: none"> 5. Make of existing SAS is GE. 6. Bidder may visit the site and ascertain the soil condition. 7. Spare LT Feeders are to be ascertained through the site visit.
26.	RFP for Selection of Bidder as Transmission Service Provider	B.2.3 Protection Relaying and Control System	BPC may kindly confirm availability of communication ports for integrating new PUs with the existing CUs at existing Kallam S/S		Bidder needs the information for proper estimation	Existing CU has provision for inclusion of new PUs of the future bays. Further, Bidder may visit the site and ascertain the same.
27.	RFP for Selection of Bidder as Transmission Service Provider	B.3.1 AC and DC power supplies	We understand that sufficient space is available in ACDB and DCDB at Kallam S/S for extension work. Also, the existing battery and battery charger at Kallam is sufficient for current extension work. Please confirm.		Bidder needs the information for proper estimation`	Although spare feeders are available for future use, actual qty. of feeders to be ascertained through the site visit. Battery and charger capacity augmentation is not required.
28.	RFP for Selection of Bidder as Transmission Service Provider	B.3.2 Fire Fighting System	We understand that the existing firefighting system is sufficient to accommodate the extension work at Kallam S/S. Please confirm.		Bidder needs the information for proper estimation	Confirmed.

29.	RFP for Selection of Bidder as Transmission Service Provider	B.3.5 Control Room	BPC is requested to confirm the availability of space in the existing control room at Kallam S/S for execution of extension work under current project.		Bidder needs the information for proper estimation	The Bidder need to visit Substation site and verify the requirements.
30.	RFP for Selection of Bidder as Transmission Service Provider	B.3.7 Visual monitoring system (VMS) for watch and ward of substation premises	BPC is requested to provide the make and model of VMS at Kallam SS.		Bidder needs the information for proper estimation	VMS system is supplied by M/s Delcom. Please also refer Amendment-II in this regard.
31.	TSA: Schedule 1	Scope of the Transmission Scheme provides that TSP of Kallam PS (Kallam Transmission Ltd.) shall provide requisite space at Kallam PS for the scope of work.	The performance of scope of work by the selected bidder would depend on provision of space to be provided by TSP of Kallam PS and would be out of control of the selected bidder. BPC to clarify the following: a. Whether the space provided by TSP of Kallam PS for the scope of work will be compatible for the selected bidder for the scope of work? b. Whether the space will be provided by TSP of Kallam PS as free of cost? c. Under which documents or transactions TSP of Kallam PS shall be obligated to provide space to the selected bidder? d. BPC to share the copy of the documents under which TSP of Kallam PS is obligated		Bidder needs the information for proper estimation	<p>a. Bidders are requested to visit the substation site to acquaint themselves with site for allocated space for construction of 400kV Bays.</p> <p>b. Yes. The land will be given free of cost to successful bidder on as is where is basis.</p> <p>c & d. Please refer provisions of the RFP which states that land for construction of 4 Nos. 400 kV line bays at Kallam PS for LILO of both circuits of Parli(M) – Karjat(M)/Lonikand-II(M) 400 kV D/c line (twin moose) shall be provided by the TSP of</p>

			<p>to provide space to the selected bidder.</p> <p>e. In case of any delay on the part of TSP of Kallam PS in providing space to the Selected Bidder, whether the extension of SCOD and reimbursement of the cost will be provided to the selected bidder?</p> <p>f. Whether the delays on the part of TSP of Kallam PS in providing the space will cover under force majeure?</p>			<p>existing Kallam PS to the successful bidder.</p> <p>e & f. Provisions of the RFP Documents is amply clear in this regard and shall prevail.</p>
32.	TSA: Clause 5.1.2	The TSP acknowledges and agrees that it shall not be relieved from any of its obligations under this Agreement or be entitled to any extension of time or any compensation whatsoever by reason of the unsuitability of the Site or Transmission Line route(s).	BPC to clarify that as the space shall be provided by TSP of Kallam PS, who shall be responsible in case of unsuitability of the land provided by TSP of Kallam PS?		Bidder needs the information for proper estimation	<p>Yes. The land will be given free of cost to successful bidder in as is where is basis.</p> <p>Further, Bidders are also requested to visit the substation site to acquaint themselves with land condition & suitability.</p>
33.	Final Survey report	Chapter 1.3 – Co-ordinates of proposed route	Additional Information of Under construction Multi circuit transmission line “LILO of both circuits of Parli (PG) – Pune (GIS) 400kV D/c line at Kallam PS”	Exact coordinates of under construction multi circuit transmission line to help in finalizing the route of proposed “ LILO of both circuits of Parli(M) – Karjat(M)/L ”		The coordinates of under construction Multi circuit transmission line “LILO of both circuits of Parli (PG) – Pune (GIS) 400kV D/c line at Kallam PS” near Kallam PS is given in Annexure A . Bidder may further visit the site and acquaint themselves with the site conditions. Please refer Clause No. 2.5.7 of RFP Document.

				onikand-II (M) 400 kV D/c line (twin moose) at Kallam PS"		
34.	RFP	<p>"Final Offer" shall mean the Quoted Transmission Charges, required to be submitted as part of the Financial Bid on the electronic bidding platform during the e-reverse bidding stage. In case, no Final Offer is received during the e-reverse bidding stage then the lowest "Initial Offer" shall be deemed to be the Final Offer;</p>	<p>Presently, details of L-1 bidder are not displayed on conclusion of e-RA if there is no receipt of counterbids.</p> <p>In case, two bidders have quoted the same L1, they would be under false impression of having L1 tariff of their own and may not offer further competitive offer. In such scenario, e-RA shall end resulting in premature conclusion of e-RA process.</p> <p>It is requested to update the e-RA platform accordingly to reflect the status of L1 bidder under the above scenario.</p>		<p>For transparency of the competitive price discovery through e-RA</p>	<p>As per provisions of RFP, bidders have to quote transmission charges up to 2 decimal points. Therefore, it is practically not possible to have same Initial Offer from two or more bidders.</p> <p>However, if such situation arises, appropriate decision will be taken by the competent authority.</p>
35.	RFP document and TSA	<p>Provisions of RFP</p> <p>Clause 1.5</p> <p>.... The TSP shall ensure transfer of all project assets along with substation land, right of way and clearances to CTU or its successors or an agency as decided by the Central Government after 35 years from COD of project at zero cost and free from any encumbrance and liability. The transfer</p>	<p>Query-1</p> <p>Treatment of tax application at the end of the life of assets.</p> <p>As per section 50C of Income tax act, in case sale consideration received or claimed to be received by seller on sale of land or building or both is less than value adopted by stamp</p>			<p>Query-1, 2 and 5</p> <p>The TSP shall ensure transfer of all project assets along with substation land, right of way and clearances to CTU or its successors or an agency as decided by the Central Government after 35 years from COD of project at zero cost and</p>

	<p>shall be completed within 90 days after 35 years from COD of project failing which CTU shall be entitled to take over the project assets Suo moto.</p> <p>Provisions of TSA</p> <p>Definitions:</p> <p>“Project Assets” shall mean all physical and other assets relating to and forming part of the Project including:</p> <p>(a) rights over the Site for substations, ROW for transmission lines;</p> <p>(b) tangible & intangible assets such as civil works and equipment including foundations, embankments, pavements, electrical systems, communication systems, relief centres, administrative offices, Substations, software, tower and sub-stations designs etc;</p> <p>(c) project facilities situated on the Site;</p> <p>(d) all rights of the TSP under the project agreements;</p> <p>(e) financial assets, such as receivables, security deposits etc;</p> <p>(f) insurance proceeds; and</p> <p>(g) Applicable Permits and authorisations relating to or in</p>	<p>valuation authority (SVA), such value adopted by SVA would become actual sale consideration received or accruing to the seller. Therefore, capital gain would be Valuation as per stamp valuation authority reduced by cost/indexed cost of acquisition.</p> <p>Treatment of Capital tax and applicable TDS to be clarified.</p> <p>Query-2</p> <p>Modality of transfer of assets to be defined.</p> <p>In case only assets to be transferred then application of stamp duty & other taxes and its treatment to be clarified.</p> <p>Query-3</p> <p>Modalities for O&M, other expenditure etc. for the transition period of 90 days may be confirmed.</p> <p>Availability calculation for the said period?</p> <p>Query-4</p> <p>There could be delay in receipt of payment against</p>			<p>free from any encumbrance and liability.</p> <p>Any taxes, stamp duties and liabilities, as may be applicable, has to be borne by the TSP.</p> <p>Query-3 and 6</p> <p>The transfer of all project assets along with substation land, right of way and clearances shall be completed at the end of 35 years from COD of the Project.</p> <p>All the expenditure till the transfer of all project assets along with substation land, right of way and clearances shall be borne by TSP.</p> <p>Query-4</p> <p>Definition of Project Assets is amply clear in this regard.</p>
--	---	--	--	--	---

		<p>respect of the Transmission System;"</p> <p>2.2.2 Post the Expiry Date of this Agreement, the TSP shall ensure transfer of Project Assets to STU or its successors or an agency as decided by the State Government at zero cost and free from any encumbrance and liability. The transfer shall be completed within 90 days of expiry of this Agreement failing which STU shall be entitled to take over the Project Assets Suo moto</p>	<p>receivables. Further, the TSP might have some pending claims against insurance company.</p> <p>How shall TSP receive these legitimate pending claim or charges after transfer of asset to STU?</p> <p>Query-5</p> <p>Please confirm that any taxes or charges or cost to be borne by the TSP at the transfer time including sale at value lower than fair value shall be reimbursed to the TSP.</p> <p>These costs are not known at this point of time and might be significant in amount. TSP cannot be exposed such charges.</p> <p>Query-6</p> <p>Modalities for O&M, other expenditure etc. for the transition period of 90 days may be confirmed.</p>			
<p>36.</p>	<p>RFP</p>	<p>Clause 2.7.2</p>	<p>The important timelines are mentioned in the table including shortlisting and announcement of Qualified bidder, proposed date of</p>		<p>For clarity and to comply with SBD requirement</p>	<p>The qualification status is being informed to the bidders invariably. Further, all relevant dates are informed to the</p>

			<p>issuance of LoI, transfer of SPV etc.</p> <p>It is observed in the past that in case, there is extension in bid submission date, the revised timelines are not being provided regarding issuance of LoI, transfer of SPV etc.</p> <p>Further, in case of delay in shortlisting of qualified bidders, it is requested to provide the updated dates of financial bid opening and date of conduction of e-RA etc., atleast 1 week prior to financial bid opening, to enable bidders to take appropriate action for participation in e-RA</p> <p>It is requested to kindly provide the updated table in case of extension in bid submission date/ delay in shortlisting of qualified bidders.</p>			<p>bidders, as per provisions of RFP.</p>
37.	RFP	<p>2.15.3 After the date of acquisition of the equity shareholding of SPV [which is under incorporation], along with all its related assets and liabilities, by the Selected Bidder,</p> <p>i. the authority of the BPC in respect of this Bid Process shall forthwith cease and any actions to be taken thereafter</p>	<p>Role of BPC has to be complete.</p>		<p>The BPC shall not relinquish its role after the acquisition but shall have to undertake all activities including</p>	<p>The role of BPC is as per the SBD and hence no change envisaged.</p> <p>However, it may be noted that the BPC shall fulfil its responsibility of providing the certification from the Bid Evaluation Committee</p>

		will be undertaken by the Nodal Agency,			providing the certification from the Bid Evaluation Committee etc., and other requirements to enable the Bidder to obtain Transmission license and adoption of Transmission charges. Furthermore, any activity which has an origin traced to the BPC activity/process has to be owned by BPC and the TSP / LTTC is neither aware nor can be made responsible.	to enable the TSP to obtain Transmission license and adoption of Transmission charges. The details of the contractual obligations (if any) of BPC to be fulfilled by the TSP shall be provided to the bidders along with the tentative Acquisition price of SPV.
38.	RFP	2.15.3 iv. contractual obligations undertaken by the BPC shall continue to be fulfilled by the TSP.	What are the obligations that the BPC has undertaken which needs to be fulfilled by the TSP?		Nature of contractual obligations cannot be left open as the same is to be fulfilled by the TSP.	The details of the contractual obligations (if any) of BPC to be fulfilled by the TSP shall be provided to the bidders along with the tentative Acquisition price of SPV.

39.	RFP & TSA	<p>Provision of RFP</p> <p>2.15.4</p> <p>Within five (5) working days of the issue of the acquisition of the SPV by the Successful Bidder, the TSP shall apply to the Commission for grant of Transmission License and make an application to the Commission for the adoption of Transmission Charges, as required under Section - 63 of The Electricity Act 2003</p> <p>Provision of TSA</p> <p>3.1.1.....The TSP shall, within five (5) working days from the date of acquisition of SPV by the Selected Bidder, undertake to apply to the Commission for the grant of Transmission License and for the adoption of tariff as required under section-63 of the Electricity Act</p>	<p>Query-1</p> <p>We request you to consider at least 30 days' time for completion of these activities.</p> <p>Query-2</p> <p>Definition of working day is not defined in the TSA. Therefore, it is requested to define working day to avoid ambiguity and litigation later on</p>	<p>Within thirty (30) working days of the issue of the acquisition of the SPV by the Successful Bidder, the TSP shall apply to the Commission for grant of Transmission License and make an application to the Commission for the adoption of Transmission Charges, as required under Section - 63 of The Electricity Act 2003</p>		<p>Query-1</p> <p>This is as per the SBD and amendments thereof, issued by the Ministry of Power and hence, no change is envisaged.</p> <p>Query-2</p> <p>For this purpose, working day shall mean a day on which the office of the Central Commission i.e. CERC is functioning.</p>
40.	RFP	<p>2.15.6 If the TSP fails to obtain the Transmission License from the Commission, it will constitute sufficient grounds for-annulment of award of the Project</p>	<p>In case TSP fails to obtain the Transmission License the reasons for the same have to be examined.</p>	<p>2.15.6 If the TSP fails to obtain the Transmission License from the Appropriate Commission, the treatment shall be as per</p>	<p>Provisions of 3.3 of TSA provides for consequences for non-fulfilment of conditions subsequent. The provisions of RFP as such</p>	<p>This is as per the SBD and amendments thereof, issued by the Ministry of Power and hence, no change is envisaged.</p>

				provisions 3.3 of the TSA.	have to be reflective of TSA.	
41.	RFP and TSA	<p>The definition of Contract Year in RFP is as under:</p> <p>"Contract Year" shall mean the period beginning on the Scheduled COD, and ending on the immediately succeeding March 31 and thereafter each period of 12 ...:</p> <p>And the definition of Contract Year in TSA is as under:</p> <p>"Contract Year", for the purpose of payment of Transmission Charges, shall mean the period beginning on the COD, and ending on the immediately ..."</p>	<p>As per RFP, the Contract Year shall start from the Scheduled CoD whereas as per TSA, the Contract Year shall start the CoD. As such, both the definitions are contradictory in nature.</p> <p>It is requested to clarify the correct definition of Contract Year.</p>		To avoid ambiguity	The provisions of TSA are amply clear in this regard and shall prevail.
42.	TSA	<p>Clause no 2.3: Conditions prior to the expiry of the Transmission License</p> <p>2.3.1 In order to continue the Project beyond the expiry of the Transmission License, the TSP shall be obligated to make an application to the Commission at least two (2) years before the date of expiry of the Transmission License, seeking the Commission's approval for the extension of the term of the Transmission License up to the Expiry Date.</p> <p>2.3.2 The TSP shall timely comply with all the requirements that may be laid down by the Commission for extension of the term of the Transmission License</p>	<p>There should be a provision in the TSA to cover the revenue loss that may be incurred by the TSP, in the case of the Appropriate Commission not granting extension of the Transmission License beyond the period of 25 years.</p>		The Transmission Charges to be quoted by the bidders would be based on the cash flow generated from the Project for 35 years and if, for any reason not attributable to the TSP (including any change in	<p>This is as per the SBD and amendments thereof, issued by the Ministry of Power.</p> <p>Please also refer Article 4.1 (a) of the TSA.</p>

		beyond the initial term of twenty-five (25) years & upto the Expiry Date and the TSP shall keep the Nodal Agency fully informed about the progress on its application for extension of the term of the Transmission License.			law), the Transmission License is not extended by the Appropriate Commission beyond 25 years the TSP will suffer significant losses. The RFP / TSA should be suitably modified to provide security of continuation of the transmission business for at least 35 years.	
43.		3.1.3 The TSP agrees and undertakes to duly perform and complete the following activities within six (6) months from the Effective Date (except for c) below), c) To submit to the Nodal Agency, CEA & Independent Engineer, the Project Execution Plan, immediately after award of contract(s) and maximum	As per clause 3.1.3 h, the EPC contracts to be awarded in 6 months. Whereas as per clause 3.1.3 c, TSP is required to submit Project Execution Plan after awards of Contracts within 120 days. TSP shall not be in a position to submit project plan within 120 days from effective date if the award of EPC contract is		For clarity	This is as per the SBD and amendments thereof, issued by the Ministry of Power and hence, no change is envisaged.

	TSA	within one hundred and twenty (120) days from the Effective Date. h) To award the Engineering, Procurement and Construction contract (“EPC contract”) for the design and construction of the Project and shall have given to such Contractor an irrevocable notice to proceed;	awarded after 120 days, but before 6 months period. As such, the timelines mentioned in above clauses are contradictory and the same may be reviewed.			
44.	TSA	Clause 3.3.1: If any of the conditions specified in Article 3.1.3 is not duly fulfilled by the TSP even within three (3) Months..... in accordance with the provisions of this Agreement		Suggested text to be added at the end of this Article: “..... The additional Contract Performance Guarantee, if any provided by the TSP for delay in fulfilment of condition subsequent, shall be returned by the CTUIL on fulfilment of conditions subsequent by the TSP”	The additional CPG is for specific default(s) and once such default(s) cease to exist, this additional amount of CPG should be returned. Additional CPG cannot be held back by the CTUIL till COD of the Project.	This is as per the SBD and amendments thereof, issued by the Ministry of Power and hence, no change is envisaged.
45.	TSA	Clause no 3.3.4: In case of inability of the TSP to fulfil the conditions specified in Article 3.1.3 due to any Force Majeure Event, the time period for	The terms and conditions for termination of the TSA under this Article, including the termination payment and		In case the Force majeure event continues, the	This is as per the SBD and amendments thereof, issued by the Ministry of

		<p>fulfilment of the condition subsequent as mentioned in Article 3.1.3, may be extended for a period of such Force Majeure Event. Alternatively, if deemed necessary, this Agreement may be terminated by the Nodal Agency by giving a Termination Notice to the TSP, in writing, of at least seven (7) days, with a copy to CEA and the Lenders' Representative in order to enable the Lenders to exercise right of substitution in accordance with Article 15.3 of this Agreement and the Contract Performance Guarantee shall be returned as per the provisions of Article 6.5.1.</p> <p>.....</p>	<p>status of the SPV, need to be provided in the TSA.</p>		<p>TSA will be terminated and the CPG will be returned.</p> <p>Other expenses that would have been incurred till the date of termination of the TSA including the Acquisition Price paid for Acquiring the SPV and other incurred costs shall also be explicitly stated. There should be an explicit provision for refund of the Acquisition Price, along with the other expenses incurred by the TSP / Selected Bidder till such date of termination.</p>	<p>Power and hence, no change is envisaged.</p>
--	--	--	---	--	--	---

46.	TSA	<p>3.3.4</p> <p>.....</p> <p>Provided, that due to the provisions of this Article 3.3.4, If the Scheduled COD is extended beyond a period of one hundred eighty (180) days due to the provisions of this Article 3.3.4, the TSP will be allowed to recover the interest cost during construction corresponding to the period exceeding one hundred eighty (180) days by adjustment in the Transmission Charges in accordance with Schedule 9</p> <p>11.7 (e) Available Relief for a Force Majeure Event</p> <p>For avoidance of doubt, the TSP acknowledges that for extension of Scheduled COD a period up to one hundred eighty (180) days due to Force Majeure event, no compensation on the grounds such as interest cost,.....</p>	<p>In case project suffers from Force Majeure event for a period less than 6 months, interest cost during construction may be considered.</p>		<p>For project viability.</p>	<p>This is as per the SBD and amendments thereof, issued by the Ministry of Power and hence, no change is envisaged.</p>
47.	TSA	<p>4.6 Interconnection Facilities:</p> <p>4.6.1 Subject to the terms and conditions of this Agreement, the TSP shall be responsible for connecting the Project with the interconnection point(s) specified in Schedule 1 of this Agreement. The Interconnection Facilities shall be developed as per the scope of work and responsibilities assigned in Schedule 1 of this Agreement. The Nodal Agency shall be</p>	<p>It is understood that if interconnection facilities at the interconnection point is not available, whereas TSP has completed rest of the scope of the project, the project shall be considered as deemed COD and TSP shall be entitled to all the benefits envisaged under the TSA.</p>		<p>For clarity.</p>	<p>The provisions of TSA are amply clear in this regard & shall prevail.</p>

		<p>responsible for coordinating to make available the Interconnection Facilities.</p> <p>4.6.2 In order to remove any doubts, it is made clear that the obligation of the TSP within the scope of the project is to construct the Project as per Schedule-1 of this Agreement and in particular to connect it to the Interconnection Facilities as specified in this Agreement.</p>				
48.	TSA	<p>6.1 Connection with the Inter-connection Facilities:</p> <p>6.1.1 The TSP shall give the RLDC(s), CTU, / STU, as the case may be, and any other agencies as required, at least sixty (60) days advance written notice of the date on which it intends to connect an Element of the Project, which date shall not be earlier than its Scheduled COD or Schedule COD extended as per Article 4.4.1 & 4.4.2 of this Agreement, unless mutually agreed to by Parties. Further, any preponing of COD of any element prior to Scheduled COD must be approved by the Nodal Agency.</p> <p>6.2.1 An Element of the Project shall be declared to have achieved COD twenty four (24) hours following the connection of the Element with the Interconnection Facilities pursuant to Article 6.1 or seven (7) days after the date on which it is declared by the TSP to be ready for charging but is not able to be charged for reasons not</p>	<p>Reference is drawn to the Order of CERC 4/ADP/2016 dated 23.03.2016. Relevant extract of the Order is reproduced hereunder:</p> <p>“In the event the inter-connection facilities are not ready by SCOD or by revised SCOD (as may be revised by the petitioner and the LTTCs for the purpose of availing incentive as per MOP Policy) on account of non-readiness of the upstream or downstream transmission assets while the petitioner’s transmission system is ready for commissioning, the COD of the transmission assets of the petitioner may be declared in accordance with the provisions of Article 6.2 of the TSA (to be known as „deemed COD“) and the LTTCs/developers of the upstream and downstream</p>		Order of CERC 4/ADP/2016 dated 23.03.2016.	This shall be treated as per applicable CERC Regulations/ Orders/ TSA.

		<p>attributable to the TSP subject to Article 6.1.2.</p> <p>Provided that an Element shall be declared to have achieved COD only after all the Element(s), if any, which are pre-required to have achieved COD as defined in Schedule 2 of this Agreement, have been declared to have achieved their respective COD.</p> <p>6.2.2 Once any Element of the Project has been declared to have achieved deemed COD as per Article 6.2.1 above, such Element of the Project shall be deemed to have Availability equal to the Target Availability till the actual charging of the Element and to this extent, TSP shall be eligible for the Monthly Transmission Charges applicable for such Element.</p>	<p>assets shall be liable to pay the transmission charges from the deemed COD till the transmission assets are put into actual use.”</p> <p>From above, it is seen that even in case of SCOD when the systems are declared deemed COD as per Article 6.2 of TSA, till the transmission assets are put into actual use, the transmission charges are liable to be paid by DICs/developers of the upstream and downstream assets.</p> <p>In such situations, it shall be construed that BPC has obtained consent of the DICs/ Upstream / Downstream / Generators (as applicable) for payment of transmission charges.</p> <p>Further, as per CERC order no. 104/MP/2018 dated 18th September 2018, downstream was directed to pay transmission charges to TSP.</p>			
49.	TSA	<p>Clause 6.3.1 (b)</p> <p>In case of delay due to Indirect Non-Natural Force Majeure Event or Natural</p>	<p>Clause 6.3.1 (b) covers the loss on debt amount which includes, due to Indirect Non-Natural Force Majeure Event</p>			<p>This is as per the SBD and amendments thereof, issued by the Ministry of</p>

		Force Majeure Event affecting the Nodal Agency, TSP is entitled for payment for debt service which is due under the Financing Agreements, subject to a maximum of Transmission Charges calculated on Target Availability, for the period of such events in excess of three (3) continuous or non-continuous Months in the manner provided in (c) below.	or Natural Force Majeure Event affecting the Nodal Agency, TSP is entitled for payment for debt service which is due under the Financing Agreements. However, any loss on the equity is not covered in the above clause. In order to compensate for the loss due to Indirect Non-Natural Force Majeure Event or Natural Force Majeure Event affecting the Nodal Agency, compensation to both equity as well as debt to be covered as per clause 6.3.1 (a).			Power and hence, no change is envisaged.
50.	TSA	10 BILLING AND PAYMENT OF TRANSMISSION CHARGES 10.3 Rebate & Late Payment Surcharge	Any changes in CERC regulations, which have an implication on Billing cycle and/or cost implication to the TSP due to change in rebate and late payment surcharge, the same shall be allowed to be recovered under Change in law.			This is as per the SBD and amendments thereof, issued by the Ministry of Power and hence, no change is envisaged.
51.	TSA	Clause no. 10.1: Subject to provisions of this Article 10, the Monthly Transmission Charges shall be paid to the TSP, in Indian Rupees, on monthly basis as per the provisions of this agreement, from the date on which an Element(s) has achieved COD until the Expiry Date of this Agreement, unless terminated earlier and in line with the		Subject to provisions of this Article 10, the Monthly Transmission Charges shall be paid to the TSP, in Indian Rupees, on	As per clause 6.2 of the TSA, the TSP is eligible for payment of Transmission charges from the date of deemed COD.	This is as per the SBD and amendments thereof, issued by the Ministry of Power and hence, no change is envisaged.

		provisions of Schedule 4 of this Agreement.		monthly basis as per the provisions of the Sharing Regulations, from the date on which an Element(s) has achieved COD or deemed to have achieved COD until the Expiry Date of this Agreement, unless terminated earlier and in line with the provisions of Schedule 4 of this Agreement		
52.	TSA	11.4 Force Majeure Exclusions 11.4.1 (g) Any error or omission in the survey report provided by BPC during the bidding process.	The survey report furnished by BPC has to be accurate and any error or omission has to be owned by the BPC. Professional fees including fees for survey report is also claimed by BPC.			This is as per the SBD and amendments thereof, issued by the Ministry of Power and hence, no change is envisaged. Please also refer Clause 2.5.7 of RFP Document
53.	TSA Clause 12.1.1	Clause 12.1.1 Change in Law means the occurrence of any of the following after the Bid Deadline resulting into any additional	It is mentioned that in case any change in law event occurs on bid submission date or just prior to bid submission date, the bidders			This is as per the SBD and amendments thereof, issued by the Ministry of

		recurring / non-recurring expenditure by the TSP or any savings of the TSP....	shall not have adequate time to understand the cost implication of such change in law event. Bidders cannot be exposed to such uncertainties and thereafter it is requested to consider any event after 7 days prior to bid deadline as Change in Law event. Furthermore, the bid submission is fixed at 12 noon. Whereas change in event could happen during the day even after 12 noon. Such clause can have serious implications on the viability of the project.			Power and hence, no change is envisaged. Also, please refer to clause 2.5.7 of the RFP.
54.	TSA	12.1.2 Notwithstanding anything contained in this Agreement, Change in Law shall not cover any change: a. Taxes on corporate income; and; and Withholding tax on income or dividends distributed to the shareholders of the TSP.	Any tax applied on the income or profits of the TSP need to be covered under change in law.		Tax is an element beyond the control of the TSP. Change in tax or introduction of any tax is covered under change in law. Tax rate applicable on the income or profits of the TSP is beyond the control of	This is as per the SBD and amendments thereof, issued by the Ministry of Power and hence, no change is envisaged. Also, please refer to clause 2.5.7 of the RFP.

					the TSP and to assume the same for 35 years shall be a risk which is best assumed by the LTTCs accordingly this is to be reviewed.	
55.	TSA	<p>Clause 13.7</p> <p>If Agreement is terminated on account of Force Majeure Events, nonrequirement of any Element or Project during Construction, Nodal Agency's non-fulfilment of Role & TSP's Event of Default, the TSP shall be entitled for Termination Payment equivalent to valuation of Project Assets. Upon payment, the Nodal Agency shall take over the Project Assets</p>	Kindly furnish the methodology of calculation of valuation of project asset.		For clarity	Valuation of project assets shall be done as per the prevailing industry practices. Further, please refer Clause 18.2 e) of TSA.
56.	TSA	<p>Clause 10.1.2.1</p> <p>10.1.2.1 Any amount payable under an Invoice shall be paid in immediately available and freely transferable clear funds, for value on or before the Due Date, to such account of the TSP or Long Term Transmission Customer as shall have been previously notified to Long Term Transmission Customer or the TSP, as the case may be</p> <p>10.3 Rebate & Late Payment Surcharge:</p>	<p>Timelines for payment of transmission charges is linked to "due date". However, the "due date" is not defined in the TSA.</p> <p>It is requested to provide the definition of "due date" to avoid confusion and litigation.</p>		For clarity	This is as per the SBD and amendments thereof, issued by the Ministry of Power and hence, no change is envisaged.

		<p>10.3.1 Rebate: In case the Long Term Transmission Customer pays to the TSP through any mode of payment in respect of a Monthly Transmission Charge Invoice or Supplementary Bill, the following shall apply:</p> <p>a. For payment of Invoices through any mode of payment, a Rebate of 2% shall be allowed on the Monthly Transmission Charge Invoice or Supplementary Bill for payments made in full within two Business Day of the receipt of the Invoice; or</p> <p>b. For payment of Invoices subsequently, but within the Due Date, a Rebate of 1% shall be allowed on the payments made in full.</p> <p>and</p> <p>others</p>				
57.	RFP	<p>Clause 2.1.2</p> <p>“Experience of development of projects in the Infrastructure Sector in the last five (5) years with aggregate capital expenditure of not less than Rs..... Crore or equivalent USD (calculated as per provisions in Clause 3.4.1). However, the capital expenditure of each project shall not be less than Rs..... Crore or equivalent USD</p>	<p>As per QR, the capital expenditure under reference shall be as capitalised and reflected in the audited books of accounts of Technically Evaluated Entity.</p> <p>In above regard, please clarify the following:</p> <p>Whether entire capital expenditure of various Project(s), meeting the value-</p>		<p>For more clarity for submission of appropriate QR credentials</p>	<p>Provisions of RFP Document are amply clear in this regard and shall prevail.</p>

		<p>(calculated as per provisions in Clause 3.4.1</p> <p>For this purpose, capital expenditure incurred on projects that have been commissioned/ completed at least seven (7) days prior to Bid Deadline shall be considered. The capital expenditure discussed above shall be as capitalized and reflected in the audited books of accounts of the Technically Evaluated Entity.....”.</p>	<p>wise threshold requirements of QR, as capitalised in last five years in the audited books of accounts of Technically Evaluated Entity, shall be considered;</p> <p>OR</p> <p>Whether only the capital expenditure incurred in the last five years of such Project(s), capitalised in last five years in the audited books of accounts of Technically Evaluated Entity, shall be considered.</p>			
58.	RFP	<p>Clause 2.11</p> <p>Each Bidder shall submit the Bid accompanied by Bid Bond issued by any of the Banks listed in Annexure-17. The Bid Bond shall be valid for a period of thirty (30) days beyond the validity of the Bid.</p>	<p>Verification of issued bid bond is done by the beneficiary bank of the BPC through SFMS platform from the issuing bank of the bidder.</p> <p>In above regard, BPC is requested to provide following details.</p> <ul style="list-style-type: none"> - Bank account detail of beneficiary alongwith IFSC code and Branch address <p>Unique Identifier of the beneficiary (if applicable) (The unique identifier needs to be incorporated by the issuing bank in Field 7037 of</p>		<p>Bidder needs information for issuance of Bid Bond</p>	<p>Requisite details have already been provided in the RFP document.</p>

			the IFIN 760 COV/IFIN COV while transmitting verification messages to the Beneficiary Bank through SFMS).			
59.	RFP	<p>Annexure 14 (Format of the Bid Bond)</p> <p>Addressee details are not mentioned in the beginning of the format</p> <hr/> <p>Annexure 14 (Format of the Bid Bond)</p> <p>“.... In consideration of the.....”</p>	<p>Addressee details to whom Bid Bond is to be addressed are not mentioned in the Bid Bond Format. It is requested to mention the followings at starting of the format:</p> <hr/> <p>Annexure 14 (Format of the Bid Bond)</p> <p><i>“ To,</i></p> <p><i>Designation of officer</i></p> <p><i>Name of BPC</i></p> <p><i>Address of BPC</i></p> <p>In consideration of the.....”</p>			<p>This is as per the SBD and amendments thereof, issued by the Ministry of Power and hence, no change is envisaged.</p>
60.	RFP	<p>Clause 1.6.2.2 –</p> <p>The details and documents as may be obtained by the BPC/ project specific SPV in relation to the Project shall be handed over to the TSP on an as-is-where-is basis, so that it may take further actions to obtain Consents, Clearances and Permits</p>	<p>BPC to get the GST registration and GST TAN registration in the name of SPV in the State of Project execution where supply of Goods and Services shall take place.</p>		<p>For immediate commencement of execution of work by the SPV upon acquisition by</p>	<p>BPC will complete its responsibilities as listed in the RFP documents. Please also refer Clause 1.6 & 2.5.7 of the RFP document.</p>

					the successful bidder.	
61.	SPA	<p>Clause 1.2 (i)</p> <p>“Acquisition Price” shall mean INR _____ (Rupees _____ only) [Insert the value of the Acquisition Price, both in figures and in words respectively], which is the aggregate consideration payable by the Selected Bidder towards purchase of the Sale Shares at par along with assets and liabilities of the Company as on the Closing Date subject to adjustment as per the audited accounts of the Company as on the Closing Date;</p>	<p>As per clause 1.2 (i) of the Share Purchase agreement, BPC is required to provide audited financial statement as on the closing date for adjustment, if any, in regard to aggregate consideration for acquisition of the SPV.</p> <p>It is requested to BPC to furnish audited financial statement within 15 days of the closing date.</p>		<p>Audited financial statement is required for accounting in the books of successful bidder to ascertain acquisition price on closing date. An undertaking that the audited financial statements shall be provided within 15 days from the closing date may be furnished by BPC for making the payment of acquisition price by successful bidder.</p>	Provisions of SPA shall prevail.
62.	ANNEXURE 3 - FORMAT FOR	<p>...Know all men by these presents, We</p> <p>.....(name</p>	As per the format of Power of Attorney, the bidder is required to mention the		For clarity and simplification	PoA will be given on stamp paper of the State where the person is executing it and getting it

	EVIDENCE OF AUTHORIZED SIGNATORY'S AUTHORITY	and address of the registered office of the Bidder...	name and registered office of the bidder. In case corporate office of the bidder is in different state than that of its registered office, can the bidder execute the Power of Attorney in the state of its corporate office?		of bidding process	notarised. Since corporate office is generally the functional office of the company, Bidder can execute the PoA in the state of its corporate office if that is the seat of the Principal executing the PoA.
63.	Clause No. 2.5, Section - II of RFP Documents	2.5 The Bidding Process The initial period for conducting the e-reverse bidding should be 2 hours which will be extended by 30 minutes from the last received bid time, if the bid is received during the last 30 minutes of the scheduled or extended bid time. Subsequently, it will be extended again by 30 minutes from the latest received bid time. 		2.5 The Bidding Process The initial period for conducting the e-reverse bidding should be 2 hours which will be extended by 15 minutes from the last received bid time, if the bid is received during the last 15minutes of the scheduled or extended bid time. Subsequently, it will be extended again by 15	As per revised Standard Bidding Documents, the bidders are required to quote single annual Transmission Charge from the date of SCOD of the project till expiry date in initial bid and in the e-RA. During e-RA, the initial time period for e-RA is 2 hours with extension of 30 minutes from last bid. In this regard, it is submitted that the bidder is	This is as per the SBD and amendments thereof, issued by the Ministry of Power.

			<p>minutes from the latest received bid time.</p> <p>In case e-Reverse Bidding is not completed by 20:00 Hrs (IST), then the e-Reverse Bidding shall be paused and will resume on the next working day at 10:00 Hrs (IST). The prevailing L1 bidder at the time of pause on the previous day shall continue to be the L1 bidder at resumption of e-Reverse Auction. On resuming, the e-Reverse Bidding shall</p>	<p>required to quote single number as annual transmission charges.</p> <p>Further, there is option for automatic reduction in e-RA portal. Therefore, the extension of 30 minutes from last bid submission may be reduced to 15 minutes.</p> <p>Further, in case the bidding extends beyond office hours, the e-RA may be paused and resumed on the next working day as being followed by major eps providers including Mjunction etc.</p>	
--	--	--	--	--	--

				<p>conducted for 60 minutes, which will be extended by 15 minutes from the last received bid time, if the bid is received during the last 15minutes. Subsequently, it will be extended again by 15 minutes from the latest received bid time.</p> <p>The above shall continue till the e-Reverse Bidding gets concluded.</p> <p>....</p>		
64.	TSA: Clause 5.5.6	For any delay in commissioning any critical Element(s), as identified in Schedule 1 & Schedule 2 of this Agreement, beyond a period of 45 days	As a general practice, the CERC considers any request for extension of time post COD of the Project. BPC to clarify that whether the 10%		Bidder needs the information for proper estimation	This is as per the SBD and amendments thereof, issued by the Ministry of

		shall lead to a sequestration of 10% of the Contract Performance Guarantee.	of CPBG will be invoked even when such delay is caused due to FM events and without adjudication on the validity of such claims?			Power and hence, no change is envisaged.
65.	TSA: Clauses 4.1(f) and 4.2.1(e)	These clauses provide assistance by Nodal Agency or TSP to the Arbitrators as required for the performance of their duties and responsibilities.	BPC to provide the definition of Arbitrators used as defined term.		Bidder needs the information for proper estimation	This is as per the SBD and amendments thereof, issued by the Ministry of Power.
66.	RFP	RFP, section-1, Clause 1.5, Para 3 “The TSP shall ensure transfer of all project assets along with substation land, right of way and clearances to STU or its successors or an agency as decided by the State Government after 35 years from COD of project at zero cost and free from any encumbrance and liability. The transfer shall be completed within 90 days after 35 years from COD of project failing which STU shall be entitled to take over the project assets Suo moto”.	1) Please note that there is no clarity about the liability of the TSP post Transfer of asset. We request BPC to define the process of Transfer. 2) As the project is BOOT basis, we request BPC to provide Transfer Agreement for bidder’s review and assessment. 3) As the project is BOOT basis, what will be the Liability of TSP in case of any Default post Transfer to STU. 4) As per the RFP, the transfer shall be completed within 90 days after 35 years from COD of project failing which STU shall be entitled to take over the project assets Suo moto. We request BPC to confirm		Bidder needs the information for proper estimation.	1. The project assets along with substation land, right of way and clearances shall be transferred to nodal agency or its successors or an agency as decided by the Central Government after 35 years from COD of project at zero cost and free from any encumbrance and liability and no elaborate process is required to be laid down. Further, other issues, if any, shall be dealt as per prevailing laws & regulations. 2. Transfer Agreement, if required, may be mutually agreed between the parties at that point of time. 3. In case there is any liability due to an event that has occurred post transfer to CTU, the same

			<p>whether the Project is required to be given on as is where is basis or if STU can ask for certain refurbishments to be done?</p> <p>It is requested to BPC to confirm will there be an obligation of the TSP to obtain re obtain the clearance at the time of Transfer, in case of NHAI, Road, Highways etc.</p>		<p>shall be dealt with as per prevailing laws & regulations</p> <p>4. The project assets will be transferred in working condition subject to observations of Nodal agency in the examination to be carried out three (3) years prior to the expiry of the project to assess the need of upgradation of the system or renovation and modernization of the existing system.</p> <p>5. Please refer to the definition of "Project Assets" in this regard which is amply clear and shall prevail.</p>
67.	RFP	<p>RFP, Clause 1.6. Clause no. 1.6.1.5 – Scope of Transmission Service Provider</p> <p>The TSP shall seek approval under Section 164 of Electricity Act, from CEA after acquisition of SPV [which is under incorporation]. The approval shall be granted by CEA generally within 30 days but in no case later than 45 days from the date of receipt of application (complete in all aspects).</p>	<p>We request BPC to confirm that in case of delay in grant of section 164 approval beyond 45 days by CEA, will this qualify as Force Majeure (FM) event under TSA, and we can get relief as per TSA.</p>	<p>Bidder needs the information for proper estimation.</p>	<p>This is as per the SBD and amendments thereof, issued by the Ministry of Power. The provisions of RFP shall prevail.</p>
68.	RFP	<p>Request for Proposal Notification, Disclaimer</p>	<p>We would like to mention that it will be unreasonable on part of BPC to reject a bid without assigning any</p>	<p>Bidder needs the information</p>	<p>This is as per the SBD and amendments thereof, issued by the Ministry of</p>

		This RFP may be withdrawn or cancelled by the BPC at any time without assigning any reasons thereof. BPC further reserves the right, at its complete discretion to reject any or all of the Bids without assigning any reasons whatsoever.”	reason. Since the BPC can be construed as ‘state’ under the Constitution, conduct of BPC ought to have transparent and as such BPC cannot take any decision without assigning proper reason/justification.		for proper estimation.	Power. The provisions of RFP shall prevail.
69.	RFP	Definition: Conflict of Interest” A Bidder shall be considered to be in a Conflict of Interest with one or more Bidders in the same bidding process if they have a relationship with each other, directly or through a common company, that puts them in a position to have access to information about or influence the Bid of another Bidder	It needs to be noted that this definition is vague and wide in as much as it only requires that an entity is able to have access; it is immaterial whether information was accessed or not, just the fact that a party is in a position to access information or influence bid of another party is enough. As far as this aspect is concerned, this definition should be amended. This should further cover any conflict-of-interest situation between the BPC and any of the bidder		Bidder needs the information for proper estimation.	This is as per the SBD and amendments thereof, issued by the Ministry of Power and hence, no change is envisaged.
70.	RFP	Pre Award Integrity Pact: Clause 3.3 provides that “the Bidder shall disclose the name and address of agents and representatives and Indian Bidder shall disclose their foreign principals or associates”. Clause 3.4 states that “the Bidder shall disclose the payments to be made by them to agents/brokers or any other	BPC is requested to clarify the rationale for having this clause? We understand that The Bidder is free to engage any consultant as long as it is under the purview of applicable law.		Bidder needs the information for proper estimation	This is as per the SBD and amendments thereof, issued by the Ministry of Power. The provisions of RFP shall prevail.

		intermediary, in connection with this bid”.				
71.	RFP	ANNEXURE 22 - FORMAT FOR AFFIDAVIT	<p>We would like to mention that with reference to the RFP Clause 2.1.9 Bidders shall confirm a notarized affidavit as per Annexure 22.</p> <p>Please note for large conglomerates signing on behalf of all the affiliates can run into hundreds of numbers and different geographies, is practically impossible.</p> <p>We request you to allow Annexure-22 to be signed by the Authorized signatory of the Bidding company on behalf of Bidding entity only.</p>		Bidder needs the information for proper estimation	The declaration and details with respect to Clause 2.1.9 of RFP is to be provided by the bidding company including Affiliate / Parent company of the Bidding company being used for meeting financial / technical qualification requirements as per Annexure 22 of the RFP document. The signing of the format has to be done as per provisions of RFP Document.
72.	RFP	<p>Definitions:</p> <p>Transmission Service Agreement” or “TSA” shall mean the agreement entered into between Nodal Agency and the TSP, pursuant to which the TSP shall build, own, operate and transfer the Project and make available the assets of the Project on a commercial basis.</p>	As per the bidding documents TSA shall be signed between Nodal agency and TSP only. We request BPC to clarify role of Designated ISTS Customers and linkage of Designated ISTS Customers to TSA.		Bidder needs the information for proper estimation	Please refer Clause 2.5.7 of RFP.
73.	RFP/ Annexure no. 15- format for Contract Performan	<p>Annexure no. 15- format for Contract Performance Guarantee/ Last Para</p> <p>Notwithstanding anything (365) days thereafter. This BANK GUARANTEE shall be extended from time to time for such period, as may be</p>	<p>Kindly note that the Government banks are not issuing the contract Performance Guarantee.</p> <p>We request BPC to modify the last Para of the Performance</p>		Bidder needs the information for proper estimation	This is as per the SBD and amendments thereof, issued by the Ministry of Power. No change is envisaged.

	ce Guarantee	desired by..... [Insert name of the Selected Bidder or Lead Member in case of the Consortium or SPV].	Guarantee format as highlighted in red font below: Notwithstanding anything (365) days thereafter. This BANK GUARANTEE shall may be extended from time to time for such period, as may be desired by..... [Insert name of the Selected Bidder or Lead Member in case of the Consortium or SPV and [Insert name of the Bank].			
74.	TSA	TSA: Clause H The billing, collection, and disbursement of the Transmission Charges by the CTU to the ISTS Licensee shall be governed as per Sharing Regulations.	In case of the default in the payment by the DIC, BPC is requested to clarify following a) How will the Transmission charges be recovered? b) what is the assurance for recovery of Transmission charges in view of the repeal of the Regulation of the power supply 2010 by the CERC.		Bidder needs the information for proper estimation	The payment of Transmission Charges by the CTU to the ISTS Licensee shall be governed as per CERC Sharing Regulations, as amended from time to time.
75.	TSA	TSA ARTICLE: 1 Definitions and Interpretations Independent Engineer” shall mean an agency/ company, appointed by Nodal Agency in accordance with the Guidelines for Encouraging	We understand that as the Independent Engineer to be appointed by Nodal Agency (CTU), the fee and charges of the Independent Engineer shall be paid by CTU and TSP does not have to consider any fee and charges of the Independent Engineer in its bid.		Bidder needs the information for proper estimation	Provisions of the TSA are amply clear in this regard and shall prevail.

		<p>Competition in Development of Transmission Projects</p> <p>TSA ARTICLE: 18</p> <p>18.3 Remuneration of Independent Engineer</p>				
76.	TSA	<p>TSA ARTICLE: 1</p> <p>Definitions and Interpretations</p> <p>Definition of Nodal Agency</p> <p>Nodal Agency” shall mean CTU, which shall execute and implement the Transmission Service Agreement (TSA);</p>	<p>The provision to the definition states that while taking major decisions, CTU shall consult CEA on technical matters and any other matter if it feels necessary.</p> <p>BPC is requested to provide clarity on what would constitute ‘major decisions’; further, what would be the nature of consultation is not clear, whether such consultation would be binding or just advisory in nature? Further, there is an element of discretion as well on the part of CTU, which should be done away with.</p>		<p>Bidder needs the information for proper estimation</p>	<p>Provisions of the TSA are amply clear in this regard and shall prevail.</p>
77.	TSA	<p>As per TSA,</p> <ol style="list-style-type: none"> 1. Scheduled COD for the Project: 18 Months from Effective Date. 2. Scheduled COD of each transmission Element: 18 months from the date of SPV Transfer 3. The Definition of Month: 	<p>BPC to confirm the following:</p> <ol style="list-style-type: none"> a. The Schedule COD for the Project is 18 Months from Effective Date and since the Month is used as defined term, therefore, the 18 Month for the Project will be calculated based on 30 days in each month? For example: If the Effective Date is 01-05- 		<p>Bidder needs the information for proper estimation</p>	<p>Provisions of TSA are amply clear in this regard and shall prevail.</p>

		<p>“Month” shall mean a period of thirty (30) days from (and excluding) the date of the event;</p>	<p>2023 then SCOD will be 22-10-2024.</p> <p>b. The Schedule COD for each transmission Element is 18 months from SPV transfer and month has not been used as defined term, therefore 18 months will be calculated on the month to month basis?</p> <p>For example: If the SPV transfer date is 01-05-2023 then SCOD will be 30-11-2024.</p> <p>c. BPC to clarify that the SCOD for each transmission Element is different from SCOD of the Project?</p>			
78.	<p>RFP for Selection of Bidder as Transmission Service Provider</p> <p>&</p> <p>TSA</p>	<p>Section-2, clause no. 2.6.</p> <p>Project Schedule</p> <p>Percentage of Quoted Transmission Charges recoverable on Scheduled COD of the Element of the Project</p> <p>& TSA: Schedule-4 Computation of Transmission Charges</p>	<p>Please note that there are 3 nos. of Transmission elements in the subject project. We understand that all elements of the scheme are required to be commissioned simultaneously as their utilization is dependent on each other and hence considering the same percentage of quoted transmission charges are clubbed and mentioned as single percentage (100%) for all these elements.</p>		<p>Bidder needs the information for proper estimation</p>	<p>Provisions of TSA are amply clear in this regard and shall prevail.</p>

			<p>BPC will appreciate that during Operation of the asset, if any outages happen to any element/ elements of said asset or any scenarios occurs which are illustrated in schedule-4 of TSA then it will be difficult to compute payment of Transmission Charges under various scenarios based on the availability of each element.</p> <p>In view of the above, BPC is requested to provide break-up of each element.</p>			
79.	Transmission Service Agreement	<p>TSA ARTICLE: 6</p> <p>Clause no. 6.1.1</p> <p>The TSP shall give the RLDC(s), CTU, / STU, as the case may be, and any other agencies as required, at least sixty (60) days advance written notice of the date on which it intends to connect an Element of the Project, which date shall not be earlier than its Scheduled COD or Schedule COD extended as per Article 4.4.1 & 4.4.2 of this Agreement, unless mutually agreed to by Parties. Further, any preponing of COD of any element prior to Scheduled COD must be approved by the Long Term Transmission Customers.</p>	<p>BPC is requested to clarify in case of preponement of COD, whether the agreement will be effective for a period of 35 years from the date of such COD, or will there be extra period that will be granted to TSP as an incentive for declaring the commissioning earlier than the SCOD?</p>		<p>Bidder needs the information for proper estimation.</p>	<p>Provisions of TSA are amply clear in this regard and shall prevail.</p>
80.	Transmission Service Agreement	<p>TSA ARTICLE: 11</p> <p>Clause no. 11.4.1</p>	<p>We request BPC to remove the point no g from the Force Majeure Exclusions.</p>		<p>Bidder needs the information</p>	<p>This is as per the SBD and amendments thereof, issued by the Ministry of</p>

	 (g) Any error or omission in the survey report provided by BPC during the bidding process			for proper estimation.	Power and hence, no change is envisaged.
81.	Transmission Service Agreement	TSA ARTICLE: 13 Clause no.13.7 Termination Payment - If Agreement is terminated on account of Force Majeure Events, nonrequirement of any Element or Project during Construction, Long Term Transmission Customer's non-fulfilment of Role & TSP's Event of Default, the TSP shall be entitled for Termination Payment equivalent to valuation of Project Assets. Upon payment, the Long Term Transmission Customers shall take over the Project Assets.	As there is no mechanism for termination payment. We request BPC to provide the mechanism for compensating the cost incurred by the TSP for construction of asset, in case of non-requirement of any element during construction stage.		Bidder needs the information for proper estimation.	Valuation of project assets shall be done as per the prevailing industry practices. Further, please refer Clause 18.2 e) of TSA.
82.	Transmission Service Agreement	TSA ARTICLE: 3 Clause No. 3.3.4 Provided, that due to the provisions of this Article 3.3.4, any increase in the time period for completion of conditions subsequent mentioned under Article 3.1.3, shall lead to an equal increase in the time period for the Scheduled COD. If the Scheduled COD is extended beyond a period of one hundred eighty (180) days due to the	What is the rationale for only IDC recovery and no other expenditure like project cost overrun (such as overheads & price variation etc.)		Bidder needs the information for billing purpose.	This is as per the SBD and amendments thereof, issued by the Ministry of Power and hence, no change is envisaged.

		provisions of this Article 3.3.4, the TSP will be allowed to recover the interest cost during construction corresponding to the period exceeding one hundred eighty (180) days by adjustment in the Transmission Charges in accordance with Schedule 9.				
83.	Transmission Service Agreement	<p>TSA ARTICLE: 8</p> <p>8.2 Target availability</p> <p>The Target Availability of each Element and the Project shall be 98%.</p>	As per previous TSA, target availability was at project level not for each element. We request BPC to maintain target availability at Project level only.		Bidder needs the information for proper estimation.	This is as per the SBD and amendments thereof, issued by the Ministry of Power and hence, no change is envisaged.
84.	Transmission Service Agreement	<p>TSA ARTICLE: 12</p> <p>Relief for change in law 12.2.3 -</p> <p>12.2.3 For any claims made under Articles 12.2.1 and 12.2.2 above, the TSP shall provide to the Long Term Transmission Customers documentary proof of such increase / decrease in cost of the Project / revenue for establishing the impact of such Change in Law.</p>	Please note that No timelines defined for response by LTTC in case of CIL event. We request BPC to define timeline in which LTTC will respond to the TSP.		Bidder needs the information for proper estimation.	This is as per the SBD and amendments thereof, issued by the Ministry of Power and hence, no change is envisaged.
85.	Transmission Service Agreement	<p>TSA ARTICLE: 12</p> <p>Payment on account of Change in Law 12.4.1</p> <p>The payment for Change in Law shall be through a separate Bill. However, in case of any change in Monthly Transmission Charges by reason of Change in Law, as determined in accordance with this Agreement, the Bills to be raised by the Long Term</p>	BPC is requested to provide the format and timeline for submission of sperate bill of separate bill for settlement of CIL events?		Bidder needs the information for proper estimation.	The provisions of TSA are amply clear in this regard.

		Transmission Customers after such change in Transmission Charges shall appropriately reflect the changed Monthly Transmission Charges.				
86.	Transmission Service Agreement	<p>Schedule 2</p> <p>The payment of Transmission Charges for any Element, irrespective of its successful commissioning on or before its Scheduled COD, shall only be considered after successful commissioning of the Element(s), which are prerequired for declaring the commercial operation of such Element as mentioned in the above table.</p>	BPC is requested to clarify that in case an element is successfully commissioned and is put to use/power flows, but the pre-required element is not successfully commissioned. Will TSP be eligible for getting Tariff?		Bidder needs the information for proper estimation.	The provisions of TSA are amply clear in this regard and shall prevail.
87.	Transmission Service Agreement	<p>Schedule 9</p> <p>Methodology for determining the Relief Under Force Majeure Event & Change in Law during Construction Period</p> <p>The relief in the form of revision in tariff due to Force Majeure Event leading to extension of Scheduled COD for a period beyond one hundred eighty (180) days and/ or Change in Law during the construction period shall be as under: $\Delta T = [(P \times d)] \div [1 - (1 + d)^{-n}]$</p>	What is the rationale for the increase in Transmission Charges as stated above shall be applicable only if the value of increase in Transmission Charges as calculated above exceeds 0.30% (zero-point three percent) of the quoted Transmission Charges of the TSP.		Bidder needs the information for proper estimation.	This is as per the SBD and amendments thereof, issued by the Ministry of Power.
88.	TSA	<p>Schedule: 9</p> <p>Methodology for determining the Relief Under Force Majeure Event & Change in Law during Construction Period</p>	CERC notified 'Discount rate for computation of levelized transmission charges' is 8.09% on 30th March, 2022, please confirm if this Discount rate for computation of levelized transmission charges is to be considered for this		Bidder needs information for proper estimation.	Provisions of TSA are amply clear in this regard and shall prevail.

			calculation under schedule-9.			
89.	TSA	<p>Clause 5.5.6</p> <p>For any delay in commissioning any critical Element(s), as identified in Schedule 1 & Schedule 2 of this Agreement, beyond a period of 45 days shall lead to a sequestration of 10% of the Contract Performance Guarantee</p>	<p>As a general practice, the CERC considers any request for extension of time post COD of the Project. BPC to clarify that whether the 10% of CPBG will be invoked even when such delay is caused due to FM events and without adjudication on the validity of such claims?</p>		Bidder needs information for proper estimation.	This is as per the SBD and amendments thereof, issued by the Ministry of Power.
90.	TSA	<p>Clause 2.2.2</p> <p>It is required that post the Expiry Date, the TSP to transfer the Project to CTU within a period of 90 days.</p>	<p>BPC to clarify the following:</p> <p>a. Who will be responsible for O&M of the Project post Expiry Date till the Project is transferred as the Agreement will automatically terminate on Expiry Date?</p> <p>Whether the TSP will be paid for the O&M for the period post Expiry Date till the Project is transferred if the TSP will manage the O&M post Expiry Date?</p>		Bidder needs information for proper estimation.	The transfer of all project assets along with substation land, right of way and clearances shall be completed at the end of 35 years from COD of the Project. All the expenditure till the transfer of all project assets along with substation land, right of way and clearances shall be borne by TSP.
91.	TSA	<p>Clauses 4.1(f) and 4.2.1(e)</p> <p>These clauses provide assistance by Nodal Agency or TSP to the Arbitrators as required for the performance of their duties and responsibilities.</p>	<p>BPC to provide the definition of Arbitrators used as defined term.</p>		Bidder needs information for proper estimation.	This is as per the SBD and amendments thereof, issued by the Ministry of Power.

92.	TSA	<p>Schedule 2</p> <p>Month has been defined as a period of 30 days from (and excluding) the date of the event. The Scheduled COD is 18 Months from Effective Date.</p>	<p>BPC to clarify in SCOD, whether month is counted as month-to-month basis, i.e., actual days in the month basis (365 days per year) or as 30 days per Month as defined in TSA (which will be 360 days per year)?</p>		<p>Bidder needs information for proper estimation.</p>	<p>The provisions of TSA are amply clear in this regard and shall prevail.</p>
-----	-----	--	--	--	--	--

Additional Clarifications dated 15.01.2024 on RFP Project Documents for selection of Bidder as Transmission Service Provider to establish Transmission System for “Western Region Network Expansion scheme in Kallam area of Maharashtra” through Tariff Based Competitive Bidding process

S. No.	Name of the document	Clause No. and Existing provision	Clarification required	Suggested text for the Amendment	Rationale for the Clarification or Amendment	RECPDCL Response
1.	RFP	<p>SPECIFIC TECHNICAL REQUIREMENTS FOR TRANSMISSION LINE</p> <p><i>LILO of both circuits of Parli(M) – Karjat(M)/Lonikand-II (M) 400 kV D/c line (twin moose) at Kallam PS</i></p>	<p>Presently, Technical specifications are exclusively outlined for 400kV Double Circuit transmission lines. In this regard, it is to mention that significant severe Right of Way (RoW) challenges were faced by TSP in previous TBCB project in the Osmanabad district, further RoW issues are getting increased on day to day basis, considering the same, we earnestly request the inclusion of an option for bidders to choose between Multi-Circuit and Double Circuit configurations. This flexibility will enable a comprehensive evaluation of the economic and technical feasibility tailored to the specific project requirements.</p> <p>We also kindly request the provision of technical specifications for Multi-Circuit transmission lines.</p>		For optimisation of bid	<p>RfP to be complied.</p> <p>The survey report has been already issued to the bidders following indicative route/corridor for the proposed transmission line. Bidder may decide on considering two double circuit or single multi circuit towers as per their site assessment and provisions of the RfP document, that states, 400kV transmission line shall be D/C except for areas mentioned under clause A.20.0.</p> <p>However, a particular stretch where severe RoW constraint is being faced, the same shall be intimated to CEA/CTU for relaxation of Double Circuit configuration to Multi-Circuit configuration.</p>

Additional Clarifications dated 15.01.2024 on RFP Project Documents for selection of Bidder as Transmission Service Provider to establish Transmission System for “Western Region Network Expansion scheme in Kallam area of Maharashtra” through Tariff Based Competitive Bidding process

S. No.	Name of the document	Clause No. and Existing provision	Clarification required	Suggested text for the Amendment	Rationale for the Clarification or Amendment	RECPDCL Response
1.	Amendment – II dated 27.12.2023 & Single Line Diagram - IGT-KTL-ELEC-SLD- 001 General Arrangement- IGT-KTL-ELEC-LAY- 001	B.1.2 (vi) Kallam S/S: 400kV: Bays identified for LILO of both circuits of Parli(M) – Karjat(M)/Lonikand-II (M) 400 kV D/c line are shown in attached SLD & GA drawing of Kallam S/S. As per the GA drawing out of 4 circuits, 3 circuits shall be terminated in new diameters for which main & tie bays are to be constructed under the present scope. Remaining 1 circuit shall be terminated in main bay no. 419 under present scope for which tie bay is excluded as the same is being constructed in separate scheme. Further, Line gantries shall be constructed for termination of all the four (4) circuits considering the provision of	As per GA and SLD furnished vide Amendment-II dated 27.12.2023, it is observed that out of 4 circuits, 3 circuits shall be terminated in existing diameters for which tie bays are excluded in present scope. The remaining 1 circuit shall be terminated in new diameter for which main & tie bays (bay no. 422 & 423) are to be constructed under present scope. However, in Amendment-II it is mentioned that out of 4 circuits, 3 circuits shall be terminated in new diameters for which main & tie bays are to be constructed under the present scope. Remaining 1 circuit shall be terminated in main bay no. 419 under present scope for which tie bay is excluded as the same		For Technical Clarification/ Amendment	Please refer Amendment-IV in this regard.

S. No.	Name of the document	Clause No. and Existing provision	Clarification required	Suggested text for the Amendment	Rationale for the Clarification or Amendment	RECPDCL Response
		switchable line reactor as shown in GA drawing.	<p>is being constructed in separate scheme.</p> <p>Since the description in Amendment-II & the existing GA, SLD included with the same are contradictory in nature, BPC may kindly confirm the bays to be constructed under present scope.</p>			
2.	RFP	<p>SPECIFIC TECHNICAL REQUIREMENTS FOR TRANSMISSION LINE</p> <p><i>LILO of both circuits of Parli(M) – Karjat(M)/Lonikand-II (M) 400 kV D/c line (twin moose) at Kallam PS</i></p>	<p>Presently, Technical specifications are exclusively outlined for 400kV Double Circuit transmission lines. In this regard, it is to mention that significant severe Right of Way (RoW) challenges were faced by TSP in previous TBCB project in the Osmanabad district, further RoW issues are getting increased on day to day basis, considering the same, we earnestly request the inclusion of an option for bidders to choose between Multi-Circuit and Double Circuit configurations. This flexibility will enable a comprehensive</p>		For optimisation of bid	<p>RfP to be complied.</p> <p>However, a particular stretch where severe RoW constraint is being faced, the same may be mentioned for relaxation of Double Circuit configuration to Multi-Circuit configuration. BPC may also provide details of required length, tower locations and corridor constraint with supporting document.</p>

S. No.	Name of the document	Clause No. and Existing provision	Clarification required	Suggested text for the Amendment	Rationale for the Clarification or Amendment	RECPDCL Response
			<p>evaluation of the economic and technical feasibility tailored to the specific project requirements.</p> <p>We also kindly request the provision of technical specifications for Multi-Circuit transmission lines.</p>			
3.		General	We understand that line reactors to be considered shall be oil-filled type. Please confirm.			Bidder has not indicated the clause reference of RfP. However, clause no. B.2.1 may be referred regarding reactors.
4.		General	For LILO of the existing Parli-Karjat D/c line, please provide the scope of PLCC to be considered in the present scope of work including the shifting work, if any.			<p>Bidder has not indicated the clause reference of RfP. However, clause C.4.0 of RfP shall be referred for PLCC.</p> <p>The scope of PLCC is already mentioned in clause C.4.0 of RfP.</p>
5.	Survey Report	<p>Chapter-1.3 (Coordinates of Proposed Route)</p> <p>Page no 19 and kmz file</p>	In the given kmz and Coordinates of Proposed route Tapping Points are shown as Existing Loc No- 157 and 159 respectively, which are Suspension Towers. Also, it is proposed to insert two D/c	As per Survey Report Chapter 1.1 "Coordinates of Both End" it is written		MSETCL will coordinate with TSP & MSLDC during execution stage for arranging shutdown for this work. However, the availability and duration of outage shall be subject to system prevailing condition and NOC

S. No.	Name of the document	Clause No. and Existing provision	Clarification required	Suggested text for the Amendment	Rationale for the Clarification or Amendment	RECPDCL Response
			towers i.e AP-17 and AP-17A respectively in the same alignment of existing line i.e Parli (M) – Karjat (M) / Lonikand-II(M) 400 Kv D/c Line.	that “The successful Bidder/TSP (Transmission Service Provider) shall finalize the point of termination i.e. the tapping tower in coordination with existing transmission line owner during execution stage” . It is to bring in the kind notice of BPC is that for construction of two D/c line under the corridor of existing line		from WRLDC in consultation with MSLDC. It may be noted that 400 kV D/C from Parli (M) kV to 400 kV Karjat (M) are main source circuits to Pune network and any continuous outage simultaneously on both the circuits may not be feasible. It is therefore suggested to consider alternate options for LILO location to avoid simultaneous outage on both the circuits.

S. No.	Name of the document	Clause No. and Existing provision	Clarification required	Suggested text for the Amendment	Rationale for the Clarification or Amendment	RECPDCL Response
				will require a longer shutdown, dismantling and other associated works. BPC is requested to clarify that during the execution stage existing owner will not ask to TSP for another tapping points at angle towers which are far away from proposed LILO point and allow for required shutdown without any additional charge to		

S. No.	Name of the document	Clause No. and Existing provision	Clarification required	Suggested text for the Amendment	Rationale for the Clarification or Amendment	RECPDCL Response
				TSP for construction of two D/c line within the same alignment and its tapping.		
6.		General	Please provide the scope of FOTE to be considered in the present scope of work including the remote end substations.			<p>TSP shall install FOTE in the new Bay Kiosk at Kallam PS. The FOTE under present scope shall be integrated by TSP with the existing FOTE at CR of Kallam PS. If required, TSP shall provide optical interfaces/equipment in the existing FOTE/FODP panels in control room for integration.</p> <p>In case spare optical direction is not available in the existing FOTE at the control room, the TSP shall coordinate with station owner to reconfigure the directions in existing FOTE at control room.</p> <p>TSP shall also provide necessary optical interfaces in the existing FOTE in CR of Parli</p>

S. No.	Name of the document	Clause No. and Existing provision	Clarification required	Suggested text for the Amendment	Rationale for the Clarification or Amendment	RECPDCL Response
						<p>(M) S/s and Lonikhand (M) S/s if available, to meet the voice and data redundant communication requirement among Kallam S/s, Parli (M) S/s and Lonikand-II (M).</p> <p>TSP is required to provide necessary optical interfaces only in the existing FOTE in CR of Parli (M) S/s and Lonikhand (M) S/s (if available).</p>
7.		General	<p>The proposed "LILO of both circuits of Parli(M) – Karjat(M)/Lonikand-II (M) 400 kV D/c line (twin moose) at Kallam PS" before terminating in Kallam PS, there is a multi-circuit line crossing. As the area is ROW prone, acquiring land for gantry portion from powerline crossing point to substation gantry point is challenging task. We request REC to extend bid timeline to work on alternate solutions.</p>			<p>The response to the query has been already issued to the bidders. However, the same is reiterated again:</p> <p>“The survey report has been already issued to the bidders following indicative route/corridor for the proposed transmission line. Bidder may decide on considering two double circuit or single multi circuit towers as per their site assessment and provisions of the RfP document, that states, 400kV transmission</p>

S. No.	Name of the document	Clause No. and Existing provision	Clarification required	Suggested text for the Amendment	Rationale for the Clarification or Amendment	RECPDCL Response
						line shall be D/C except for areas mentioned under clause A.18.0.”
8.	Clarifications dated 27.12.2023. Amendment – II dated 27.12.2023	SI No 23, 24 The tentative SLD and the plan layout already issued as Appendix A and is again attached with Amendment II for reference. All other drawings are in the development stage.	SLD provided vide referred amendment has three colors marking i.e., Future Scope, Present Scope, and Torrent Power Scope. However, as the present scope marked items include 220kV items, we assume future scope marked items are to be considered for present scope under this RPF. However, as per that, under present scope 3 no of line bays (Bay no. 413, 416, 422) are to be provided in existing half dia, and one line bay (Bay no. 422) is to be provided with associated tie bay (Bay no 423). Hence, as per the SLD, a total of 7 bays (including 2no of bays for SLR) are to be provided under present scope. However, as per Amendment – II dated 27.12.2023, out of 4 circuits, 3 circuits shall be		Bidder needs the information for proper estimation	Please refer Amendment-IV in this regard.

S. No.	Name of the document	Clause No. and Existing provision	Clarification required	Suggested text for the Amendment	Rationale for the Clarification or Amendment	RECPDCL Response
			<p>terminated in new diameters for which main & tie bays are to be constructed under the present scope. Remaining, 1 circuit shall be terminated in main bay no. 419 under present scope, which is not clear from the provided SLD and GA drawing.</p> <p>BPC is requested to mention the bay numbers and highlight the present scope of work in the SLD and GA drawing for better clarity of the scope of work and to eliminate the ambiguity.</p>			
9.	Clarifications dated 27.12.2023	<p>SI No 23, 24</p> <p>The tentative SLD and the plan layout already issued as Appendix A and is again attached with Amendment II for reference. All other drawings are in the development stage.</p>	<p>It is mentioned that the provided SLD is tentative. We understand that the equipment and items marked under torrent power are not in the present scope of work. Please confirm.</p>		Bidder needs the information for proper estimation	Please refer Amendment-IV in this regard. Further, it is clarified that equipment and items marked in bay of torrent power are not envisaged in the present scope of work.

Ref No: RECPDCL/TBCB/Kallam/2023-24/ 3486

Date: 01.01.2024

Mr. Wasim Alam, Senior Manager - Bidding & BD,
M/s IndiGrid 2 Limited,
Unit No 101, First Floor,
Windsor Village, KoleKalyan Off CST Road,
Vidyanagari Marg, Santacruz (East) Mumbai,
Maharashtra - 4000098.

Subject: Unexecuted finalized Transmission Service Agreement (TSA) for "Western Region Network Expansion Scheme in Kallam area of Maharashtra" to be implemented through Tariff Based Competitive Bidding process.

Dear Sir,

This has reference to the RFP dated 13.10.2023 for selection of Transmission Service Provider to establish Transmission System for "Western Region Network Expansion Scheme in Kallam area of Maharashtra" (hereinafter referred to as "the Project") through tariff based competitive bidding process.

As per clause 9.4.3 of Tariff based Competitive-bidding Guidelines for Transmission Service, "The TSP on the date of acquisition of SPV from the BPC will enter into a Transmission Service Agreement (TSA) with the Nodal Agency (in case of interstate projects)/ the concerned utilities (in case of intra State projects)". Accordingly, TSA has to be executed between Nodal Agency i.e., CTU and TSP on the day of transfer of project specific SPV to the selected bidder.

In terms of provisions of Clause 1.6.2.1 (6) of RFP document please find attached copy of unexecuted finalized Transmission Service Agreement after incorporating amendments issued till date of the subject project.

Thanking you,

Yours faithfully,

fw
01/01/2024

(P S Hariharan)

fw Chief General Manager (Tech)

Encl.: As above

**STANDARD
TRANSMISSION SERVICE AGREEMENT**

FOR

**DEVELOPMENT AND OPERATION OF INTER-
STATE TRANSMISSION SYSTEM**

**FOR TRANSMISSION OF ELECTRICITY
THROUGH TARIFF BASED COMPETITIVE
BIDDING FOR**

**WESTERN REGION NETWORK EXPANSION
SCHEME IN KALLAM AREA OF MAHARASHTRA**

BETWEEN THE

**CENTRAL TRANSMISSION UTILITY OF INDIA
LIMITED
(NODAL AGENCY)**

AND

KALLAM TRANSCO LIMITED

XX.XX.2024

CONTENTS

1	Definitions and Interpretations	5
2	Effectiveness and Term of Agreement	17
3	Conditions Subsequent	19
4	Development of the Project	24
5	Construction of the Project	29
6	Connection and commissioning of the Project.....	34
7	Operation and Maintenance of the Project	39
8	Availability of the project.....	40
9	Insurances	41
10	Billing And Payment of Transmission Charges.....	43
11	Force Majeure	44
12	Change in Law.....	49
13	Events of Default and Termination	52
14	Liability and Indemnification	57
15	Assignments and Charges	63
16	Governing Law and Dispute Resolution	65
17	Representation and Warranties.....	67
18	Independent Engineer	69
19	Miscellaneous Provisions	71

THIS TRANSMISISON SERVICE AGREEMENT (hereinafter referred to as "TSA" or "Agreement" or "the Agreement" or "this Agreement") is made on the [Insert day] of..... [Insert month] of Two Thousand and..... [Insert Year]

BETWEEN:

The[Insert name and registered address of Nodal Agency for the project], acting as a Nodal Agency (referred to as the "Nodal Agency"), which expression shall unless repugnant to the context or meaning thereof include its successors, and permitted assigns) as Party of the one part;

AND

..... [Insert Name of the Transmission Service Provider], incorporated under the Companies Act, 1956/ Companies Act, 2013 (as the case may be), having its registered office at (herein after referred to as "Transmission Service Provider" or "TSP" or "ISTS Licensee", which expression shall unless repugnant to the context or meaning thereof include its successors, and permitted assigns) as Party of the other part;

("Nodal Agency" and "TSP" are individually referred to as "Party" and collectively as the "Parties")

AND WHEREAS:

- A) In accordance with the Bidding Guidelines, the Bid Process Coordinator (hereinafter referred to as BPC) had initiated a competitive e-reverse bidding process through issue of RFP for selecting a Successful Bidder to build, own, operate and transfer the Project comprising of the Elements mentioned in Schedule 1 (hereinafter referred to as the Project)
- B) Pursuant to the said e-reverse bidding process, the BPC has identified the Successful Bidder, who will be responsible to set up the Project on build, own, operate and transfer basis to provide Transmission Service in accordance with the terms of this Agreement and the Transmission License.

- C) The Selected Bidder have submitted the Contract Performance Guarantee and acquired one hundred percent (100%) of the equity shareholding of Kallam Transco Limited, along with all its related assets and liabilities in terms of the provisions of the Share Purchase Agreement.
- D) The TSP has agreed to make an application for a Transmission License to the Commission for setting up the Project on build, own, operate and transfer basis.
- E) The TSP has further agreed to make an application to the Commission for the adoption of the Transmission Charges under Section 63 of the Electricity Act, 2003, along with a certification from the Bid Evaluation Committee in accordance with the Bidding Guidelines issued by Ministry of Power, Government of India.
- F) The TSP has agreed to execute the agreement(s) required, if any, under Sharing Regulations within fifteen (15) days from the date of grant of Transmission License from the Commission.
- G) The TSP agrees to the terms and conditions laid down under Sharing Regulations, for making available the ISTS and charge the Transmission Charges in accordance with the terms and conditions of Sharing Regulations.
- H) The billing, collection and disbursement of the Transmission Charges by the CTU to the ISTS Licensee shall be governed as per Sharing Regulations.
- I) The terms and conditions stipulated in the Transmission License issued by the Commission to the TSP shall be applicable to this Agreement and the TSP agrees to comply with these terms and conditions. In case of inconsistency between the Transmission License terms & conditions and the conditions of this Agreement, the conditions stipulated in the Transmission License granted by the Commission shall prevail.

NOW, THEREFORE, IN CONSIDERATION OF THE PREMISES AND MUTUAL AGREEMENTS, COVENANTS AND CONDITIONS SET FORTH HEREIN, IT IS HEREBY AGREED BY AND BETWEEN THE PARTIES HERETO AS FOLLOWS:

ARTICLE: 1**1 DEFINITIONS AND INTERPRETATIONS****1.1 Definitions:**

- 1.1.1 The words / expressions used in this Agreement, unless as defined below or repugnant to the context, shall have the same meaning as assigned to them by the Electricity Act, 2003 and the rules or regulations framed there under including those issued / framed by the Commission (as defined hereunder), as amended or re-enacted from time to time or the General Clauses Act, failing which it shall bear its ordinary English meaning.

The words/expressions when used in this Agreement shall have the respective meanings as specified below:

“Acquisition Price” shall have the same meaning as defined in the Share Purchase Agreement;

“Act” or **"Electricity Act"** or **“Electricity Act 2003”** shall mean the Electricity Act, 2003 and any amendments made to the same or any succeeding enactment thereof;

“Affiliate” shall mean a company that either directly or indirectly

- i. controls or
- ii. is controlled by or
- iii. is under common control with

a Bidding Company (in the case of a single company) or a Member (in the case of a Consortium) and **“control”** means ownership by one entity of at least twenty-six percent (26%) of the voting rights of the other entity;

“Availability” in relation to the Project or in relation to any Element of the Project, for a given period shall mean the time in hours during that period the Project is capable to transmit electricity at its Rated Voltage and shall be expressed in percentage of total hours in the given period and shall be calculated as per the procedure contained in Appendix –II to Central Electricity Regulatory Commission (Terms and Conditions of Tariff) Regulations, 2019, attached herewith in Schedule 6;

“Bid” shall mean technical bid and financial bid submitted by the Bidder, in response to the RFP, in accordance with the terms and conditions of the RFP;

“**Bid Deadline**” shall mean the last date and time for submission of the Bid in response to RFP, as specified in the RFP;

“**Bidding Company**” shall refer to such single company that has made a Response to RFP for the Project;

“**Bidding Consortium / Consortium**” shall refer to a group of companies that has collectively made a Response to RFP for the Project;

“**Bid Documents**” or “**Bidding Documents**” shall mean the RFP, along with all attachments thereto or clarifications thereof;

“**Bidding Guidelines**” shall mean the “Tariff Based Competitive Bidding Guidelines for Transmission Service” and “Guidelines for Encouraging Competition in Development of Transmission Projects” issued by Government of India, Ministry of Power under Section – 63 of the Electricity Act as amended from time to time;

“**Bid Process Coordinator**” or “**BPC**” shall mean a person or its authorized representative as notified by the Government of India, responsible for carrying out the process for selection of Bidder who will acquire Transmission Service Provider;

“**Bill**” shall mean any bill raised by the CTU on the DICs to recover the Transmission Charges pursuant to the Sharing Regulations;

“**Business Day**” shall mean a day other than Sunday or a statutory holiday, on which the banks remain open for business in the State in which the Nodal Agency’s registered office is located and the concerned TSP are located;

“**CEA**” shall mean the Central Electricity Authority constituted under Section -70 of the Electricity Act;

“**Change in law**” shall have the meaning ascribed thereto in Article 12;

“**Commercial Operation Date**” or “**COD**” shall mean the date as per Article 6.2;

“**Commission**” or “**CERC**” shall mean the Central Electricity Regulatory Commission referred to in sub-section (1) of Section 76 of the Electricity Act, 2003 or its successors and assigns;

“**Competent Court of Law**” shall mean the Supreme Court or any High Court, or any tribunal or any similar judicial or quasi-judicial body in India that has jurisdiction to adjudicate upon issues relating to the Project;

“Connection Agreement” shall mean the agreement between the CTU or STU or any other concerned parties and the TSP, setting out the terms relating to the connection of the Project to the Inter-Connection Facilities and use of the Inter State Transmission System as per the provisions of the IEGC, as the case may be;

“Consultation Period” shall mean the period of sixty (60) days or such longer period as the Parties may agree, commencing from the date of issue of a TSP’s Preliminary Notice or a Nodal Agency’s Preliminary Termination Notice, as provided in Article 13 of this Agreement, for consultation between the Parties to mitigate the consequence of the relevant event having regard to all the circumstances;

“Consents, Clearances and Permits” shall mean all authorizations, licenses, approvals, registrations, permits, waivers, privileges, acknowledgements, agreements, or concessions required to be obtained from or provided by any concerned authority for the development, execution and operation of Project including without any limitation for the construction, ownership, operation and maintenance of the Transmission Lines and/or sub-stations;

“Construction Period” shall mean the period from (and including) the Effective Date of the Transmission Service Agreement up to (but not including) the COD of the Element of the Project in relation to an Element and up to (but not including) the COD of the Project in relation to the Project;

“Contractors” shall mean the engineering, procurement, construction, operation & maintenance contractors, surveyors, advisors, consultants, designers, suppliers to the TSP and each of their respective sub-contractors (and each of their respective successors and permitted assigns) in their respective capacities as such;

“Contract Performance Guarantee” shall mean the irrevocable unconditional bank guarantee, submitted and to be submitted by the TSP or by the Selected Bidder on behalf of the TSP to the Nodal Agency from a bank mentioned in Annexure 17 of the RFP, in the form attached here to as Schedule 8, in accordance with Article 3 of this Agreement and which shall include the additional bank guarantee furnished by the TSP under this Agreement;

“Contract Year”, for the purpose of payment of Transmission Charges, shall mean the period beginning on the COD, and ending on the immediately succeeding March 31 and thereafter each period of 12

months beginning on April 1 and ending on March 31 provided that the last Contract Year shall end on the last day of the term of the TSA;

“CTU” or **“Central Transmission Utility”** shall have same meaning as defined in the Electricity Act, 2003;

“Day” shall mean a day starting at 0000 hours and ending at 2400 hours;

“D/C” shall mean Double Circuit;

“Designated ISTS Customers” or **“DICs”** shall have the meaning as ascribed in the Sharing Regulations;

“Dispute” shall mean any dispute or difference of any kind between the Parties, in connection with or arising out of this Agreement including any issue on the interpretation and scope of the terms of this Agreement as provided in Article 16;

“Effective Date” for the purposes of this Agreement, shall have the same meaning as per Article 2.1 of this Agreement;

“Electrical Inspector” shall mean a person appointed as such by the Government under sub-section (1) of Section 162 of the Electricity Act 2003 and also includes Chief Electrical Inspector;

“Electricity Rules 2005” shall mean the rules framed pursuant to the Electricity Act 2003 and as amended from time to time;

“Element” shall mean each Transmission Line or each circuit of the Transmission Lines (where there are more than one circuit) or each bay of Sub-station or switching station or HVDC terminal or inverter station of the Project, including ICTs, Reactors, SVC, FSC, etc. forming part of the ISTS, which will be owned, operated and maintained by the concerned ISTS Licensee, and which has a separate Scheduled COD as per Schedule 2 of this Agreement and has a separate percentage for recovery of Transmission Charges on achieving COD as per Schedule 5 of this Agreement;

“Event of Default” shall mean the events as defined in Article 13 of this Agreement;

“Expiry Date” shall be the date which is thirty-five (35) years from the COD of the Project;

“Financial Closure” shall mean the first Business Day on which funds are made available to the TSP pursuant to the Financing Agreements;

“Financially Evaluated Entity” shall mean the company which has been evaluated for the satisfaction of the financial requirement set forth in the RFP;

“Financing Agreements” shall mean the agreements pursuant to which the TSP is to finance the Project including the loan agreements, security documents, notes, indentures, security agreements, letters of credit and other documents, as may be amended, modified, or replaced from time to time, but without in anyway increasing the liabilities of the Designated ISTS Customers / Nodal Agency;

“Financial Year” shall mean a period of twelve months at midnight Indian Standard Time (IST) between 1st April & 31st March;

“Force Majeure” and **“Force Majeure Event”** shall have the meaning assigned thereto in Article 11;

“GOI” shall mean Government of India;

“Grid Code” / “IEGC” shall mean the Grid Code specified by the Central Commission under Clause (h) of sub-section (1) of Section 79 of the Electricity Act;

“Independent Engineer” shall mean an agency/ company, appointed by Nodal Agency in accordance with the Guidelines for Encouraging Competition in Development of Transmission Projects.

“Indian Governmental Instrumentality” shall mean Government of India, Government of any State in India or any ministry, department, board, authority, agency, corporation, commission under the direct or indirect control of Government of India or any State Government or both, any political sub-division of any of them including any court or Commission or tribunal or judicial or quasi-judicial body in India but excluding the CTU, TSP and the Designated ISTS Customers;

“Insurances” shall mean the insurance cover to be obtained and maintained by the TSP in accordance with Article 9 of this Agreement;

“Interconnection Facilities” shall mean the facilities as may be set up for transmission of electricity through the use of the Project, on either one or both side of generating station's / CTU's / STU's / ISTS Licensee's / Designated ISTS Customer's substations (as the case may be) which shall include, without limitation, all other transmission lines, gantries, substations and associated equipments not forming part of the Project;

“ISTS Licensee” shall be the TSP under this Agreement, consequent to having been awarded a Transmission License by the CERC and shall be referred to as the TSP or the ISTS Licensee, as the context may require in this Agreement;

“Law” or “Laws” in relation to this Agreement, shall mean all laws including electricity laws in force in India and any statute, ordinance, rule, regulation, notification, order or code, or any interpretation of any of them by an Indian Governmental Instrumentality having force of law and shall include all rules, regulations, decisions and orders of the Commission;

“Lead Member of the Bidding Consortium” or “Lead Member” shall mean a company who commits at least 26% equity stake in the Project, meets the technical requirement as specified in the RFP and so designated by other Member(s) in Bidding Consortium;

“Lenders” means the banks, financial institutions, multilateral funding agencies, non-banking financial companies registered with the Reserve Bank of India (RBI), insurance companies registered with the Insurance Regulatory & Development Authority (IRDA), pension funds regulated by the Pension Fund Regulatory & Development Authority (PFRDA), mutual funds registered with Securities & Exchange Board of India (SEBI), etc., including their successors and assigns, who have agreed on or before COD of the Project to provide the TSP with the debt financing described in the capital structure schedule, and any successor banks or financial institutions to whom their interests under the Financing Agreements may be transferred or assigned;

Provided that, such assignment or transfer shall not relieve the TSP of its obligations to the Nodal Agency under this Agreement in any manner and shall also does not lead to an increase in the liability of the Nodal Agency;

“Lenders Representative” shall mean the person notified by the Lender(s) in writing as being the representative of the Lender(s) or the Security Trustee and such person may from time to time be replaced by the Lender(s) pursuant to the Financing Agreements by written notice to the TSP;

“Letter of Intent” or “LOI” shall have the same meaning as in the RFP;

“Member in a Bidding Consortium / Member” shall mean each company in the Bidding Consortium;

“Month” shall mean a period of thirty (30) days from (and excluding) the date of the event;

“Monthly Transmission Charges” for any Element of the Project, after COD of the Element till COD of the Project, and for the Project after COD of the Project, shall mean the amount of Transmission Charges as specified in Schedule 5 of this Agreement multiplied by no. of days in the relevant month and divided by no. of days in the year;

“National Load Despatch Centre” shall mean the centre established as per sub-section (1) of Section 26 of the Electricity Act 2003;

“Nodal Agency” shall mean CTU, which shall execute and implement the Transmission Service Agreement (TSA);

Provided that while taking major decisions, CTU shall consult CEA on technical matters and any other matter it feels necessary.

“Notification” shall mean any notification, issued in the Gazette of India;

“Operating Period” for any Element of the Project shall mean the period from (and including) the COD of such Element of the Project, up to (and including) the Expiry Date and for the Project, shall mean the period from (and including) the COD of the Project, up to (and including) the Expiry Date;

“Parent Company” shall mean an entity that holds at least twenty-six percent (26%) of the paid - up equity capital directly or indirectly in the Bidding Company or in the Member in a Bidding Consortium, as the case may be;

“Preliminary Termination Notice” shall mean a Nodal Agency’s Preliminary Termination Notice as defined in Article 13 of this Agreement;

“Project” shall mean Western Region Network Expansion scheme in Kallam area of Maharashtra, as detailed in Schedule 1 of this Agreement;

“Project Assets” shall mean all physical and other assets relating to and forming part of the Project including:

(a) rights over the Site for substations, ROW for transmission lines;

(b) tangible & intangible assets such as civil works and equipment including foundations, embankments, pavements, electrical systems, communication systems, relief centres, administrative offices, Sub-stations, software, tower and sub-stations designs etc;

(c) project facilities situated on the Site;

- (d) all rights of the TSP under the project agreements;
- (e) financial assets, such as receivables, security deposits etc;
- (f) insurance proceeds; and
- (g) Applicable Permits and authorisations relating to or in respect of the Transmission System;”

“**Project Execution Plan**” shall mean the plan referred to in Article 3.1.3(c) hereof;

“**Prudent Utility Practices**” shall mean the practices, methods and standards that are generally accepted internationally from time to time by electric transmission utilities for the purpose of ensuring the safe, efficient and economic design, construction, commissioning, operation, repair and maintenance of the Project and which practices, methods and standards shall be adjusted as necessary, to take account of:

- (i) operation, repair and maintenance guidelines given by the manufacturers to be incorporated in the Project,
- (ii) the requirements of Law, and
- (iii) the physical conditions at the Site;
- (iv) the safety of operating personnel and human beings;

“**Rated Voltage**” shall mean voltage at which the Transmission System is designed to operate or such lower voltage at which the line is charged, for the time being, in consultation with the Central Transmission Utility;

“**Rebate**” shall have the meaning as ascribed to in Article 10.3 of this Agreement;

“**RFP**” shall mean Request for Proposal dated along with all schedules, annexures and RFP Project Documents attached thereto, issued by the BPC for tariff based competitive bidding process for selection of Bidder as TSP to execute the Project, including any modifications, amendments or alterations thereto;

“**RFP Project Documents**” shall mean the following documents to be entered into in respect of the Project, by the Parties to the respective agreements:

- a. Transmission Service Agreement,

- b. Share Purchase Agreement,
- c. Agreement(s) required under Sharing Regulations and
- d. Any other agreement as may be required;

“RLDC” shall mean the relevant Regional Load Dispatch Centre as defined in the Electricity Act, 2003, in the region(s) in which the Project is located;

“RPC” shall mean the relevant Regional Power Committee established by the Government of India for the specific Region(s) in accordance with the Electricity Act, 2003 for facilitating integrated operation of the Power System in that Region;

“Scheduled COD” in relation to an Element(s) shall mean the date(s) as mentioned in Schedule 2 as against such Element(s) and in relation to the Project, shall mean the date as mentioned in Schedule 2 as against such Project, subject to the provisions of Article 4.4 of this Agreement, or such date as may be mutually agreed among the Parties;

“Scheduled Outage” shall mean the final outage plan as approved by the RPC as per the provisions of the Grid Code;

“Selected Bid” shall mean the technical Bid and the Final Offer of the Selected Bidder submitted during e-reverse bidding, which shall be downloaded and attached in Schedule 7 on or prior to the Effective Date;

“Share Purchase Agreement” shall mean the agreement amongst REC Power Development and Consultancy Limited, Kallam Transco Limited and the Successful Bidder for the purchase of one hundred (100%) per cent of the shareholding of the Kallam Transco Limited for the Acquisition Price, by the Successful Bidder on the terms and conditions as contained therein;

“Sharing Regulations” shall mean the Central Electricity Regulatory Commission (Sharing of Inter-State Transmission Charges and Losses) Regulations, 2020 and as amended from time to time;

“Site” in relation to a substation, switching station or HVDC terminal or inverter station, shall mean the land and other places upon which such station / terminal is to be established;

“SLDC” shall mean the State Load Dispatch Centre established as per sub-section (1) of Section 31 of the Electricity Act 2003;

“STU” or **“State Transmission Utility”** shall be the Board or the Government company, specified as such by the State Government under sub-section (1) of Section 39 of the Electricity Act 2003;

“Successful Bidder” or **“Selected Bidder”** shall mean the Bidder selected pursuant to the RFP and who has to acquire one hundred percent (100%) equity shares of Kallam Transco Limited, along with all its related assets and liabilities, which will be responsible as the TSP to establish the Project on build, own, operate and transfer basis as per the terms of the TSA and other RFP Project Documents;

“TSP’s Preliminary Notice” shall mean a notice issued by the TSP in pursuant to the provisions of Article 13.3 of this Agreement;

“Target Availability” shall have the meaning as ascribed hereto in Article 8.2 of this Agreement;

“Technically Evaluated Entity” shall mean the company which has been evaluated for the satisfaction of the technical requirement set forth in RFP;

“Termination Notice” shall mean a Nodal Agency’s Termination Notice given by the Nodal Agency to the TSP pursuant to the provisions of Articles 3.3.2, 3.3.4, 4.4.2, 5.8, 13.2 and 13.3 of this Agreement for the termination of this Agreement;

“Term of Agreement” for the purposes of this Agreement shall have the meaning ascribed thereto in Article 2.2 of this Agreement;

“Transmission Charges” shall mean the Final Offer of the Selected Bidder during the e-reverse bidding and adopted by the Commission, payable to the TSP as per Sharing Regulations;

“Transmission License” shall mean the license granted by the Commission in terms of the relevant regulations for grant of such license issued under the Electricity Act;

“Transmission Service” shall mean making the Project available as per the terms and conditions of this Agreement and Sharing Regulations;

“Unscheduled Outage” shall mean an interruption resulting in reduction of the Availability of the Element(s) / Project (as the case may be) that is not a result of a Scheduled Outage or a Force Majeure Event.

“Ultimate Parent Company” shall mean an entity which owns at least twenty six percent (26%) equity in the Bidding Company or Member of a Consortium, (as the case may be) and in the Technically Evaluated Entity

and / or Financially Evaluated Entity (as the case may be) and such Bidding Company or Member of a Consortium, (as the case may be) and the Technically Evaluated Entity and / or Financially Evaluated Entity (as the case may be) shall be under the direct control or indirectly under the common control of such entity;

1.2 Interpretation:

Save where the contrary is indicated, any reference in this Agreement to:

"Agreement" shall be construed as including a reference to its Schedules, Appendices and Annexures;

"Rupee", "Rupees" and "Rs." shall denote lawful currency of India;

"crore" shall mean a reference to ten million (10,000,000) and a **"lakh"** shall mean a reference to one tenth of a million (1,00,000);

"encumbrance" shall be construed as a reference to a mortgage, charge, pledge, lien or other encumbrance securing any obligation of any person or any other type of preferential arrangement (including, without limitation, title transfer and retention arrangements) having a similar effect;

"holding company" of a company or corporation shall be construed as a reference to any company or corporation of which the other company or corporation is a subsidiary;

"indebtedness" shall be construed so as to include any obligation (whether incurred as principal or surety) for the payment or repayment of money, whether present or future, actual or contingent;

"person" shall have the meaning as defined in Section 2 (49) of the Act;

"subsidiary" of a company or corporation (the holding company) shall be construed as a reference to any company or corporation:

- (i) which is controlled, directly or indirectly, by the holding company, or
- (ii) more than half of the issued share capital of which is beneficially owned, directly or indirectly, by the holding company, or
- (iii) which is a subsidiary of another subsidiary of the holding company,

for these purposes, a company or corporation shall be treated as being controlled by another if that other company or corporation is

able to direct its affairs and/or to control the composition of its board of directors or equivalent body;

"winding-up", "dissolution", "insolvency", or "reorganization" in the context of a company or corporation shall have the same meaning as defined in the Companies Act, 1956/ Companies Act, 2013 (as the case may be).

- 1.2.1 Words importing the singular shall include the plural and vice versa.
- 1.2.2 This Agreement itself or any other agreement or document shall be construed as a reference to this or to such other agreement or document as it may have been, or may from time to time be, amended, varied, novated, replaced or supplemented.
- 1.2.3 A Law shall be construed as a reference to such Law including its amendments or re-enactments from time to time.
- 1.2.4 A time of day shall, save as otherwise provided in any agreement or document be construed as a reference to Indian Standard Time.
- 1.2.5 Different parts of this Agreement are to be taken as mutually explanatory and supplementary to each other and if there is any inconsistency between or among the parts of this Agreement, they shall be interpreted in a harmonious manner so as to give effect to each part.
- 1.2.6 The tables of contents and any headings or sub-headings in this Agreement have been inserted for ease of reference only and shall not affect the interpretation of this Agreement.
- 1.2.7 All interest payable under this Agreement shall accrue from day to day and be calculated on the basis of a year of three hundred and sixty five (365) days.
- 1.2.8 The words "hereof" or "herein", if and when used in this Agreement shall mean a reference to this Agreement.
- 1.2.9 The contents of Schedule 7 shall be referred to for ascertaining accuracy and correctness of the representations made by the Selected Bidder in Article 17.2.1 hereof.

ARTICLE: 2**2 EFFECTIVENESS AND TERM OF AGREEMENT****2.1 Effective Date:**

This Agreement shall be effective from later of the dates of the following events:

- a. The Selected Bidder, on behalf of the TSP, has provided the Contract Performance Guarantee, as per terms of Article 3.1 of this Agreement; and
- b. The Selected Bidder has acquired for the Acquisition Price, one hundred percent (100%) of the equity shareholding of REC Power Development and Consultancy Limited in Kallam Transco Limited along with all its related assets and liabilities as per the provisions of the Share Purchase Agreement. and
- c. The Agreement is executed and delivered by the Parties;

2.2 Term and Termination:

2.2.1 Subject to Article 2.2.3 and Article 2.4, this Agreement shall continue to be effective in relation to the Project until the Expiry Date, when it shall automatically terminate.

2.2.2 Post the Expiry Date of this Agreement, the TSP shall ensure transfer of Project Assets to CTU or its successors or an agency as decided by the Central Government at zero cost and free from any encumbrance and liability. The transfer shall be completed within 90 days of expiry of this Agreement failing which CTU shall be entitled to take over the Project Assets Suo moto.

2.2.3 This Agreement shall terminate before the Expiry Date in accordance with Article 13 or Article 3.3.2 or Article 3.3.4.

2.3 Conditions prior to the expiry of the Transmission License

2.3.1 In order to continue the Project beyond the expiry of the Transmission License, the TSP shall be obligated to make an application to the Commission at least two (2) years before the date of expiry of the Transmission License, seeking the Commission's approval for the extension of the term of the Transmission License up to the Expiry Date.

2.3.2 The TSP shall timely comply with all the requirements that may be laid down by the Commission for extension of the term of the Transmission License beyond the initial term of twenty-five (25) years & upto the Expiry Date and the TSP shall keep the Nodal Agency fully informed about the progress on its application for extension of the term of the Transmission License.

2.4 Survival:

The expiry or termination of this Agreement shall not affect any accrued rights, obligations/ roles and liabilities of the Parties under this Agreement, including the right to receive liquidated damages as per the terms of this Agreement, nor shall it effect the survival of any continuing obligations/ roles for which this Agreement provides, either expressly or by necessary implication, which are to survive after the Expiry Date or termination including those under Articles 3.3.3, 3.3.5, Article 9.3 (Application of Insurance Proceeds), Article 11 (Force Majeure), Article 13 (Events of Default and Termination), Article 14 (Liability & Indemnification), Article 16 (Governing Law & Dispute Resolution), Article 19 (Miscellaneous).

2.5 Applicability of the provisions of this Agreement

2.5.1 For the purpose of Availability, Target Availability and the computation of Availability, Incentive, Penalty, the provisions provided in this Agreement shall apply and any future modifications in the relevant Rules and Regulations shall not be applicable for this Project.

2.5.2 For the purposes of this Agreement for ISTS systems developed under the tariff based competitive bidding framework, the provisions relating to the definitions (Availability and COD), Article 3 (Contract Performance Guarantee and Conditions Subsequent), Article 5 (Construction of the Project), Article 6 (Connection and Commissioning of the Project), Article 8 (Target Availability and calculation of Availability), Article 11 (Force Majeure), Article 12 (Change in Law), Article 13 (Event of Default), Article 14 (Indemnification), Article 15 (Assignment and Charges), Articles 16.1, 16.2 and 16.4 (Governing Laws and Dispute Resolution) and Article 17 (representation and warranties of the ISTS Licensee) of this agreement shall supersede the corresponding provisions under Sharing Regulations.

ARTICLE: 3**3 CONDITIONS SUBSEQUENT****3.1 Satisfaction of conditions subsequent by the TSP**

3.1.1 Within ten (10) days from the date of issue of Letter of Intent, the Selected Bidder, shall:

- a. Provide the Contract Performance Guarantee, and
- b. Acquire, for the Acquisition Price, one hundred percent (100%) equity shareholding of Kallam Transco Limited from REC Power Development and Consultancy Limited, who shall sell to the Selected Bidder, the equity shareholding of Kallam Transco Limited, along with all its related assets and liabilities.
- c. Execute this Agreement;

The TSP shall, within five (5) working days from the date of acquisition of SPV by the Selected Bidder, undertake to apply to the Commission for the grant of Transmission License and for the adoption of tariff as required under section-63 of the Electricity Act.

The Selected Bidder, on behalf of the TSP, will provide to the Central Transmission Utility of India Limited (being the Nodal Agency) the Contract Performance Guarantee for an amount of Rs. 3.0 (Rupees Three Crore only).

3.1.2 The Contract Performance Guarantee shall be initially valid for a period up to three (3) months after the Scheduled COD of the Project and shall be extended from time to time to be valid for a period up to three (3) months after the COD of the Project. In case the validity of the Contract Performance Guarantee is expiring before the validity specified in this Article, the TSP shall, at least thirty (30) days before the expiry of the Contract Performance Guarantee, replace the Contract Performance Guarantee with another Contract Performance Guarantee or extend the validity of the existing Contract Performance Guarantee until the validity period specified in this Article.

3.1.3 The TSP agrees and undertakes to duly perform and complete the following activities within six (6) months from the Effective Date (except for c) below), unless such completion is affected due to any Force Majeure Event, or if any of the activities is specifically waived in writing

by the Nodal Agency:

- a. To obtain the Transmission License for the Project from the Commission;
- b. To obtain the order for adoption of Transmission Charges by the Commission, as required under Section 63 of the Electricity Act 2003;
- c. To submit to the Nodal Agency, CEA & Independent Engineer, the Project Execution Plan, immediately after award of contract(s) and maximum within one hundred and twenty (120) days from the Effective Date. Also, an approved copy each of Manufacturing Quality Plan (MQP) and Field Quality Plan (FQP) would be submitted to Independent Engineer & Nodal Agency in the same time period. The TSP's Project Execution Plan should be in conformity with the Scheduled COD as specified in Schedule 2 of this Agreement, and shall bring out clearly the organization structure, time plan and methodology for executing the Project, award of major contracts, designing, engineering, procurement, shipping, construction, testing and commissioning to commercial operation;
- d. To submit to the Nodal Agency, CEA & Independent Engineer a detailed bar (GANTT) chart of the Project outlining each activity (taking longer than one Month), linkages as well as durations;
- e. To submit to the Nodal Agency, CEA & Independent Engineer detailed specifications of conductor meeting the functional specifications specified in RFP;
- f. To achieve Financial Closure;
- g. To provide an irrevocable letter to the Lenders duly accepting and acknowledging the rights provided to the Lenders under the provisions of Article 15.3 of this Agreement and all other RFP Project Documents;
- h. To award the Engineering, Procurement and Construction contract ("EPC contract") for the design and construction of the Project and shall have given to such Contractor an irrevocable notice to proceed; and
- i. To sign the Agreement(s) required, if any, under Sharing Regulations.

3.2 Recognition of Lenders' Rights by the Nodal Agency

3.2.1 The Nodal Agency hereby accepts and acknowledges the rights provided to the Lenders as per Article 15.3 of this Agreement and all other RFP Project Documents.

3.3 Consequences of non-fulfilment of conditions subsequent

3.3.1 If any of the conditions specified in Article 3.1.3 is not duly fulfilled by the TSP even within three (3) Months after the time specified therein, then on and from the expiry of such period and until the TSP has satisfied all the conditions specified in Article 3.1.3, the TSP shall, on a monthly basis, be liable to furnish to Central Transmission Utility of India Limited (being the Nodal Agency) additional Contract Performance Guarantee of Rs. 0.30 Crore (Rupees Thirty Lakhs Only) within two (2) Business Days of expiry of every such Month. Such additional Contract Performance Guarantee shall be provided to Central Transmission Utility of India Limited (being the Nodal Agency) in the manner provided in Article 3.1.1 and shall become part of the Contract Performance Guarantee and all the provisions of this Agreement shall be construed accordingly. Central Transmission Utility of India Limited (being the Nodal Agency) shall be entitled to hold and / or invoke the Contract Performance Guarantee, including such additional Contract Performance Guarantee, in accordance with the provisions of this Agreement.

3.3.2 Subject to Article 3.3.4, if:

- (i) the fulfilment of any of the conditions specified in Article 3.1.3 is delayed beyond nine (9) Months from the Effective Date and the TSP fails to furnish additional Contract Performance Guarantee to the Nodal Agency in accordance with Article 3.3.1 hereof; or
- (ii) the TSP furnishes additional Performance Guarantee to the Nodal Agency in accordance with Article 3.3.1 hereof but fails to fulfil the conditions specified in Article 3.1.3 within a period of twelve (12) months from the Effective Date,

the Nodal Agency shall have the right to terminate this Agreement, by giving a Termination Notice to the TSP, in writing, of at least seven (7) days, with a copy to CEA and the Lenders' Representative in order to enable the Lenders to exercise right of substitution in accordance with Article 15.3 of this Agreement.

3.3.3 If the Nodal Agency elects to terminate this Agreement as per the provisions of Article 3.3.2, the TSP shall be liable to pay to the Nodal

Agency an amount of Rs. 3.0 Crore (Rupees Three Crore only) as liquidated damages. The Nodal Agency shall be entitled to recover this amount of damages by invoking the Contract Performance Guarantee to the extent of liquidated damages, which shall be required by the Nodal Agency, and the balance shall be returned to TSP, if any.

It is clarified for removal of doubt that this Article shall survive the termination of this Agreement.

- 3.3.4 In case of inability of the TSP to fulfil the conditions specified in Article 3.1.3 due to any Force Majeure Event, the time period for fulfilment of the condition subsequent as mentioned in Article 3.1.3, may be extended for a period of such Force Majeure Event. Alternatively, if deemed necessary, this Agreement may be terminated by the Nodal Agency by giving a Termination Notice to the TSP, in writing, of at least seven (7) days, with a copy to CEA and the Lenders' Representative in order to enable the Lenders to exercise right of substitution in accordance with Article 15.3 of this Agreement and the Contract Performance Guarantee shall be returned as per the provisions of Article 6.5.1.

Provided, that due to the provisions of this Article 3.3.4, any increase in the time period for completion of conditions subsequent mentioned under Article 3.1.3, shall lead to an equal increase in the time period for the Scheduled COD. If the Scheduled COD is extended beyond a period of one hundred eighty (180) days due to the provisions of this Article 3.3.4, the TSP will be allowed to recover the interest cost during construction corresponding to the period exceeding one hundred eighty (180) days by adjustment in the Transmission Charges in accordance with Schedule 9.

- 3.3.5 Upon termination of this Agreement as per Articles 3.3.2 and 3.3.4, the Nodal Agency may take steps to bid out the Project again.
- 3.3.6 The Nodal agency, on the failure of the TSP to fulfil its obligations, if it considers that there are sufficient grounds for so doing, apart from invoking the Contract Performance Guarantee under para 3.3.3 may also initiate proceedings for blacklisting the TSP as per provisions of Article 13.2 of TSA.

3.4 Progress Reports

The TSP shall notify the Nodal Agency and CEA in writing at least once a

Month on the progress made in satisfying the conditions subsequent in Articles 3.1.3.

ARTICLE: 4**4 DEVELOPMENT OF THE PROJECT****4.1 TSP's obligations in development of the Project:**

Subject to the terms and conditions of this Agreement, the TSP at its own cost and expense shall observe, comply with, perform, undertake and be responsible:

- a. for procuring and maintaining in full force and effect all Consents, Clearances and Permits, required in accordance with Law for development of the Project;
- b. for financing, constructing, owning and commissioning each of the Element of the Project for the scope of work set out in Schedule 1 of this Agreement in accordance with:
 - i. the Electricity Act and the Rules made thereof;
 - ii. the Grid Code;
 - iii. the CEA Regulations applicable, and as amended from time to time, for Transmission Lines and sub-stations:
 - the Central Electricity Authority (Technical Standards for Connectivity to the Grid) Regulations, 2007;
 - Central Electricity Authority (Technical Standards for construction of Electrical Plants and Electric Lines) Regulation, 2010;
 - Central Electricity Authority (Grid Standard) Regulations, 2010;
 - Central Electricity Authority (Safety requirements for construction, operation and maintenance of Electrical Plants and Electrical Lines) Regulation, 2011;
 - Central Electricity Authority (Measures relating to Safety and Electricity Supply) Regulation, 2010;
 - Central Electricity Authority (Technical Standards for Communication System in Power System Operation) Regulations, 2020.

Transmission Service Agreement

- iv. Safety/ security Guidelines laid down by the Government;
- v. Prudent Utility Practices, relevant Indian Standards and the Law;

not later than the Scheduled COD as per Schedule 2 of this Agreement;

- c. for entering into a Connection Agreement with the concerned parties in accordance with the Grid Code.
- d. for owning the Project throughout the term of this Agreement free and clear of any encumbrances except those expressly permitted under Article 15 of this Agreement;
- e. to co-ordinate and liaise with concerned agencies and provide on a timely basis relevant information with regard to the specifications of the Project that may be required for interconnecting the Project with the Interconnection Facilities;
- f. for providing all assistance to the Arbitrators as they may require for the performance of their duties and responsibilities;
- g. to provide to the Nodal Agency and CEA, on a monthly basis, progress reports with regard to the Project and its execution (in accordance with prescribed form) to enable the CEA to monitor and co-ordinate the development of the Project matching with the Interconnection Facilities;
- h. to comply with Ministry of Power order no. 25-11/6/2018 – PG dated 02.07.2020 as well as other Guidelines issued by Govt. of India pertaining to this;
- i. to procure the products associated with the Transmission System as per provisions of Public Procurement (Preference to Make in India) orders issued by Ministry of Power vide orders No. 11/5/2018 - Coord. dated 28.07.2020 for transmission sector, as amended from time to time read with Department for Promotion of Industry and Internal Trade (DPIIT) orders in this regard (Procuring Entity as defined in above orders shall deemed to have included Selected Bidder and/ or TSP).

Also, to comply with Department of Expenditure, Ministry of Finance vide Order (Public Procurement No 1) bearing File No. 6/18/2019-PPD dated 23.07.2020, Order (Public

Procurement No 2) bearing File No. 6/18/2019-PPD dated 23.07.2020 and Order (Public Procurement No. 3) bearing File No. 6/18/2019-PPD, dated 24.07.2020, as amended from time to time, regarding public procurement from a bidder of a country, which shares land border with India;

- j. to submit to Nodal Agency information in the prescribed format [To be devised by Nodal Agency] for ensuring compliance to Article 4.1 i) above.
- k. to comply with all its obligations undertaken in this Agreement.

4.2 Roles of the Nodal Agency in implementation of the Project:

4.2.1 Subject to the terms and conditions of this Agreement, the Nodal Agency shall be the holder and administrator of this Agreement and shall inter alia:

- a. appoint an Independent Engineer within 90 days of the Effective Date
- b. provide letters of recommendation to the concerned Indian Governmental Instrumentality, as may be requested by the TSP from time to time, for obtaining the Consents, Clearances and Permits required for the Project;
- c. coordinate among TSP and upstream/downstream entities in respect of Interconnection Facilities; and
- d. monitor the implementation of the Agreement and take appropriate action for breach thereof including revocation of guarantees, cancellation of Agreement, blacklisting etc
- e. provide all assistance to the Arbitrators as required for the performance of their duties and responsibilities; and
- f. perform any other responsibility (ies) as specified in this Agreement.

4.3 Time for Commencement and Completion:

- a. The TSP shall take all necessary steps to commence work on the Project from the Effective Date of the Agreement and shall achieve Scheduled COD of the Project in accordance with the time schedule specified in Schedule 2 of this Agreement;

- b. The COD of each Element of the Project shall occur no later than the Scheduled COD or within such extended time to which the TSP shall be entitled under Article 4.4 hereto.

4.4 Extension of time:

- 4.4.1 In the event that the TSP is unable to perform its obligations for the reasons solely attributable to the Nodal Agency, the Scheduled COD shall be extended, by a 'day to day' basis, subject to the provisions of Article 13.
- 4.4.2 In the event that an Element or the Project cannot be commissioned by its Scheduled COD on account of any Force Majeure Event as per Article 11, the Scheduled COD shall be extended, by a 'day to day' basis for a period of such Force Majeure Event. Alternatively, if deemed necessary, the Nodal Agency may terminate the Agreement as per the provisions of Article 13.4 by giving a Termination Notice to the TSP, in writing, of at least seven (7) days, with a copy to CEA and the Lenders' Representative in order to enable the Lenders to exercise right of substitution in accordance with Article 15.3 of this Agreement.
- 4.4.3 If the Parties have not agreed, within thirty (30) days after the affected Party's performance has ceased to be affected by the relevant circumstance, on how long the Scheduled COD should be deferred by, any Party may raise the Dispute to be resolved in accordance with Article 16.

4.5 Metering Arrangements:

- 4.5.1 The TSP shall comply with all the provisions of the IEGC and the Central Electricity Authority (Installation and Operation of Meters) Regulations, 2006 as amended from time to time, with regard to the metering arrangements for the Project. The TSP shall fully cooperate with the CTU / STU / RLDC and extend all necessary assistance in taking meter readings.

4.6 Interconnection Facilities:

- 4.6.1 Subject to the terms and conditions of this Agreement, the TSP shall be responsible for connecting the Project with the interconnection point(s) specified in Schedule 1 of this Agreement. The Interconnection Facilities shall be developed as per the scope of work and responsibilities assigned in Schedule 1 of this Agreement. The Nodal Agency shall be responsible for coordinating to make available the Interconnection Facilities.

- 4.6.2 In order to remove any doubts, it is made clear that the obligation of the TSP within the scope of the project is to construct the Project as per Schedule-1 of this Agreement and in particular to connect it to the Interconnection Facilities as specified in this Agreement.

ARTICLE: 5**5 CONSTRUCTION OF THE PROJECT****5.1 TSP's Construction Responsibilities:**

- 5.1.1 The TSP, at its own cost and expense, shall be responsible for designing, constructing, erecting, testing and commissioning each Element of the Project by the Scheduled COD in accordance with the Regulations and other applicable Laws specified in Article 4.1 of this Agreement.
- 5.1.2 The TSP acknowledges and agrees that it shall not be relieved from any of its obligations under this Agreement or be entitled to any extension of time or any compensation whatsoever by reason of the unsuitability of the Site or Transmission Line route(s).
- 5.1.3 The TSP shall be responsible for obtaining all Consents, Clearances and Permits related but not limited to road / rail / river / canal / power line / crossings, Power and Telecom Coordination Committee (PTCC), defence, civil aviation, right of way / way-leaves and environmental & forest clearances from relevant authorities required for developing, financing, constructing, maintaining/ renewing all such Consents, Clearances and Permits in order to carry out its obligations under this Agreement in general and shall furnish to the Nodal Agency such copy/ies of each Consents, Clearances and Permits, on demand. Nodal Agency shall provide letters of recommendation to the concerned Indian Governmental Instrumentality, as may be requested by the TSP from time to time, for obtaining the Consents, Clearances and Permits required for the Project.
- 5.1.4 The TSP shall be responsible for:

- (a) **[To be deleted by the BPC in case no land acquisition is involved in the Project and replaced by "deleted"]** acquisition of land for location specific substations, switching stations or HVDC terminal or inverter stations. Also, the actual location of Greenfield substations (Switching Stations or HVDC Terminal or Inverter Stations) for a generation pooling substation and for load serving substations in the scope of TSP shall not be beyond 3 Km radius of the location proposed by the BPC in the survey report. However, actual location of any Greenfield Intermediate Substations in the scope of TSP shall not be beyond 10 Km radius of the location proposed by the BPC in the Survey Report.
- (b) **[To be deleted by the BPC in case no land acquisition is involved in the Project and replaced by "deleted"]** final selection of Site including its geo-technical investigation;
- (c) survey and geo-technical investigation of line route in order to determine the final route of the Transmission Lines;
- (d) seeking access to the Site and other places where the Project is being executed, at its own risk and costs, including payment of any crop, tree compensation or any other compensation as may be required.

5.1.5 In case the Project involves any resettlement and rehabilitation, the resettlement and rehabilitation package will be implemented by the State Government authorities, for which the costs is to be borne by the TSP and no changes would be allowed in the Transmission Charges on account of any variation in the resettlement and rehabilitation cost. The TSP shall provide assistance on best endeavour basis, in implementation of the resettlement and rehabilitation package, if execution of such package is in the interest of expeditious implementation of the Project and is beneficial to the Project affected persons.

5.2 Appointing Contractors:

5.2.1 The TSP shall conform to the requirements as provided in this Agreement while appointing Contractor(s) for procurement of goods & services.

- 5.2.2 The appointment of such Contractor(s) shall neither relieve the TSP of any of its obligations under this Agreement nor make the Nodal Agency liable for the performance of such Contractor(s).

5.3 Monthly Progress Reporting:

The TSP shall provide to the CEA, Nodal Agency & Independent Engineer, on a monthly basis, progress reports along with likely completion date of each Element with regard to the Project and its execution (in accordance with prescribed form). The Nodal Agency/ CEA shall monitor the development of the Project for its timely completion for improving and augmenting the electricity system as a part of its statutory responsibility.

5.4 Quality of Workmanship:

The TSP shall ensure that the Project is designed, built and completed in a good workmanship using sound engineering and construction practices, and using only materials and equipment that are new and manufactured as per the MQP and following approved FQP for erection, testing & commissioning and complying with Indian /International Standards such that, the useful life of the Project will be at least thirty-five (35) years from the COD of the Project.

The TSP shall ensure that all major substation equipment / component (e.g. transformers, reactors, Circuit Breakers, Instrument Transformers (IT), Surge Arresters (SA), Protection relays, clamps & connectors etc.), equipment in terminal stations of HVDC installations including Thyristor/ IGBT valves, Converter Transformers, smoothing reactors, Transformer bushings and wall bushings, GIS bus ducts, towers and gantry structures and transmission towers or poles and line materials (conductors, earthwire, OPGW, insulator, accessories for conductors, OPGW & earthwires, hardware fittings for insulators, aviation lights etc), facilities and system shall be designed, constructed and tested (Type test, Routine tests, Factory Acceptance Test (FAT)) in accordance with relevant CEA Regulations and Indian Standards. In case Indian Standards for any particular equipment/ system/ process is not available, IEC/ IEEE or equivalent International Standards and Codes shall be followed.

5.5 Progress Monitoring & Quality Assurance:

- 5.5.1 The Project Execution Plan submitted by the TSP in accordance with Article 3.1.3 c) shall comprise of detailed schedule of all the equipments/items /materials required for the Project, right from

procurement of raw material till the dispatch from works and receipt at the site. Further, it should also include various stages of the construction schedule up to the commissioning of the Project.

- 5.5.2 Nodal Agency, CEA & Independent Engineer shall have access at all reasonable times to the Site and to the Manufacturer's works and to all such places where the Project is being executed.
- 5.5.3 Independent Engineer shall ensure conformity of the conductor specifications with the functional specifications specified in RFP.
- 5.5.4 The Independent Engineer shall monitor the following during construction of the Project:
- a) Quality of equipments, material, foundation, structures and workmanship etc. as laid down in Article 5.4 and 6.1.4 of the TSA. Specifically, quality of Sub-station equipments, transmission line material and workmanship etc. would be checked in accordance with the Article 5.4.
 - b) Progress in the activities specified in Condition Subsequent
 - c) Verification of readiness of the elements including the statutory clearances & completion of civil works, fixing of all components and finalisation of punch points (if any) prior to charging of the elements
 - d) Progress of construction of substation and Transmission Lines
- 5.5.5 The progress shall be reviewed by the Independent Engineer against the Project Execution Plan. The Independent Engineer shall prepare its report on monthly basis and submit the same to Nodal Agency highlighting the progress achieved till the end of respective month vis-à-vis milestone activities, areas of concern, if any, which may result in delay in the timely completion of the Project. Based on the progress, Nodal Agency and/ or CEA shall issue written instructions to the TSP to take corrective measures, as may be prudent for the timely completion of the Project. In case of any deficiency, the Nodal Agency would be at liberty to take action in accordance with the procedure of this Agreement.
- 5.5.6 For any delay in commissioning any critical Element(s), as identified in Schedule 1 & Schedule 2 of this Agreement, beyond a period of 45 days shall lead to a sequestration of 10% of the Contract Performance Guarantee.

5.6 Site regulations and Construction Documents

The TSP shall abide by the Safety Rules and Procedures as mentioned in Schedule 3 of this Agreement

The TSP shall retain at the Site and make available for inspection at all reasonable times, copies of the Consents, Clearances and Permits, construction drawings and other documents related to construction.

5.7 Supervision of work:

The TSP shall provide all necessary superintendence for execution of the Project and its supervisory personnel shall be available to provide full-time superintendence for execution of the Project. The TSP shall provide skilled personnel who are experienced in their respective fields.

5.8 Remedial Measures:

The TSP shall take all necessary actions for remedying the shortfall in achievement of timely progress in execution of the Project, if any, as intimated by the Independent Engineer and/ or CEA and/ or the Nodal Agency. However, such intimation by the Independent Engineer and/ or CEA and/ or the Nodal Agency and the subsequent effect of such remedial measures carried out by the TSP shall not relieve the TSP of its obligations in the Agreement. Independent Engineer and/ or CEA and/ or the Nodal Agency may carry out random inspections during the Project execution, as and when deemed necessary by it. If the shortfalls as intimated to the TSP are not remedied to the satisfaction of the CEA and/ or the Nodal Agency, this Agreement may be terminated by the Nodal Agency by giving a Termination Notice to the TSP, in writing, of at least seven (7) days, with a copy to CEA and the Lenders' Representative in order to enable the Lenders to exercise right of substitution in accordance with Article 15.3 of this Agreement.

ARTICLE: 6**6 CONNECTION AND COMMISSIONING OF THE PROJECT****6.1 Connection with the Inter-Connection Facilities:**

- 6.1.1 The TSP shall give the RLDC(s), CTU, / STU, as the case may be, and any other agencies as required, at least sixty (60) days advance written notice of the date on which it intends to connect an Element of the Project, which date shall not be earlier than its Scheduled COD or Schedule COD extended as per Article 4.4.1 & 4.4.2 of this Agreement, unless mutually agreed to by Parties. Further, any preponing of COD of any element prior to Scheduled COD must be approved by the Nodal Agency.
- 6.1.2 The RLDC / SLDC (as the case may be) or the CTU / STU (as the case may be), for reasonable cause, including non-availability of Interconnection Facilities as per Article 4.2, can defer the connection for up to fifteen (15) days from the date notified by the TSP pursuant to Article 6.1.1, if it notifies to the TSP in writing, before the date of connection, of the reason for the deferral and when the connection is to be rescheduled. However, no such deferment on one or more occasions would be for more than an aggregate period of thirty (30) days. Further, the Scheduled COD would be extended as required, for all such deferments on “day to day” basis.
- 6.1.3 Subject to Articles 6.1.1 and 6.1.2, any Element of Project may be connected with the Interconnection Facilities when:
- a. it has been completed in accordance with this Agreement and the Connection Agreement;
 - b. it meets the Grid Code, Central Electricity Authority (Technical Standards for Connectivity to the Grid) Regulations, 2007 as amended from time to time and all other Indian legal requirements, and
 - c. The TSP has obtained the approval in writing of the Electrical Inspector certifying that the Element is ready from the point of view of safety of supply and can be connected with the Interconnection Facilities.
 - d. It has satisfactorily met all the testing requirements as per Articles 6.1.4

- 6.1.4 Site Acceptance Test (SAT)/ pre-commissioning tests of all major substation equipment, component, system, facilities shall be successfully carried out before commissioning. The Type tests, FAT and SAT reports should be available at the substation / terminal station of HVDC installations for ready reference of operation and maintenance staff and has to be made available to the Independent Engineer appointed for quality monitoring or their authorised representatives, as and when they wish to examine the same.

6.2 Commercial Operation:

- 6.2.1 An Element of the Project shall be declared to have achieved COD twenty four (24) hours following the connection of the Element with the Interconnection Facilities pursuant to Article 6.1 or seven (7) days after the date on which it is declared by the TSP to be ready for charging but is not able to be charged for reasons not attributable to the TSP subject to Article 6.1.2.

Provided that an Element shall be declared to have achieved COD only after all the Element(s), if any, which are pre-required to have achieved COD as defined in Schedule 2 of this Agreement, have been declared to have achieved their respective COD.

- 6.2.2 Once any Element of the Project has been declared to have achieved deemed COD as per Article 6.2.1 above, such Element of the Project shall be deemed to have Availability equal to the Target Availability till the actual charging of the Element and to this extent, TSP shall be eligible for the Monthly Transmission Charges applicable for such Element

6.3 Compensation for Direct Non Natural Force Majeure Event or Indirect Non Natural Force Majeure Event or Natural Force Majeure Event (affecting the Nodal Agency)

- 6.3.1 If the TSP is otherwise ready to connect the Element(s) of the Project and has given due notice, as per provisions of Article 6.1.1, to the concerned agencies of the date of intention to connect the Element(s) of the Project, where such date is not before the Scheduled COD, but is not able to connect the Element(s) of the Project by the said date specified in the notice, due to Direct Non Natural Force Majeure Event or Indirect Non Natural Force Majeure Event or Natural Force Majeure Event affecting the Nodal Agency, provided such Direct Non Natural Force Majeure Event or Indirect Non Natural Force Majeure Event or Natural

Force Majeure Event affecting the Nodal Agency has continued for a period of more than three (3) continuous or non-continuous Months, the TSP shall, until the effects of the Direct Non Natural Force Majeure Event or of Indirect Non Natural Force Majeure Event or Natural Force Majeure Event affecting the Nodal Agency no longer prevent the TSP from connecting the Element(s) of the Project, be deemed to have achieved COD relevant to that date and to this extent, be deemed to have been providing Transmission Service with effect from the date notified, and shall be treated as follows:

- a. In case of delay due to Direct Non Natural Force Majeure Event, TSP is entitled for Transmission Charges calculated on Target Availability for the period of such events in excess of three (3) continuous or non-continuous Months in the manner provided in (c) below.
- b. In case of delay due to Indirect Non Natural Force Majeure Event or Natural Force Majeure Event affecting the Nodal Agency, TSP is entitled for payment for debt service which is due under the Financing Agreements, subject to a maximum of Transmission Charges calculated on Target Availability, for the period of such events in excess of three (3) continuous or non-continuous Months in the manner provided in (c) below.
- c. In case of delay due to Direct Non Natural Force Majeure Event or Indirect Non Natural Force Majeure Event or Natural Force Majeure Event affecting the Nodal Agency, the TSP is entitled for payments mentioned in (a) and (b) above, after commencement of Transmission Service, in the form of an increase in Transmission Charges. These amounts shall be paid from the date, being the later of a) the date of cessation of such Indirect Non Natural Force Majeure Event or Natural Force Majeure Event affecting the Nodal Agency and b) the completion of sixty (60) days from the receipt of the Financing Agreements by the Nodal Agency from the TSP.

Provided such increase in Transmission Charges shall be so as to put the TSP in the same economic position as the TSP would have been in case the TSP had been paid amounts mentioned in (a) and (b) above in a situation where the Force Majeure Event had not occurred.

For the avoidance of doubt, it is clarified that the charges payable under this Article 6.3.1 shall be recovered as per Sharing Regulations.

6.4 Liquidated Damages for Delay in achieving COD of Project:

6.4.1 If the TSP fails to achieve COD of any Element of the Project or the Project, by the Element's / Project's Scheduled COD or such Scheduled COD as extended under Articles 4.4.1 and 4.4.3, then the TSP shall pay to the Nodal Agency, a sum equivalent to 3.33% of Monthly Transmission Charges applicable for the Element of the Project [in case where no Elements have been defined, to be on the Project as a whole] / Project, for each day of delay up to sixty (60) days of delay and beyond that time limit, at the rate of five percent (5%) of the Monthly Transmission Charges applicable to such Element / Project, as liquidated damages for such delay and not as penalty, without prejudice to any rights of the Nodal Agency under the Agreement.

6.4.2 The TSP's maximum liability under this Article 6.4 shall be limited to the amount of liquidated damages calculated in accordance with Article 6.4.1 for and up to six (6) months of delay for the Element or the Project.

Provided that, in case of failure of the TSP to achieve COD of the Element of the Project even after the expiry of six (6) months from its Scheduled COD, the provisions of Article 13 shall apply.

6.4.3 The TSP shall make payment to the Nodal Agency of the liquidated damages calculated pursuant to Article 6.4.1 within ten (10) days of the earlier of:

- a. the date on which the applicable Element achieves COD; or
- b. the date of termination of this Agreement.

The payment of such damages shall not relieve the TSP from its obligations to complete the Project or from any other obligation and liabilities under the Agreement.

6.4.4 If the TSP fails to pay the amount of liquidated damages to the Nodal Agency within the said period of ten (10) days, the Nodal Agency shall be entitled to recover the said amount of the liquidated damages by invoking the Contract Performance Guarantee. If the then existing Contract Performance Guarantee is for an amount which is less than the amount of the liquidated damages payable by the TSP to the Nodal Agency under this Article 6.3 and the TSP fails to make payment of the balance amount of the liquidated damages not covered by the Contract Performance Guarantee, then such balance amount shall be deducted from the Transmission Charges payable to the TSP. The right of the

Nodal Agency to encash the Contract Performance Guarantee is without prejudice to the other rights of the Nodal Agency under this Agreement.

- 6.4.5 For avoidance of doubt, it is clarified that amount payable by TSP under this Article is over and above the penalty payable by TSP under Article 5.5.6 of this Agreement.

6.5 Return of Contract Performance Guarantee

- 6.5.1 The Contract Performance Guarantee as submitted by TSP in accordance with Article 3.1.1 shall be released by the Nodal Agency within three (3) months from the COD of the Project. In the event of delay in achieving Scheduled COD of any of the Elements by the TSP (otherwise than due to reasons as mentioned in Article 3.1.3 or Article 11) and consequent part invocation of the Contract Performance Guarantee by the Nodal Agency, Nodal Agency shall release the Contract Performance Guarantee, if any remaining unadjusted, after the satisfactory completion by the TSP of all the requirements regarding achieving the Scheduled COD of the remaining Elements of the Project. It is clarified that the Nodal Agency shall also return / release the Contract Performance Guarantee in the event of (i) applicability of Article 3.3.2 to the extent the Contract Performance Guarantee is valid for an amount in excess of Rs. 3.0 Crore (Rupees Three Crore only), or (ii) termination of this Agreement by the Nodal Agency as mentioned under Article 3.3.4 of this Agreement.
- 6.5.2 The release of the Contract Performance Guarantee shall be without prejudice to other rights of the Nodal Agency under this Agreement.

ARTICLE: 7**7 OPERATION AND MAINTENANCE OF THE PROJECT****7.1 Operation and Maintenance of the Project:**

The TSP shall be responsible for ensuring that the Project is operated and maintained in accordance with the regulations made by the Commission and CEA from time to time and provisions of the Act.

ARTICLE: 8**8 AVAILABILITY OF THE PROJECT****8.1 Calculation of Availability of the Project:**

Calculation of Availability for the Elements and for the Project, as the case may be, shall be as per Appendix –II to Central Electricity Regulatory Commission (Terms and Conditions of Tariff) Regulations, 2019, as applicable on the Bid Deadline and as appended in Schedule 6 of this Agreement.

8.2 Target Availability:

The Target Availability of each Element and the Project shall be 98%.

Payment of monthly Transmission charges based on actual availability will be calculated as per para 1.2 of Schedule 4 of this Agreement.

If the availability of any Element or the Project is below the Target Availability, for six consecutive months in a Contract Year, the DIC(s) or the Nodal Agency may issue a show cause notice to the TSP, asking them to show cause as to why the Transmission Service Agreement be not terminated, and if no satisfactory cause is shown it may terminate the Agreement. If the Nodal Agency is of the opinion that the transmission system is of critical importance, it may carry out or cause to carry the operation and maintenance of transmission system at the risk and cost of TSP.

ARTICLE: 9**9 INSURANCES****9.1 Insurance:**

9.1.1 The TSP shall effect and maintain or cause to be effected and maintained during the Construction Period and the Operating Period, adequate Insurances against such risks, with such deductibles including but not limited to any third party liability and endorsements and co-beneficiary/insured, as may be necessary under

- a. any of the Financing Agreements,
- b. the Laws, and
- c. in accordance with Prudent Utility Practices.

The Insurances shall be taken effective from a date prior to the date of the Financial Closure till the Expiry Date.

9.2 Evidence of Insurance cover:

9.2.1 The TSP shall furnish to the Nodal Agency copies of certificates and policies of the Insurances, as and when the Nodal Agency may seek from the TSP as per the terms of Article 9.1

9.3 Application of Insurance Proceeds:

9.3.1 Save as expressly provided in this Agreement, the policies of Insurances and the Financing Agreements, the proceeds of any insurance claim made due to loss or damage to the Project or any part of the Project shall be first applied to reinstatement, replacement or renewal of such loss or damage.

9.3.2 If a Natural Force Majeure Event renders the Project no longer economically and technically viable and the insurers under the Insurances make payment on a "total loss" or equivalent basis, the portion of the proceeds of such Insurance available to the TSP (after making admissible payments to the Lenders as per the Financing Agreements) shall be allocated only to the TSP. Nodal Agency and / or concerned Designated ISTS Customers shall have no claim on such proceeds of the Insurance.

9.3.3 Subject to the requirements of the Lenders under the Financing

Agreements, any dispute or difference between the Parties as to whether the Project is no longer economically and technically viable due to a Force Majeure Event or whether that event was adequately covered in accordance with this Agreement by the Insurances shall be determined in accordance with Article 16.

9.4 Effect on liability of the Nodal Agency / Designated ISTS Customers

9.4.1 The Nodal Agency and / or the Designated ISTS Customers shall have no financial obligations or liability whatsoever towards the TSP in respect of this Article 9.

ARTICLE: 10**10 BILLING AND PAYMENT OF TRANSMISSION CHARGES**

10.1 Subject to provisions of this Article 10, the Monthly Transmission Charges shall be paid to the TSP, in Indian Rupees, on monthly basis as per the provisions of the Sharing Regulations, from the date on which an Element(s) has achieved COD until the Expiry Date of this Agreement, unless terminated earlier and in line with the provisions of Schedule 4 of this Agreement.

10.2 Calculation of Monthly Transmission Charges:

The Monthly Transmission Charges for each Contract Year including Incentive & Penalty payment shall be calculated in accordance with the provisions of Schedule 4 of this Agreement.

10.3 Rebate & Late Payment Surcharge:

The rebate and late payment surcharge shall be governed as per Sharing Regulations.

10.4 Disputed Bills, Default in payment by the Designated ISTS Customers & Annual Reconciliation:

Any Disputed Bill, Default in payment by the Designated ISTS Customers & Annual Reconciliation shall be governed as per Sharing Regulations.

ARTICLE: 11**11 FORCE MAJEURE****11.1 Definitions**

11.1.1 The following terms shall have the meanings given hereunder.

11.2 Affected Party

11.2.1 An Affected Party means any Party whose performance has been affected by an event of Force Majeure.

11.2.2 Any event of Force Majeure shall be deemed to be an event of Force Majeure affecting the TSP only if the Force Majeure event affects and results in, late delivery of machinery and equipment for the Project or construction, completion, commissioning of the Project by Scheduled COD and/or operation thereafter;

11.3 Force Majeure

A 'Force Majeure' means any event or circumstance or combination of events and circumstances including those stated below that wholly or partly prevents or unavoidably delays an Affected Party in the performance of its obligations/ roles under this Agreement, but only if and to the extent that such events or circumstances are not within the reasonable control, directly or indirectly, of the Affected Party and could not have been avoided if the Affected Party had taken reasonable care or complied with Prudent Utility Practices:

(a) Natural Force Majeure Events:

- i. act of God, including, but not limited to drought, fire and explosion (to the extent originating from a source external to the Site), earthquake, volcanic eruption, landslide, flood, cyclone, typhoon, tornado, or exceptionally adverse weather conditions, which are in excess of the statistical measures for the last hundred (100) years; and
- ii. epidemic/ pandemic notified by Indian Governmental Instrumentality.

(b) Non-Natural Force Majeure Events :

- i. Direct Non-Natural Force Majeure Events

- Nationalization or compulsory acquisition by any Indian Governmental Instrumentality of any material assets or rights of the Affected Party; or
 - the unlawful, unreasonable or discriminatory revocation of, or refusal to renew, any Consents, Clearances and Permits required by the Affected Party to perform their obligations/ roles under the RFP Project Documents or any unlawful, unreasonable or discriminatory refusal to grant any other Consents, Clearances and Permits required for the development/ operation of the Project, provided that a Competent Court of Law declares the revocation or refusal to be unlawful, unreasonable and discriminatory and strikes the same down; or
 - any other unlawful, unreasonable or discriminatory action on the part of an Indian Governmental Instrumentality which is directed against the Project, provided that a Competent Court of Law declares the action to be unlawful, unreasonable and discriminatory and strikes the same down.
- ii. Indirect Non - Natural Force Majeure Events
- act of war (whether declared or undeclared), invasion, armed conflict or act of foreign enemy, blockade, embargo, revolution, riot, insurrection, terrorist or military action; or
 - radioactive contamination or ionising radiation originating from a source in India or resulting from any other Indirect Non Natural Force Majeure Event mentioned above, excluding circumstances where the source or cause of contamination or radiation is brought or has been brought into or near the Site by the Affected Party or those employed or engaged by the Affected Party; or
 - industry-wide strikes and labour disturbances, having a nationwide impact in India.

11.4 Force Majeure Exclusions

- 11.4.1 Force Majeure shall not include (i) any event or circumstance which is within the reasonable control of the Parties and (ii) the following conditions, except to the extent that they are consequences of an event

of Force Majeure:

- (a) Unavailability, late delivery, or changes in cost of the machinery, equipment, materials, spare parts etc. for the Project;
- (b) Delay in the performance of any Contractors or their agents;
- (c) Non-performance resulting from normal wear and tear typically experienced in transmission materials and equipment;
- (d) Strikes or labour disturbance at the facilities of the Affected Party;
- (e) Insufficiency of finances or funds or the Agreement becoming onerous to perform; and
- (f) Non-performance caused by, or connected with, the Affected Party's:
 - i. negligent or intentional acts, errors or omissions;
 - ii. failure to comply with an Indian Law; or
 - iii. breach of, or default under this Agreement or any Project Documents.
- (g) Any error or omission in the survey report provided by BPC during the bidding process.

11.5 Notification of Force Majeure Event

11.5.1 The Affected Party shall give notice to the other Party of any event of Force Majeure as soon as reasonably practicable, but not later than seven (7) days after the date on which such Party knew or should reasonably have known of the commencement of the event of Force Majeure. If an event of Force Majeure results in a breakdown of communications rendering it unreasonable to give notice within the applicable time limit specified herein, then the Party claiming Force Majeure shall give such notice as soon as reasonably practicable after reinstatement of communications, but not later than one (1) day after such reinstatement.

Provided that, such notice shall be a pre-condition to the Affected Party's entitlement to claim relief under this Agreement. Such notice shall include full particulars of the event of Force Majeure, its effects on the Party claiming relief and the remedial measures proposed. The Affected

Party shall give the other Party regular reports on the progress of those remedial measures and such other information as the other Party may reasonably request about the Force Majeure.

- 11.5.2 The Affected Party shall give notice to the other Party of (i) the cessation of the relevant event of Force Majeure; and (ii) the cessation of the effects of such event of Force Majeure on the performance of its rights or obligations/ roles under this Agreement, as soon as practicable after becoming aware of each of these cessations.

11.6 Duty to perform and duty to mitigate

To the extent not prevented by a Force Majeure Event, the Affected Party shall continue to perform its obligations/ roles as provided in this Agreement. The Affected Party shall use its reasonable efforts to mitigate the effect of any event of Force Majeure as soon as practicable.

11.7 Available Relief for a Force Majeure Event

Subject to this Article 11,

- (a) no Party shall be in breach of its obligations/ roles pursuant to this Agreement to the extent that the performance of its obligations/ roles was prevented, hindered or delayed due to a Force Majeure Event;
- (b) each Party shall be entitled to claim relief for a Force Majeure Event affecting its performance in relation to its obligations/ roles under Articles 3.3.4, 4.4.2 and 6.3.1 of this Agreement.
- (c) For the avoidance of doubt, it is clarified that the computation of Availability of the Element(s) under outage due to Force Majeure Event, as per Article 11.3 affecting the TSP shall be as per Appendix –II to Central Electricity Regulatory Commission (Terms and Conditions of Tariff) Regulations, 2019 as on Bid Deadline. For the event(s) for which the Element(s) is/are deemed to be available as per Appendix –II to Central Electricity Regulatory Commission (Terms and Conditions of Tariff) Regulations, 2019, then the Transmission Charges, as applicable to such Element(s), shall be payable as per Schedule 4, for the duration of such event(s).
- (d) For so long as the TSP is claiming relief due to any Force Majeure Event under this Agreement, the Nodal Agency may, if it so desires, from time to time on one (1) day notice, inspect the Project and the

TSP shall provide the Nodal Agency's personnel with access to the Project to carry out such inspections.

- (e) For avoidance of doubt, the TSP acknowledges that for extension of Scheduled COD a period up to one hundred eighty (180) days due to Force Majeure event, no compensation on the grounds such as interest cost, incident expenditure, opportunity cost will be made to the TSP. However, if Scheduled COD is extended beyond a period of one hundred eighty (180) days due to Force Majeure event, the TSP will be allowed to recover the interest cost during construction corresponding to the period exceeding one hundred eighty (180) days by adjustment in the Transmission Charges in accordance with Schedule 9.

ARTICLE: 12**12 CHANGE IN LAW****12.1 Change in Law**

12.1.1 Change in Law means the occurrence of any of the following after the Bid Deadline resulting into any additional recurring / non-recurring expenditure by the TSP or any savings of the TSP:

- the enactment, coming into effect, adoption, promulgation, amendment, modification or repeal (without re-enactment or consolidation) in India, of any Law, including rules and regulations framed pursuant to such Law, subject to the provisions under Article 12.1.2;
- a change in the interpretation or application of any Law by any Indian Governmental Instrumentality having the legal power to interpret or apply such Law, or any Competent Court of Law;
- the imposition of a requirement for obtaining any Consents, Clearances and Permits which was not required earlier;
- a change in the terms and conditions prescribed for obtaining any Consents, Clearances and Permits or the inclusion of any new terms or conditions for obtaining such Consents, Clearances and Permits;
- any change in the licensing regulations of the Commission, under which the Transmission License for the Project was granted if made applicable by such Commission to the TSP;
- change in wind zone; or
- any change in tax or introduction of any tax made applicable for providing Transmission Service by the TSP as per the terms of this Agreement.

12.1.2 Notwithstanding anything contained in this Agreement, Change in Law shall not cover any change:

- a) Taxes on corporate income; and
- b) Withholding tax on income or dividends distributed to the shareholders of the TSP.

12.2 Relief for Change in Law

12.2.1 During Construction Period, the impact of increase/decrease in the cost of the Project on the Transmission Charges shall be governed by the formula given in Schedule 9 of this Agreement.

12.2.2 During the Operation Period:

During the operation period, if as a result of Change in Law, the TSP suffers or is benefited from a change in costs or revenue, the aggregate financial effect of which exceeds 0.30% (zero point three percent) of the Annual Transmission Charges in aggregate for a Contract Year, the TSP may notify so to the Nodal Agency and propose amendments to this Agreement so as to place the TSP in the same financial position as it would have enjoyed had there been no such Change in Law resulting in change in costs or revenue as aforesaid.

12.2.3 For any claims made under Articles 12.2.1 and 12.2.2 above, the TSP shall provide to the Nodal Agency documentary proof of such increase / decrease in cost of the Project / revenue for establishing the impact of such Change in Law.

In cases where Change in Law results in decrease of cost and it comes to the notice of Nodal Agency that TSP has not informed Nodal Agency about such decrease in cost, Nodal Agency may initiate appropriate claim.

12.3 Notification of Change in Law:

- 12.3.1 If the TSP is affected by a Change in Law in accordance with Article 12.1 and wishes to claim relief for such Change in Law under this Article 12, it shall give notice to Nodal Agency of such Change in Law as soon as reasonably practicable after becoming aware of the same.
- 12.3.2 The TSP shall also be obliged to serve a notice to the Nodal Agency even when it is beneficially affected by a Change in Law.
- 12.3.3 Any notice served pursuant to Articles 12.3.1 and 12.3.2 shall provide, amongst other things, precise details of the Change in Law and its estimated impact on the TSP.

12.4 Payment on account of Change in Law

- 12.4.1 The payment for Change in Law shall be through a separate Bill. However, in case of any change in Monthly Transmission Charges by reason of Change in Law, as determined in accordance with this Agreement, the Bills to be raised by the Nodal Agency after such change in Transmission Charges shall appropriately reflect the changed Monthly Transmission Charges.

ARTICLE: 13**13 EVENTS OF DEFAULT AND TERMINATION****13.1 TSP's Event of Default**

The occurrence and continuation of any of the following events shall constitute a TSP Event of Default, unless any such TSP Event of Default occurs as a result of any non-fulfilment of its obligations as prescribed under this Agreement by the Nodal Agency or a Force Majeure Event:

- a. After having taken up the construction of the Project, the abandonment by the TSP or the TSP's Contractors of the construction of the Project for a continuous period of two (2) months and such default is not rectified within thirty (30) days from the receipt of notice from the Nodal Agency in this regard;
- b. The failure to commission any Element of the Project by the date falling six (6) months after its Scheduled COD unless extended by Nodal Agency as per provisions of this Agreement;
- c. If the TSP:
 - i. assigns, mortgages or charges or purports to assign, mortgage or charge any of its assets or rights related to the Project in contravention of the provisions of this Agreement; or
 - ii. transfers or novates any of its obligations pursuant to this Agreement, in a manner contrary to the provisions of this Agreement;

Except where such transfer is in pursuance of a Law and

- it does not affect the ability of the transferee to perform, and such transferee has the financial and technical capability to perform, its obligations under this Agreement;
- is to a transferee who assumes such obligations under the Project and this Agreement remains effective with respect to the transferee;

- d. If:
- i. The TSP becomes voluntarily or involuntarily the subject of any bankruptcy or insolvency or winding up proceedings and such proceedings remain uncontested for a period of thirty (30) days; or
 - ii. any winding up or bankruptcy or insolvency order is passed against the TSP; or
 - iii. the TSP goes into liquidation or dissolution or a receiver or any similar officer is appointed over all or substantially all of its assets or official liquidator is appointed to manage its affairs, pursuant to Law,

Provided that a dissolution or liquidation of the TSP will not be a TSP's Event of Default, where such dissolution or liquidation of the TSP is for the purpose of a merger, consolidation or reorganization with the prior approval of the Commission as per the provisions of Central Electricity Regulatory Commission (Procedure, terms and Conditions for grant of Transmission License and other related matters) Regulations, 2006 or as amended from time to time; or
- e. Failure on the part of the TSP to comply with the provisions of Article 19.1 of this Agreement; or
- f. the TSP repudiates this Agreement and does not rectify such breach even within a period of thirty (30) days from a notice from the Nodal Agency in this regard; or
- g. after Commercial Operation Date of the Project, the TSP fails to achieve monthly Target Availability of 98%, for a period of six (6) consecutive months or within a non-consecutive period of six (6) months within any continuous aggregate period of eighteen(18) months except where the Availability is affected by Force Majeure Events as per Article 11; or
- h. any of the representations and warranties made by the TSP in Article 17 of this Agreement being found to be untrue or inaccurate. Further, in addition to the above, any of the undertakings submitted by the Selected Bidder at the time of submission of the Bid being found to be breached or inaccurate, including but not limited to undertakings from its

Parent Company / Affiliates related to the minimum equity obligation; or

- i. the TSP fails to complete / fulfil all the activities / conditions within the specified period as per Article 3; or
- j. except for the reasons solely attributable to Nodal Agency, the TSP is in material breach of any of its obligations under this Agreement and such material breach is not rectified by the TSP within thirty (30) days of receipt of notice in this regard from the Nodal Agency; or
- k. deleted.

13.2 Termination Procedure for TSP Event of Default

- a. Upon the occurrence and continuance of any TSP's Event of Default under Article 13.1 the Nodal Agency may serve notice on the TSP, with a copy to the CEA and the Lenders' Representative, of their intention to terminate this Agreement (a "Nodal Agency's Preliminary Termination Notice"), which shall specify in reasonable detail, the circumstances giving rise to such Nodal Agency's Preliminary Termination Notice.
- b. Following the issue of a Nodal Agency's Preliminary Termination Notice, the Consultation Period shall apply and would be for the Parties to discuss as to what steps shall be taken with a view to mitigate the consequences of the relevant Event of Default having regard to all the circumstances.
- c. During the Consultation Period, the Parties shall, save as otherwise provided in this Agreement, continue to perform their respective obligations/ roles under this Agreement, and the TSP shall not remove any material, equipment or any part of the Project, without prior consent of the Nodal Agency.

Following the expiry of the Consultation Period, unless the Parties shall have otherwise agreed to the contrary or the circumstances giving rise to Nodal Agency's Preliminary Termination Notice shall have ceased to exist or shall have been remedied, this Agreement may be terminated by the Nodal Agency by giving a Termination Notice to the TSP, in writing, of at least seven (7) days, with a copy to CEA and the Lenders' Representative in order to enable the Lenders to exercise right of substitution in accordance with Article 15.3 of this Agreement.

Further, the Nodal Agency may also initiate proceedings to blacklist the TSP & its Affiliates from participation in any RFP issued by BPCs for a period of 5 years.

13.3 Procedure for Nodal Agency's non-fulfilment of Role

- a. Upon the Nodal Agency not being able to fulfil its role under Article 4.2, the TSP may serve notice on the Nodal Agency, with a copy to CEA and the Lenders' Representative (a "TSP's Preliminary Notice"), which notice shall specify in reasonable detail the circumstances giving rise to such non-fulfilment of role by the Nodal Agency.
- b. Following the issue of a TSP's Preliminary Notice, the Consultation Period shall apply.
- c. The Consultation Period would be for the Parties to discuss as to what steps shall be taken with a view to mitigate the consequences of the relevant non-fulfilment of role by the Nodal Agency including giving time extension to TSP, having regard to all the circumstances.
- d. During the Consultation Period, both Parties shall, save as otherwise provided in this Agreement, continue to perform their respective obligations/ roles under this Agreement.

13.4 Termination due to Force Majeure

- 13.4.1 In case the Parties could not reach an agreement pursuant to Articles 3.3.4 and 4.4.2 of this Agreement and the Force Majeure Event or its effects continue to be present, the Nodal Agency shall have the right to cause termination of the Agreement. In case of such termination, the Contract Performance Guarantee shall be returned to the TSP as per the provisions of Article 6.5.1.

13.4.2 In case of termination of this Agreement, the TSP shall provide to the Nodal Agency the full names and addresses of its Contractors as well as complete designs, design drawings, manufacturing drawings, material specifications and technical information, as required by the Nodal Agency within thirty (30) days of Termination Notice.

13.5 Termination or amendment due to non-requirement of any Element or Project during construction

13.5.1 In case any Element or Project, which is under construction, is no longer required due to any reason whatsoever, the Nodal Agency may issue a notice to this effect to the TSP.

13.5.2 Nodal agency may also issue notice to the TSP seeking their response to the proposed termination/ amendment (as the case may be) of the Agreement. The Nodal Agency shall issue copy of such notice to Lenders. In the notice, Nodal Agency shall also include an assessment of the physical progress made by TSP in the Element/ Project (as the case may be) that is no longer required.

13.5.3 The TSP shall neither carry out further investment nor carry out any work on the Element/ Project (as the case may be) that is no longer required after delivery of the notice.

13.5.4 After taking into account the comments of the TSP, the Nodal Agency may terminate the Agreement or amend it if both Parties agree to the amendment.

13.6 Revocation of the Transmission License

13.6.1 The Commission may, as per the provisions of the Electricity Act, 2003, revoke the Transmission License of the ISTS Licensee. Further, in such a case, the Agreement shall be deemed to have been terminated.

13.7 Termination Payment

13.7.1 If Agreement is terminated on account of Force Majeure Events, non-requirement of any Element or Project during Construction, Nodal Agency's non-fulfilment of Role & TSP's Event of Default, the TSP shall be entitled for Termination Payment equivalent to valuation of Project Assets. Upon payment, the Nodal Agency shall take over the Project Assets.

ARTICLE: 14**14 LIABILITY AND INDEMNIFICATION****14.1 Indemnity**

14.1.1 The TSP shall indemnify, defend and hold the Nodal Agency harmless against:

- (a) any and all third party claims, actions, suits or proceedings against the Nodal Agency for any loss of or damage to property of such third party, or death or injury to such third party, arising out of a breach by the TSP of any of its obligations under this Agreement, except to the extent that any such claim, action, suit or proceeding has arisen due to a negligent act or omission, breach of this Agreement or non-fulfilment of statutory duty on the part of Nodal Agency; and
- (b) any and all losses, damages, costs and expenses including legal costs, fines, penalties and interest actually suffered or incurred by the Nodal Agency from third party claims arising by reason of:
 - i. a breach by the TSP of any of its obligations under this Agreement, (provided that this Article 14 shall not apply to such breaches by the TSP, for which specific remedies have been provided for under this Agreement) except to the extent that any such losses, damages, costs and expenses including legal costs, fines, penalties and interest (together to constitute "Indemnifiable Losses") has arisen due to a negligent act or omission, breach of this Agreement or non-fulfilment of statutory duty on the part of the Nodal Agency, or
 - ii. any of the representations and warranties of the TSP under this Agreement being found to be inaccurate or untrue.

14.1.2 The Nodal Agency shall, in accordance with the Regulations framed by CERC in this regard, indemnify, defend and hold the TSP harmless against:

- (a) any and all third party claims, actions, suits or proceedings against the TSP, for any loss of or damage to property of such third party, or death or injury to such third party, arising out of any material breach by the Nodal Agency of any of their roles under this

Agreement, except to the extent that any such claim, action, suit or proceeding has arisen due to a negligent act or omission, breach of this Agreement or breach of statutory duty on the part of the TSP, its Contractors, servants or agents; and

- (b) any and all losses, damages, costs and expenses including legal costs, fines, penalties and interest ('Indemnifiable Losses') actually suffered or incurred by the TSP from third party claims arising by reason of:
 - i. any material breach by the Nodal Agency of any of its roles under this Agreement (provided that, this Article 14 shall not apply to such breaches by the Nodal Agency, for which specific remedies have been provided for under this Agreement), except to the extent that any such Indemnifiable Losses have arisen due to a negligent act or omission, breach of this Agreement or breach of statutory duty on the part of the TSP, its Contractors, servants or agents or
 - ii. any of the representations and warranties of the Nodal Agency under this Agreement being found to be inaccurate or untrue.

14.2 Patent Indemnity:

14.2.1

- (a) The TSP shall, subject to the Nodal Agency's compliance with Article 14.2.1 (b), indemnify and hold harmless the Nodal Agency and its employees and officers from and against any and all suits, actions or administrative proceedings, claims, demands, losses, damages, costs, and expenses of whatsoever nature, including attorney's fees and expenses, which the Nodal Agency may suffer as a result of any infringement or alleged infringement of any patent, utility model, registered design, trademark, copyright or other intellectual property right registered or otherwise existing at the date of the Agreement by reason of the setting up of the Project by the TSP.

Such indemnity shall not cover any use of the Project or any part thereof other than for the purpose indicated by or to be reasonably inferred from the Agreement, any infringement resulting from the misuse of the Project or any part thereof, or any products produced in association or combination with any other equipment, plant or

materials not supplied by the TSP, pursuant to the Agreement.

- (b) If any proceedings are brought or any claim is made against the Nodal Agency arising out of the matters referred to in Article 14.2.1(a), the Nodal Agency shall promptly give the TSP a notice thereof, and the TSP shall at its own expense take necessary steps and attend such proceedings or claim and any negotiations for the settlement of any such proceedings or claim. The TSP shall promptly notify the Nodal Agency of all actions taken in such proceedings or claims.
- (c) If the TSP fails to notify the Nodal Agency within twenty-eight (28) days after receipt of such notice from the Nodal Agency under Article 14.2.1(b) above, that it intends to attend any such proceedings or claim, then the Nodal Agency shall be free to attend the same on their own behalf at the cost of the TSP. Unless the TSP has so failed to notify the Nodal Agency within the twenty eight (28) days period, the Nodal Agency shall make no admission that may be prejudicial to the defence of any such proceedings or claims.
- (d) The Nodal Agency shall, at the TSP's request, afford all available assistance to the TSP in attending to such proceedings or claim, and shall be reimbursed by the TSP for all reasonable expenses incurred in so doing.

14.2.2

- (a) The Nodal Agency, in accordance with the Regulations framed by CERC in this regard, subject to the TSP's compliance with Article 14.2.2(b) shall indemnify and hold harmless the TSP and its employees, officers from and against any and all suits, actions or administrative proceedings, claims, demands, losses, damages, costs and expenses of whatsoever nature, including attorney's fees and expenses, which the TSP may suffer as a result of any infringement or alleged infringement of any patent, utility model, registered design, trademark, copyright or other intellectual property right registered or otherwise existing at the date of the Agreement by reason of the setting up of the Project by the TSP.
- (b) If any proceedings are brought or any claim is made against the TSP arising out of the matters referred to in Article 14.2.2 (a) the TSP shall promptly give the Nodal Agency a notice thereof, and the

Nodal Agency shall at its own expense take necessary steps and attend such proceedings or claim and any negotiations for the settlement of any such proceedings or claim. The Nodal Agency shall promptly notify the TSP of all actions taken in such proceedings or claims.

- (c) If the Nodal Agency fails to notify the TSP within twenty-eight (28) days after receipt of such notice from the TSP under Article 14.2.2(b) above, that it intends to attend any such proceedings or claim, then the TSP shall be free to attend the same on its own behalf at the cost of the Nodal Agency. Unless the Nodal Agency has so failed to notify the TSP within the twenty (28) days period, the TSP shall make no admission that may be prejudicial to the defence of any such proceedings or claim.
- (d) The TSP shall, at the Nodal Agency request, afford all available assistance to the Nodal Agency in attending to such proceedings or claim, and shall be reimbursed by the Nodal Agency for all reasonable expenses incurred in so doing.

14.3 Monetary Limitation of liability

- 14.3.1 A Party ("Indemnifying Party") shall be liable to indemnify the other Party ("Indemnified Party") under this Article 14 for any indemnity claims made in a Contract Year only up to an amount of Rs. 0.20 Crore (Rupees Twenty Lakh Only).

14.4 Procedure for claiming indemnity

- 14.4.1 Where the Indemnified Party is entitled to indemnification from the Indemnifying Party pursuant to Articles 14.1 or 14.2 the Indemnified Party shall promptly notify the Indemnifying Party of such claim, proceeding, action or suit referred to in Articles 14.1 or 14.2 in respect of which it is entitled to be indemnified. Such notice shall be given as soon as reasonably practicable after the Indemnified Party becomes aware of such claim, proceeding, action or suit. The Indemnifying Party shall be liable to settle the indemnification claim within thirty (30) days of receipt of the above notice.

Provided however that, if:

- i. the Parties choose to contest, defend or litigate such claim, action, suit or proceedings in accordance with Article 14.4.3 below; and

- ii. the claim amount is not required to be paid/deposited to such third party pending the resolution of the Dispute,

the Indemnifying Party shall become liable to pay the claim amount to the Indemnified Party or to the third party, as the case may be, promptly following the resolution of the Dispute, if such Dispute is not settled in favour of the Indemnified Party.

- 14.4.2 The Indemnified Party may contest, defend and litigate a claim, action, suit or proceeding for which it is entitled to be indemnified under Articles 14.1 or 14.2 and the Indemnifying Party shall reimburse to the Indemnified Party all reasonable costs and expenses incurred by the Indemnified Party. However, such Indemnified Party shall not settle or compromise such claim, action, suit or proceedings without first getting the consent of the Indemnifying Party, which consent shall not be unreasonably withheld or delayed.
- 14.4.3 An Indemnifying Party may, at its own expense, assume control of the defence of any proceedings brought against the Indemnified Party if it acknowledges its obligation to indemnify such Indemnified Party, gives such Indemnified Party prompt notice of its intention to assume control of the defence, and employs an independent legal counsel at its own cost that is reasonably satisfactory to the Indemnified Party.

14.5 Limitation on Liability

- 14.5.1 Except as expressly provided in this Agreement, neither the TSP nor the Nodal Agency nor their respective officers, directors, agents, employees or Affiliates (including, officers, directors, agents or employees of such Affiliates), shall be liable or responsible to the other Party or its Affiliates including its officers, directors, agents, employees, successors, insurers or permitted assigns for incidental, indirect or consequential, punitive or exemplary damages, connected with or resulting from performance or non-performance of this Agreement, or anything done in connection herewith, including claims in the nature of lost revenues, income or profits (other than payments expressly required and properly due under this Agreement), any increased expense of, reduction in or loss of transmission capacity or equipment used therefore, irrespective of whether such claims are based upon breach of warranty, tort (including negligence, whether of the Nodal Agency, the TSP or others), strict liability, contract, breach of statutory duty, operation of law or otherwise.

14.5.2 The Nodal Agency shall have no recourse against any officer, director or shareholder of the TSP or any Affiliate of the TSP or any of its officers, directors or shareholders for such claims excluded under this Article. The TSP shall also have no recourse against any officer, director or shareholder of the Nodal Agency, or any Affiliate of the Nodal Agency or any of its officers, directors or shareholders for such claims excluded under this Article.

14.6 Duty to Mitigate

The party entitled to the benefit of an indemnity under this Article 14 shall take all reasonable measures to mitigate any loss or damage which has occurred. If the Party fails to take such measures, the other Party's liabilities shall be correspondingly reduced.

ARTICLE: 15**15 ASSIGNMENTS AND CHARGES****15.1 Assignments:**

15.1.1 This Agreement shall be binding upon, and inure to the benefit of the Parties and their respective successors and permitted assigns. This Agreement shall not be assigned by any Party, except as provided in Article 15.3.

15.2 Permitted Charges:

15.2.1 Neither Party shall create or permit to subsist any encumbrance over all or any of its rights and benefits under this Agreement.

15.2.2 However, the TSP may create any encumbrance over all or part of the receivables, or the Project Assets of the Project in favour of the Lenders or the Lenders' Representative on their behalf, as security for amounts payable under the Financing Agreements and any other amounts agreed by the Parties.

Provided that:

- i. the Lenders or the Lenders' Representative on their behalf shall have entered into the Financing Agreements and agreed in writing to the provisions of this Agreement; and
- ii. any encumbrance granted by the TSP in accordance with this Article 15.2.2 shall contain provisions pursuant to which the Lenders or the Lender's Representative on their behalf agrees unconditionally with the TSP to release from such encumbrances upon payment by the TSP to the Lenders of all amounts due under the Financing Agreements.

15.2.3 Article 15.2.1 does not apply to:

- a. liens arising by operation of law (or by an agreement evidencing the same) in the ordinary course of the TSP developing and operating the Project;
- b. pledges of goods, the related documents of title and / or other related documents, arising or created in the ordinary course of the TSP developing and operating the Project; or

- c. security arising out of retention of title provisions in relation to goods acquired in the ordinary course of the TSP developing and operating the Project.

15.3 Substitution Rights of the Lenders

- 15.3.1 The TSP would need to operate and maintain the Project under the provisions of this Agreement and cannot assign the Transmission License or transfer the Project or part thereof to any person by sale, lease, exchange or otherwise, without the prior approval of the Nodal Agency.
- 15.3.2 However, in the case of default by the TSP in debt repayments or in the case of default by the TSP as per Article 13 of this Agreement during the debt repayments, the Commission may, on an application from the Lenders, assign the Transmission License to the nominee of the Lenders subject to the fulfilment of the qualification requirements and provisions of the Central Electricity Regulatory Commission (Procedure, terms and Conditions for grant of Transmission License and other related matters) Regulations, 2006 and as amended from time to time.

ARTICLE: 16**16 GOVERNING LAW AND DISPUTE RESOLUTION****16.1 Governing Law:**

This Agreement shall be governed by and construed in accordance with the Laws of India. Any legal proceedings in respect of any matters, claims or disputes under this Agreement shall be under the jurisdiction of appropriate courts in Delhi.

16.2 Amicable Settlement:

16.2.1 Either Party is entitled to raise any claim, dispute or difference of whatever nature arising under, out of or in connection with this Agreement, including its existence or validity or termination or whether during the execution of the Project or after its completion and whether prior to or after the abandonment of the Project or termination or breach of the Agreement by giving a written notice to the other Party, which shall contain:

- (i) a description of the Dispute;
- (ii) the grounds for such Dispute; and
- (iii) all written material in support of its claim.

16.2.2 The other Party shall, within thirty (30) days of issue of notice issued under Article 16.2.1, furnish:

- (i) counter-claim and defences, if any, regarding the Dispute; and
- (ii) all written material in support of its defences and counter-claim.

16.2.3 Within thirty (30) days of issue of notice by the Party pursuant to Article 16.2.1, if the other Party does not furnish any counter claim or defense under Article 16.2.2, or thirty (30) days from the date of furnishing counter claims or defence by the other Party, both the Parties to the Dispute shall meet to settle such Dispute amicably. If the Parties fail to resolve the Dispute amicably within thirty (30) days from the later of the dates mentioned in this Article 16.2.3, the Dispute shall be referred for dispute resolution in accordance with Article 16.3.

16.3 Dispute Resolution:

All Disputes shall be adjudicated by the Commission.

16.4 Parties to Perform Obligations:

Notwithstanding the existence of any Dispute and difference referred to the Commission as provided in Article 16.3 and save as the Commission may otherwise direct by a final or interim order, the Parties hereto shall continue to perform their respective obligations/ roles (which are not in dispute) under this Agreement.

ARTICLE: 17**17 REPRESENTATION AND WARRANTIES****17.1 Representation and warranties of the Nodal Agency**

17.1.1 The Nodal Agency hereby represents and warrants to and agrees with the TSP as follows and acknowledges and confirms that the TSP is relying on such representations and warranties in connection with the transactions described in this Agreement:

- a. It has all requisite powers and authority to execute and consummate this Agreement;
- b. This Agreement is enforceable against the Nodal Agency in accordance with its terms;
- c. The consummation of the transactions contemplated by this Agreement on the part of Nodal Agency will not violate any provision of nor constitute a default under, nor give rise to a power to cancel any charter, mortgage, deed of trust or lien, lease, agreement, license, permit, evidence of indebtedness, restriction, or other contract to which the Nodal Agency is a Party or to which the Nodal Agency is bound, which violation, default or power has not been waived;

17.2 Representation and Warranties of the TSP:

17.2.1 The TSP hereby represents and warrants to and agrees with the Nodal Agency as follows and acknowledges and confirms that the Nodal Agency is relying on such representations and warranties in connection with the transactions described in this Agreement:

- a. It has all requisite powers and has been duly authorized to execute and consummate this Agreement;
- b. This Agreement is enforceable against it, in accordance with its terms;
- c. The consummation of the transactions contemplated by this Agreement on the part of the TSP will not violate any provision of nor constitute a default under, nor give rise to a power to cancel any charter, mortgage, deed of trust or lien, lease, agreement, license, permit, evidence of indebtedness, restriction, or other contract to which the TSP is a Party or to which the TSP is bound which violation, default or power has not been waived;

- d. The TSP is not insolvent and no insolvency proceedings have been instituted, nor threatened or pending by or against the TSP;
 - e. There are no actions, suits, claims, proceedings or investigations pending or, to the best of the TSP's knowledge, threatened in writing against the TSP at law, in equity, or otherwise, and whether civil or criminal in nature, before or by, any court, commission, arbitrator or governmental agency or authority, and there are no outstanding judgments, decrees or orders of any such courts, commission, arbitrator or governmental agencies or authorities, which materially adversely affect its ability to execute the Project or to comply with its obligations under this Agreement.
- 17.2.2 The TSP makes all the representations and warranties above to be valid as on the Effective Date of this Agreement.

ARTICLE: 18**18 INDEPENDENT ENGINEER****18.1 Appointment of Independent Engineer**

The Nodal Agency shall appoint an agency/ company as Independent Engineer as per framework provided in the Guidelines for Encouraging Competition in Development of Transmission Projects for selection of Independent Engineer.

18.2 Roles and functions of Independent Engineer

The role and functions of the Independent Engineer shall include the following:

- a. Progress Monitoring as required under this Agreement;
- b. Ensuring Quality as required under this Agreement;
- c. determining, as required under the Agreement, the costs of any works or services and/or their reasonableness during construction phase;
- d. determining, as required under the Agreement, the period or any extension thereof, for performing any duty or obligation during construction phase;
- e. determining, as required under the Agreement, the valuation of the Project Assets.
- f. Assisting the Parties in resolution of Disputes and
- g. Undertaking all other duties and functions in accordance with the Agreement.

18.3 Remuneration of Independent Engineer

The fee and charges of the Independent Engineer shall be paid by the Nodal Agency as per terms & conditions of appointment.

18.4 Termination of appointment

18.4.1 The Nodal Agency may, in its discretion, terminate the appointment of the Independent Engineer at any time, but only after appointment of another Independent Engineer.

18.4.2 If the TSP has reason to believe that the Independent Engineer is not discharging its duties and functions in a fair, efficient and diligent manner, it may make a written representation to the Nodal Agency and seek termination of the appointment of the Independent Engineer. Upon receipt of such representation, the Nodal Agency shall hold a tripartite meeting with the TSP and Independent Engineer for an amicable resolution, and the decision of Nodal agency is final. In the event that the appointment of the Independent Engineer is terminated hereunder, the Nodal Agency shall appoint forthwith another Independent Engineer.

18.5 Authorised signatories

The Nodal Agency shall require the Independent Engineer to designate and notify to the Nodal Agency up to 2 (two) persons employed in its firm to sign for and on behalf of the Independent Engineer, and any communication or document required to be signed by the Independent Engineer shall be valid and effective only if signed by any of the designated persons; provided that the Independent Engineer may, by notice in writing, substitute any of the designated persons by any of its employees.

ARTICLE: 19**19 MISCELLANEOUS PROVISIONS****19.1 Equity Lock-in Commitment:**

19.1.1 The aggregate equity share holding of the Selected Bidder in the issued and paid up equity share capital of Kallam Transco Limited shall not be less than Fifty-one percent (51%) up to a period of one (1) year after COD of the Project.

Provided that, in case the Lead Member or Bidding Company is holding equity through Affiliate/s, Ultimate Parent Company or Parent Company, such restriction as specified above shall apply to such entities.

Provided further, that in case the Selected Bidder is a Bidding Consortium, the Lead Member shall continue to hold equity of at least twenty-six percent (26%) upto a period of one (1) year after COD of the Project and any Member of such Bidding Consortium shall be allowed to divest its equity as long as the other remaining Members (which shall always include the Lead Member) hold the minimum equity specified above.

19.1.2 If equity is held by the Affiliates, Parent Company or Ultimate Parent Company of the Selected Bidder, then, subject to the second proviso to Article 19.1.1, such Affiliate, Parent Company or Ultimate Parent Company shall be eligible to transfer its shareholding in Kallam Transco Limited to another Affiliate or to the Parent Company / Ultimate Parent Company of the Selected Bidder. If any such shareholding entity, qualifying as an Affiliate / Parent Company / Ultimate Parent Company, is likely to cease to meet the criteria to qualify as an Affiliate / Parent Company / Ultimate Parent Company, the shares held by such entity shall be transferred to another Affiliate / Parent Company / Ultimate Parent Company of the Selected Bidder.

19.1.3 Subject to Article 19.1.1, all transfer(s) of shareholding of Kallam Transco Limited by any of the entities referred to in Article 19.1.1 and 19.1.2 above, shall be after prior written intimation to the Nodal Agency.

19.1.4 For computation of effective Equity holding, the Equity holding of the Selected Bidder or its Ultimate Parent Company in such Affiliate(s) or Parent Company and the equity holding of such Affiliate(s) or Ultimate Parent Company in Kallam Transco Limited shall be computed in accordance with the example given below:

If the Parent Company or the Ultimate Parent Company of the Selected Bidder A directly holds thirty percent (30%) of the equity in Kallam Transco Limited then holding of Selected Bidder A in Kallam Transco Limited shall be thirty percent (30%);

If Selected Bidder A holds thirty percent (30%) equity of the Affiliate and the Affiliate holds fifty percent (50%) equity in Kallam Transco Limited, then, for the purposes of ascertaining the minimum equity/equity lock-in requirements specified above, the effective holding of Bidder A in Kallam Transco Limited shall be fifteen percent (15%), (i.e., 30% x 50%)

- 19.1.5 The provisions as contained in this Article 19.1 shall override the terms of the consortium agreement submitted as part of the Bid.
- 19.1.6 The TSP shall be responsible to report to Nodal Agency, within thirty (30) days from the occurrence of any event that would result in any change in its equity holding structure from that which existed as on the date of signing of the Share Purchase Agreement. In such cases, the Nodal Agency would reserve the right to ascertain the equity holding structure and to call for all such required documents / information / clarifications as may be required.

19.2 Commitment of maintaining Qualification Requirement

- 19.2.1 The Selected Bidder will be required to continue to maintain compliance with the Qualification Requirements, as stipulated in RFP Document, till the COD of the Project. Where the Technically Evaluated Entity and/or the Financially Evaluated Entity is not the Bidding Company or a Member in a Bidding Consortium, as the case may be, the Bidding Company or Member shall continue to be an Affiliate of the Technically Evaluated Entity and/or Financially Evaluated Entity till the COD of the Project.
- 19.2.2 Failure to comply with the aforesaid provisions shall be dealt in the same manner as TSP's Event of Default as under Article 13 of this Agreement.

19.3 Language:

- 19.3.1 All agreements, correspondence and communications between the Parties relating to this Agreement and all other documentation to be prepared and supplied under the Agreement shall be written in English, and the Agreement shall be construed and interpreted in accordance with English language.
- 19.3.2 If any of the agreements, correspondence, communications or documents are prepared in any language other than English, the English

translation of such agreements, correspondence, communications or documents shall prevail in matters of interpretation.

19.4 Affirmation

The TSP and the Nodal Agency, each affirm that:

1. neither it nor its respective directors, employees, or agents has paid or undertaken to pay or shall in the future pay any unlawful commission, bribe, pay-off or kick-back; and
2. it has not in any other manner paid any sums, whether in Indian currency or foreign currency and whether in India or abroad to the other Party to procure this Agreement, and the TSP and the Nodal Agency hereby undertake not to engage in any similar acts during the Term of Agreement.

19.5 Severability

The invalidity or enforceability, for any reason, of any part of this Agreement shall not prejudice or affect the validity or enforceability of the remainder of this Agreement, unless the part held invalid or unenforceable is fundamental to this Agreement.

19.6 Counterparts

This Agreement may be executed in one or more counterparts, each of which shall be deemed an original and all of which collectively shall be deemed one and the same Agreement.

19.7 Breach of Obligations/ Roles

The Parties acknowledge that a breach of any of the obligations/ roles contained herein would result in injuries. The Parties further acknowledge that the amount of the liquidated damages or the method of calculating the liquidated damages specified in this Agreement is a genuine and reasonable pre-estimate of the damages that may be suffered by the non-defaulting Party in each case specified under this Agreement.

19.8 Restriction of Shareholders / Owners Liability

- 19.8.1 Parties expressly agree and acknowledge that none of the shareholders of the Parties hereto shall be liable to the other Parties for any of the contractual obligations of the concerned Party under this Agreement.

- 19.8.2 Further, the financial liabilities of the shareholder(s) of each Party to this Agreement shall be restricted to the extent provided in the Indian Companies Act, 1956 / Companies Act, 2013 (as the case may be).

19.9 Taxes and Duties:

- 19.9.1 The TSP shall bear and promptly pay all statutory taxes, duties, levies and cess, assessed/levied on the TSP, its Contractors or their employees that are required to be paid by the TSP as per the Law in relation to the execution of the Project and for providing Transmission Service as per the terms of this Agreement.
- 19.9.2 The Nodal Agency shall be indemnified and held harmless by the TSP against any claims that may be made against the Nodal Agency in relation to the matters set out in Article 19.9.1.
- 19.9.3 The Nodal Agency shall not be liable for any payment of, taxes, duties, levies, cess whatsoever for discharging any obligation of the TSP by the Nodal Agency on behalf of TSP or its personnel, provided the TSP has consented in writing to the Nodal Agency for such work, for which consent shall not be unreasonably withheld.

19.10 No Consequential or Indirect Losses

The liability of the TSP shall be limited to that explicitly provided in this Agreement.

Provided that, notwithstanding anything contained in this Agreement, under no event shall the Nodal Agency or the TSP claim from one another any indirect or consequential losses or damages.

19.11 Discretion:

Except where this Agreement expressly requires a Party to act fairly or reasonably, a Party may exercise any discretion given to it under this Agreement in any way it deems fit.

19.12 Confidentiality

- 19.12.1 The Parties undertake to hold in confidence this Agreement and RFP Project Documents and not to disclose the terms and conditions of the transaction contemplated hereby to third parties, except:

- (a) to their professional advisors;
- (b) to their officers, contractors, employees, agents or representatives, financiers, who need to have access to such

information for the proper performance of their activities; or

(c) disclosures required under Law,

without the prior written consent of the other Parties.

Provided that, the TSP agrees and acknowledges that the Nodal Agency, may, at any time, disclose the terms and conditions of the Agreement and the RFP Project Documents to any person, to the extent stipulated under the Law and the Competitive Bidding Guidelines.

19.13 Order of priority in application:

Save as provided in Article 2.5, in case of inconsistencies between the terms and conditions stipulated in Transmission License issued by the Commission to the TSP, agreement(s) executed between the Parties, applicable Law including rules and regulations framed thereunder, the order of priority as between them shall be the order in which they are placed below:

- terms and conditions of Transmission License;
- applicable Law, rules and regulations framed thereunder;
- this Agreement;
- Agreement(s), if any, under Sharing Regulations.

19.14 Independent Entity:

19.14.1 The TSP shall be an independent entity performing its obligations pursuant to the Agreement.

19.14.2 Subject to the provisions of the Agreement, the TSP shall be solely responsible for the manner in which its obligations under this Agreement are to be performed. All employees and representatives of the TSP or Contractors engaged by the TSP in connection with the performance of the Agreement shall be under the complete control of the TSP and shall not be deemed to be employees, representatives, Contractors of the Nodal Agency and nothing contained in the Agreement or in any agreement or contract awarded by the TSP shall be construed to create any contractual relationship between any such employees, representatives or Contractors and the Nodal Agency.

19.15 Amendments:

19.15.1 This Agreement may only be amended or supplemented by a written

agreement between the Parties.

19.16 Waiver:

- 19.16.1 No waiver by either Party of any default or breach by the other Party in the performance of any of the provisions of this Agreement shall be effective unless in writing duly executed by an authorised representative of such Party.
- 19.16.2 Neither the failure by either Party to insist on any occasion upon the performance of the terms, conditions and provisions of this Agreement nor time or other indulgence granted by one Party to the other Parties shall act as a waiver of such breach or acceptance of any variation or the relinquishment of any such right or any other right under this Agreement, which shall remain in full force and effect.

19.17 Relationship of the Parties:

This Agreement shall not be interpreted or construed to create an association, joint venture, or partnership or agency or any such other relationship between the Parties or to impose any partnership obligation or liability upon either Party and neither Party shall have any right, power or authority to enter into any agreement or undertaking for, or act on behalf of, or to act as or be an agent or representative of, or to otherwise bind, the other Party.

19.18 Entirety:

- 19.18.1 This Agreement along with its sections, schedules and appendices is intended by the Parties as the final expression of their agreement and is intended also as a complete and exclusive statement of the terms of their agreement.
- 19.18.2 Except as provided in this Agreement, all prior written or oral understandings, offers or other communications of every kind pertaining to this Agreement or the provision of Transmission Service under this Agreement to the Nodal Agency by the TSP shall stand superseded and abrogated.

19.19 Notices:

- 19.19.1 All notices or other communications which are required to be given under this Agreement shall be in writing and in the English language
- 19.19.2 If to the TSP, all notices or communications must be delivered personally or by registered post or facsimile or any other mode duly acknowledged

to the addressee below:

Address :
 Attention :
 Email :
 Fax. No. :
 Telephone No. :

19.19.3 If to the Nodal Agency, all notices or communications must be delivered personally or by registered post or facsimile or any other mode duly acknowledged to the addresses below:

(i) [Insert Name of the Nodal Agency]

Address :
 Attention :
 Email :
 Fax. No. :
 Telephone No. :

19.19.4 All notices or communications given by facsimile shall be confirmed by sending a copy of the same via post office in an envelope properly addressed to the appropriate Party for delivery by registered mail. All notices shall be deemed validly delivered upon receipt evidenced by an acknowledgement of the recipient, unless the Party delivering the notice can prove in case of delivery through the registered post that the recipient refused to acknowledge the receipt of the notice despite efforts of the postal authorities.

19.19.5 Any Party may by notice of at least fifteen (15) days to the other Party change the address and/or addresses to which such notices and communications to it are to be delivered or mailed.

19.20 Fraudulent and Corrupt Practices

19.20.1 The TSP and its respective officers, employees, agents and advisers shall observe the highest standard of ethics during the subsistence of this Agreement. Notwithstanding anything to the contrary contained in the Agreement, the Nodal Agency may terminate the Agreement without being liable in any manner whatsoever to the TSP, if it determines that the TSP has, directly or indirectly or through an agent, engaged in corrupt practice, fraudulent practice, coercive practice, undesirable practice or restrictive practice in the Bid process. In such an event, the

Nodal Agency shall forfeit the Contract Performance Guarantee of the TSP, without prejudice to any other right or remedy that may be available to the Nodal Agency hereunder or subsistence otherwise.

19.20.2 Without prejudice to the rights of the Nodal Agency under Clause 19.20.1 hereinabove and the rights and remedies which the Nodal Agency may have under this Agreement, if a TSP is found by the Nodal Agency to have directly or indirectly or through an agent, engaged or indulged in any corrupt practice, fraudulent practice, coercive practice, undesirable practice or restrictive practice during the Bid process, or after the issue of Letter of Intent (hereinafter referred to as Lol) or after the execution of the agreement(s) required under Sharing Regulations, the Nodal Agency may terminate the Agreement without being liable in any manner whatsoever to the TSP. Further, the TSP & its Affiliates shall not be eligible to participate in any tender or RFP issued by any BPC for an indefinite period from the date such TSP is found by the Nodal Agency to have directly or indirectly or through an agent, engaged or indulged in any corrupt practice, fraudulent practice, coercive practice, undesirable practice or restrictive practices, as the case may be.

19.20.3 For the purposes of this Clause 19.20, the following terms shall have the meaning hereinafter respectively assigned to them:

(a) **“corrupt practice”** means (i) the offering, giving, receiving, or soliciting, directly or indirectly, of anything of value to influence the actions of any person connected with the Bid process (for avoidance of doubt, offering of employment to or employing or engaging in any manner whatsoever, directly or indirectly, any official of the BPC who is or has been associated or dealt in any manner, directly or indirectly with the Bid process or the Lol or has dealt with matters concerning the RFP Project Documents or arising there from, before or after the execution thereof, at any time prior to the expiry of one year from the date such official resigns or retires from or otherwise ceases to be in the service of the BPC, shall be deemed to constitute influencing the actions of a person connected with the Bid Process); or (ii) engaging in any manner whatsoever, whether during the Bid Process or after the issue of the Lol or after the execution of the RFP Project Documents, as the case may be, any person in respect of any matter relating to the Project or the Lol or the RFP Project Documents, who at any time has been or is a legal, financial or technical adviser of the BPC in relation to any matter concerning the Project;

(b) **“fraudulent practice”** means a misrepresentation or omission of facts or suppression of facts or disclosure of incomplete facts, in order to influence the Bid process;

(c) “**coercive practice**” means impairing or harming, or threatening to impair or harm, directly or indirectly, any person or property to influence any person’s participation or action in the Bid process;

(d) “**undesirable practice**” means (i) establishing contact with any person connected with or employed or engaged by the BPC with the objective of canvassing, lobbying or in any manner influencing or attempting to influence the Bid process; or (ii) having a Conflict of Interest; and

(e) “**restrictive practice**” means forming a cartel or arriving at any understanding or arrangement among Bidders with the objective of restricting or manipulating a full and fair competition in the Bid process;

19.21 Compliance with Law:

Despite anything contained in this Agreement but without prejudice to Article 12, if any provision of this Agreement shall be in deviation or inconsistent with or repugnant to the provisions contained in the Electricity Act, 2003, or any rules and regulations made there under, such provision shall be deemed to be amended to the extent required to bring it into compliance with the aforesaid relevant provisions as amended from time to time.

IN WITNESS WHEREOF, THE PARTIES HAVE CAUSED THIS AGREEMENT TO BE EXECUTED BY THEIR DULY AUTHORISED REPRESENTATIVES AS OF THE DATE AND PLACE SET FORTH ABOVE.

1. For and on behalf of TSP

.....

[Signature, Name, Designation and Address]

2. For and on behalf of[Insert name of the Nodal Agency]

.....

[Signature, Name, Designation and Address]

WITNESSES:

1. For and on behalf of
: BPC

.....
[Signature]

.....
[Insert, Name, Designation and Address of the Witness]

2. For and on behalf of
: Nodal Agency

.....
[Signature]

.....
[Insert Name, Designation and Address of the Witness]

SCHEDULES

Schedule: 1**Project Description and Scope of Project****Scope of the Project:**

Sl. No.	Scope of the Transmission Scheme	Scheduled COD in months from Effective Date
1	LILO of both circuits of Parli(M) – Karjat(M)/Lonikand-II (M) 400 kV D/c line (twin moose) at Kallam PS	18 months
2	4 Nos. 400 kV line bays at Kallam PS for LILO of both circuits of Parli(M) – Karjat(M)/Lonikand-II(M) 400 kV D/c line (twin moose) at Kallam PS <ul style="list-style-type: none"> • 400 kV line bays (AIS) – 4 Nos. (for Kallam PS end) 	
3	63 MVAR, 420 kV switchable line reactor (with NGR bypassing arrangement) on each ckt at Kallam PS end of Karjat – Kallam 400 kV D/c line <ul style="list-style-type: none"> • 63 MVAR, 420 kV switchable line reactor including Switching equipment - 2 Nos. (at Kallam end)(~140km) 	

Note:

- a) TSP of Kallam PS (Kallam Transmission Ltd.) shall provide requisite space at Kallam PS for the above scope of work.
- b) The 50 MVAR fixed line reactors on each ckt at Parli (M) end of Kallam – Parli (M) 400 kV D/c line shall be converted into switchable line reactors (with NGR bypass arrangement & provision of inter-tripping scheme to trip the line reactors along with the main line breakers) by MSETCL in matching time-frame of the above scheme. MSETCL vide email dated 08.06.2023 has informed that conversion of fixed 50 MVAR line reactor at 400 kV Parli (M) (Girwali) end into switchable reactor is feasible.

Project Description

Govt. of India has set a target for establishing 500 GW capacity from non-fossil energy sources by 2030. In this direction, 2GW capacity has been identified at Kallam PS. Transmission System for evacuation of power from RE Projects in Osmanabad area (1 GW) in Maharashtra is presently under implementation by Kallam Transmission Ltd. which is expected by Oct'23. Further, augmentation of transformation capacity at Kallam PS by 2x500 MVA, 400/220 kV ICTs (3rd & 4th) along with 220kV bays for RE interconnection is also under implementation for enabling interconnection of additional 1GW at 220kV level of Kallam PS (expected by May'24).

Additional connectivity has also been granted to M/ s Torrent at 400kV level (1 no. bay) and hence there is cumulative requirement of evacuation of about 3.25GW (2GW at 220kV level and 1.25GW at 400kV level) from Kallam PS.

The subject Transmission system shall enable evacuation of power beyond 2GW at Kallam PS (upto 3.25GW), by alleviating constraints in the area, using Renewable energy sources and is expected to play a significant role in fulfilling India's vision of 500 GW of non-fossil generation capacity by 2030.

The subject scheme includes LILO of both circuits of Parli(M) – Karjat(M)/Lonikand-II (M) 400 kV D/c line (twin moose) at Kallam PS along with 63 MVAR, 420 kV switchable line reactor (with NGR bypassing arrangement) on each ckt at Kallam PS end of Karjat – Kallam 400 kV D/c line. The scheme will facilitate integration of 1.25GW power beyond 2GW at Kallam PS (i.e. upto 3.25GW).

The subject Transmission system was deliberated and approved in the 14th NCT meeting held on 09.06.2023. National Committee on Transmission vide Gazette notification dated 19.07.2023 has appointed RECPDCL as BPC for implementation of the subject transmission scheme through TBCB route.

SPECIFIC TECHNICAL REQUIREMENTS FOR TRANSMISSION LINE

The design, routing and construction of transmission lines shall be in accordance with Chapter V, Part A of CEA (Technical Standards for Construction of Electrical Plants and Electric Lines) Regulations 2022, as amended from time to time. Other CEA Regulations and MoP guidelines, as applicable, shall also be followed.

- A.1.0 Selection of tower type shall be made as per CEA Regulations, however in case lattice type towers are used, the following shall also be applicable:
- A.2.0 Steel section of grade E 250 and/or grade E 350 as per IS 2062, only are permitted for use in towers, extensions, gantry structures and stub setting templates. For towers in snowbound areas, steel sections shall conform to Grade-C of IS-2062.
- A.3.0 Towers shall be designed as per IS-802:2015, however the drag coefficient of the tower shall be as follows: -

Solidity Ratio	Drag Coefficient
Upto 0.05	3.6
0.1	3.4
0.2	2.9
0.3	2.5
0.4	2.2
0.5 and above	2.0

- A.4.0 Transmission Service Provider (TSP) shall adopt any additional loading/design criteria for ensuring reliability of the line, if so desired and /or deemed necessary.
- A.5.0 Transmission line shall be designed considering wind zones as specified in wind map given in National Building Code 2016, Vol.1. The developer shall also make his own assessment of local wind conditions and frequent occurrences of high intensity winds (HIW) due to thunderstorms, dust-storms, downburst etc. along the line route and wherever required, higher wind zone than that given in wind map shall be considered for tower design for ensuring reliability of line. Further, for transmission line sections passing within a distance of 50 km from the boundary of two wind zones, higher of the two wind zones shall be considered for design of towers located in such sections.

- A.6.0 Selection of reliability level for design of tower shall be as per CEA Regulation (Technical Standards for Construction of Electrical Plants and Electric Lines) Regulations 2022, as amended from time to time.
- A.7.0 A) For power line crossing of 400 kV or above voltage level, large angle & dead end towers (i.e. D/DD/QD) shall be used on either side of power line crossing.
- B) For power line crossing of 132 kV and 220 kV voltage level, angle towers (B/C/D/DB/DC/DD/QB/QC/QD) shall be used on either side of power line crossing depending upon the merit of the prevailing site condition and line deviation requirement.
- C) For power line crossing of 66 kV and below voltage level, suspension/tension towers shall be provided on either side of power line crossing depending upon the merit of the prevailing site condition and line deviation requirement.
- D) For crossing of railway tracks, national highways and state highways, the rules/ regulations of appropriate authorities shall be followed.
- A.8.0 The relevant conductor configuration for 400kV shall be as follows: -

Transmission line	ACSR Conductor specified	Equivalent AAAC conductor based on 53% conductivity of Al Alloy	Equivalent minimum size of AL59 conductor based on 59% conductivity of AL Alloy*	Sub-conductor Spacing
400kV D/C (Twin Moose) transmission lines	Moose: Stranding 54/3.53mm-Al + 7/3.53 mm-Steel, 31.77 mm diameter 528.5 sq. mm, Aluminium area, Maximum DC Resistance at 20°C (Ω/km): 0.05552	Stranding details 61/3.55mm 31.95mm diameter; 604 sq. mm Aluminium alloy area Maximum DC Resistance at 20°C (Ω/km): 0.05506	Stranding details: 61/3.31mm 29.79 mm diameter; 525 sq. mm Aluminium alloy area Maximum DC Resistance at 20°C (Ω/km): 0.0566	450 mm

	Minimum UTS: 161.20 kN	Minimum UTS: 159.80 kN	Minimum UTS: 124.70 kN	
--	---------------------------	---------------------------	---------------------------	--

Note:

- *To Select any size above the minimum, the sizes mentioned in the Indian standard IS-398(part-6) shall be followed.
- The transmission lines shall have to be designed for a maximum operating conductor temperature of 85 deg C.

A.9.0 The required phase to phase spacing and horizontal spacing for 400kV line shall be governed by the tower design as well as minimum live metal clearances for 400kV voltage level under different insulator swing angles. However, the phase to phase spacing for 400kV line shall not be less than 8 m.

A.10.0 Electrical clearances including minimum live metal clearance, ground clearance and minimum mid span separation between earth wire and conductor as given below shall be considered:

Minimum live metal clearances for 400 kV line:(i) Under stationary conditions

From tower body: 3.05 m

(ii) Under swing conditions

Wind pressure Condition	Minimum electrical clearance
a) Swing angle (22°)	3.05 m
b) Swing angle (44°)	1.86 m

(iii) Minimum ground clearance: 8.84 m

(iv) Minimum mid span separation between earth-wire and conductor: 9.0 m

A.11.0 Shielding angle shall not exceed 20 deg for 400kV D/C Line transmission line.

A.12.0 The Fault current for design of line shall be 63kA for 1 sec for 400kV.

A.13.0 In case of 400kV & above voltage class lines, at least one out of two earth wires shall be OPGW and second earth wire, if not OPGW, shall be either of galvanized standard steel (GSS) or Aluminium Alloy Conductor Steel Reinforced (AACSR) conductor type. or any other suitable conductor type depending upon span length and other technical consideration.

A.14.0 Each tower shall be earthed such that tower footing impedance does not exceed 10 ohms. Pipe type or Counterpoise type earthing shall be provided in

accordance with relevant IS. Additional earthing shall be provided on every 7 to 8 kms distance for direct earthing of both shield wires. If site condition demands, multiple earthing or use of earthing enhancement compound shall be used.

- A.15.0 Pile type foundation shall be used for towers located in river or creek bed or on bank of river having scourable strata or in areas where river flow or change in river course is anticipated, based on detailed soil investigation and previous years' maximum flood discharge of the river, maximum velocity of water, highest flood level, scour depth & anticipated change in course of river based on river morphology data of at least past 20 years to ensure availability and reliability of the transmission line.
- A.16.0 Transmission line route shall be finalized, in consultation with appropriate authorities so as to avoid the habitant zones of endangered species and other protected species. Bird diverters, wherever required, shall be provided on the line.
- A.17.0 Wherever, transmission lines are passing through cyclone prone areas i.e. areas upto 60 km from coast following shall also be applicable:
- a) Terrain category-I, with terrain roughness factor (K2) of 1.08 shall be considered for tower design for exposed open terrain with few or no obstruction which also includes open sea coasts, open stretch of water, desert and flat treeless plains
 - b) Importance factor for cyclonic region (K4) of 1.3 shall be considered for tower design.
 - c) The number of consecutive spans between the section points/ angle point shall not exceed 10 spans or 3km instead of conventional practice of 15 spans or 5km, in order to reduce the failure of such towers in coastal areas due to cascading effect. The section shall be terminated with tension tower/ angle tower and angle of deviation should be based on the site requirement.
- A.18.0 Wherever, transmission lines are passing through cyclone prone areas (i.e. areas upto 60 km from coast)/ creek regions/ aggressive soil areas following shall also be applicable:
- a) The fabricated tower parts and stubs shall have a minimum overall zinc coating of 900 g/m² of surface area except for plates and sections below 5 mm which shall have a minimum overall zinc coating of 610 g/m² of surface area. The average zinc coating for all sections and plates 5mm and above shall be maintained as 127 microns and that for plates and sections below 5mm shall be maintained as 87 microns.
 - b) Ready mix concrete of M30 Grade shall be used to avoid use of locally

available saline water. However, design mix concrete of M30 Grade conforming to IS 456 with potable water can be used at locations where transportation of ready-mix concrete is not feasible. Minimum cement content in any case shall not be less than 330 kg/m³.

- c) The surface of the reinforced steel shall be treated with epoxy-based coating to enhance corrosion performance of foundation. Use of epoxy coated reinforcement in foundation shall be as per IS 13620. In addition, two (2) coats of bituminous painting of minimum 1.6 kg/m² per coat shall be applied on all exposed faces of foundation (i.e. pedestal & base slab).
- d) Double coat 20 mm thick cement plaster shall be provided on all exposed concrete surface as well up to 300 mm below ground level to give protection to concrete surface from environmental and saline effect.
- e) Before coping of chimney top portion, three coats of anti-corrosive paint of minimum 30-35 microns dry film thickness each shall be applied on the stub in the 50mm coping portion as well as up to 350 mm above CL portion.

A.19.0 The raised chimney foundation is to be provided in areas prone to flooding/water stagnation like paddy field /agricultural field & undulated areas to avoid direct contact of water with steel part of tower. The top of the chimney of foundation should be at least above HFL (High Flood Level) or the historical water stagnation/ logging level (based on locally available data) or above High Tide Level or 500 mm above Natural Ground level (whichever is higher).

A.20.0 Routing of transmission line through protected areas of India shall be avoided to the extent possible. In case, it is not possible to avoid protected areas, the towers of the transmission line upto 400 kV level which are installed in protected areas shall be designed for Multi-circuit (4 circuits) configuration of same voltage level considering reliability level of at least two (2). The top two circuits of these multi-circuit towers shall be used for stringing of the transmission line under present scope and the bottom two circuits shall be made available for stringing of any future transmission line of any transmission service providers/ State transmission utilities/Central transmission utilities passing through the same protected area. Further, the configuration and coordinates of such transmission towers shall be submitted to CEA, CTU & BPC by the TSP.

A.21.0 The TSP shall abide by the Guidelines of CEA w.r.t. shifting of transmission lines for NHAI projects and other projects.

A.22.0 Safety precautions in regards to gas/oil pipe lines in vicinity of Transmission lines shall be taken in coordination with gas/ petroleum authorities.

SPECIFIC TECHNICAL REQUIREMENTS FOR SUBSTATION

The proposed extension of Kallam substation shall be conventional Air Insulated Switchgear (AIS) type generally conforming to the requirements of CEA (Technical Standards for Construction of Electrical Plants and Electric Lines) Regulations 2022, as amended from time to time. Other CEA Regulations and MoP guidelines, as applicable, shall also be followed.

B.1.0 Salient features of Substation Equipment and Facilities

The design and specification of substation equipment are to be governed by the following factors:

B.1.1 Insulation Coordination

The system design parameters for substations/switchyards shall be as given below:

Sl. No	Description of parameters	400kV Kallam (AIS)
		S/s 400 kV System
1.	System operating voltage	400kV
2.	Maximum voltage of the system (rms)	420kV
3.	Rated frequency	50Hz
4.	No. of phase	3
5.	Rated Insulation levels	
i)	Lighting Impulse withstand voltage for (1.2/50 micro sec.) - for Equipment other than Transformer and Reactors - for Insulator String	1425kVp 1550kVp
ii)	Switching impulse withstand voltage (250/2500 micro sec.) dry and wet	1050kVp
iii)	One minute power frequency dry withstand voltage (rms)	630 kV
6.	Corona extinction voltage	320 kV
7.	Max. radio interference voltage for frequency between 0.5 MHz and 2MHz	1000 micro- volts at 266kV rms
8.	Minimum creepage distance for insulator string/ longrod insulators/outdoor bushings	13020 mm (31mm/kV)
9.	Minimum creepage distance for switchyard equipment	10500mm (25mm/kV)
10.	Max. fault current	63kA
11.	Duration of fault	1 sec

B.1.2 Switching Scheme

The switching schemes, as mentioned below, shall be adopted at various voltage levels of substation/switchyard:

Substation	400kV side
400kV Kallam Extn. (AIS)	One & half breaker

Notes: -

- i) *For one and half breaker switching scheme, any double circuit line consisting of two numbers of feeders and originating from the same transmission or generating switchyard shall not be terminated in one diameter.*
- ii) *A diameter in one and half breaker scheme is a set of 3 circuit breakers with associated isolators, earth switches, current transformers etc. for controlling of 2 numbers of feeders.*
- iii) *Connection arrangement of Switchable Line reactors shall be such that it can be used as Line reactor as well as Bus reactor with suitable NGR bypass arrangement.*
- iv) *TSP shall plan distribution of line and transformer feeders to bus bar in such a way that all power can be evacuated successfully without crossing thermal limit at any point of bus-bar.*
- v) *400kV line bays shall be constructed such that provision is kept for future switchable line reactors.*
- vi) *Kallam S/S:
400kV: Bays identified for LILO of both circuits of Parli(M) – Karjat(M)/Lonikand-II (M) 400 kV D/c line are shown in attached SLD & GA drawing of Kallam S/S. As per the GA drawing out of 4 circuits, 3 circuits shall be terminated in new diameters for which main & tie bays are to be constructed under the present scope. Remaining 1 circuit shall be terminated in main bay no. 419 under present scope for which tie bay is excluded as the same is being constructed in separate scheme.*

Further, Line gantries shall be constructed for termination of all the four (4) circuits considering the provision of switchable line reactor as shown in GA drawing.

B.2.0 Substation Equipment and facilities (Voltage level as applicable):

The switchgear shall be designed and specified to withstand operating conditions and duty requirements. All equipment shall be designed considering the following capacity.

Sl. No	Description of bay	400kV Kallam (AIS) Extn.
		400kV
1.	Bus Bar	As per existing

Sl. No	Description of bay	400kV Kallam (AIS) Extn.
2.	Line bay	3150A

B.2.1 Shunt Reactors

B.2.1.1 420kV, 3-Phase, Shunt Reactor

63MVAR, 420 KV, 3-Phase Reactor shall conform to CEA's "Standard Specifications and Technical Parameters for Transformers and Reactors (66 kV and above)" as amended up to date available on CEA website.

The Ohmic value of NGR for Line Reactors shall be as follows:

Sl. No.	Line Name	NGR value
1.	63 MVAR, 420 kV switchable line reactor on each ckt of Karjat – Kallam 400kV D/c line at Kallam PS end.	400 Ohms

B.2.2 400kV AIS Substation equipment (as applicable)

B.2.2.1 Circuit Breakers (AIS)

The circuit breakers and accessories shall conform to IEC: 62271-100, IEC: 62271-1 and shall be of SF6 Type. The circuit breakers shall be of class C2-M2 (as per IEC) with regard to restrike probability during capacitive current breaking and mechanical endurance. Each breaker would have two sets of trip circuits which would be connected to separate DC supplies for greater reliability. The rated break time shall not exceed 40ms for 400kV circuit breakers. The Circuit breakers controlling 400kV lines of more than 200km length shall be provided either with pre-insertion closing resistor of 400 ohms with 8ms insertion time or with Controlled Switching Device. 400kV Circuit breakers shall be provided with single phase and three phase auto reclosing. The short line fault capacity shall be same as the rated capacity and this is proposed to be achieved without use of opening resistors. Controlled switching device shall be provided in 400kV Circuit breakers of switchable line reactor bay and in Main & Tie bay circuit breakers of line with non-switchable line reactors and Bus reactors.

B.2.2.2 Isolators (AIS)

The isolators shall comply to IEC 62271-102 in general. 400kV isolator design shall be double break type. All isolators and earth switches shall be motor operated. Earth switches shall be provided at various locations to facilitate maintenance. Isolator rated for 400kV shall be of extended mechanical endurance class - M2 and suitable for bus transfer current switching duty as per IEC-62271-

102. Main blades and earth blades shall be interlocked and interlock shall be fail safe type. 400kV earth switches for line isolator shall be suitable for induced current switching duty as defined for Class-B.

B.2.2.3 Current Transformers (AIS)

Current Transformers shall comply with IEC 61869 in general. All ratios shall be obtained by secondary taps only. Generally, Current Transformers (CT) for 400kV shall have six cores (four for protection and two for metering). The burden and knee point voltage shall be in accordance with the requirements of the system including possible feeds for telemetry. Accuracy class for protection core shall be PX and for metering core it shall be 0.2S. The rated burden of cores shall be closer to the maximum burden requirement of metering & protection system (not more than 20VA for metering core) for better sensitivity and accuracy. The instrument security factor shall be less than 5 for CTs upto 400kV voltage class.

B.2.4.1 Capacitive Voltage Transformers (AIS)

Capacitive Voltage transformers shall comply with IEC 61869 in general. These shall have three secondaries out of which two shall be used for protection and one for metering. Accuracy class for protection cores shall be 3P and for metering core it shall be 0.2. The Capacitive voltage transformers on lines shall be suitable for Carrier Coupling. The Capacitance of CVT for 400kV shall be of 4400/8800 pF depending on PLCC requirements. The rated burden of cores shall be closer to the maximum burden requirement of metering & protection system (not more than 50VA for metering core) for better sensitivity and accuracy.

B.2.4.2 Surge Arresters (AIS)

336 kV Station High (SH) duty gapless type Surge arresters with thermal energy (W_{th}) of minimum 12 kJ/kV conforming to IEC 60099-4 in general shall be provided for 400kV system. Other characteristics of Surge arrester shall be chosen in accordance with system requirements. Surge arresters shall be provided near line entrances, Transformers & Reactor so as to achieve proper insulation coordination. Surge Arresters shall be provided with porcelain/ polymer housing fitted with pressure relief devices. A leakage current monitor with surge counter shall be provided with each surge arrester.

B.2.5 Protection Relaying & Control System

The protective relaying system proposed to be provided for transmission lines, auto-transformers, reactors and bus bars to minimize the damage to the equipment in the events of faults and abnormal conditions, is dealt in this section. All main protective relays shall be numerical type with IEC 61850 communication interface and should have interoperability during integration of numerical relays to

communicate over IEC61850 protocol with RTU/SAS/IEDs of different OEMs. All numerical relays shall have built in disturbance recording feature.

The protection circuits and relays of transformer and reactor shall be electrically and physically segregated into two groups each being independent and capable of providing uninterrupted protection even in the event of one of the protection groups failing, to obtain redundancy, and to take protection systems out for maintenance while the equipment remains in service.

a) Transmission Lines Protection

400kV lines shall have Main-I numerical three zone distance protection scheme with carrier aided inter-tripping feature. 400kV lines shall also have Main-II numerical distance protection scheme like Main-I but from different make that of Main-I. The Main-I and Main-II protection relays of same make may be provided only if they are of different hardware & manufacturing platform or different principle of operation.

However, Line Current Differential relay (with back up distance protection feature) as Main-I and Main-II shall be considered at both ends for short lines (line length below 30KM) having Fibre Optic communication link. Differential relay at remote end shall be provided by the TSP. Associated power & control cabling and integration with SAS at remote end shall be provided by respective bay owner.

In case of loop in loop out of transmission lines, the existing protection scheme shall be studied and suitable up-gradation (if required) shall be carried out.

Further, all 400kV lines shall be provided with single and three phase auto-reclosing facility to allow reclosing of circuit breakers in case of transient faults. These lines shall also be provided with distance to fault locators to identify the location of fault on transmission lines.

All 400kV lines shall also be provided with two stages over voltage protection. Over voltage protection & distance to fault locator may be provided as in-built feature of Main-I & Main-II protection relays. Auto reclose as built-in function of Bay Control Unit (BCU) is also acceptable.

The Main-I and Main-II protection relays shall be fed from separate DC sources and shall be mounted in separate panels.

For 400kV transmission lines, directional IDMT earth fault relay should be provided as standalone unit or in-built feature of Main-I and Main -II feature.

b) 400kV Reactor Protection

Reactor shall be provided with the following protections:

- i) Numerical Differential protection.

- ii) Numerical Restricted earth fault protection
- iii) Numerical Back-up impedance protection

Besides these, reactors shall also be provided with Buchholz relay, MOG with low oil level alarm, protection against oil and winding temperatures & pressure relief device, etc.

c) Bus bar Protection

The high speed low impedance type bus bar differential protection, which is essential to minimize the damage and maintain system stability at the time of bus bar faults, shall be provided for 400kV buses. Duplicated bus bar protection is envisaged for 400kV bus-bar protection. Bus bar protection scheme shall be such that it operates selectively for each bus and incorporate necessary features required for ensuring security. The scheme shall have complete bus bar protection for present as well as envisaged future bays i.e., input / output modules for future envisaged bays shall also be provided.

In case, the bus section is provided, then each side of bus section shall have separate set of bus bar protection schemes.

For existing substations, the existing bus bar protection shall be augmented as per requirement.

d) Local Breaker Back up Protection

This shall be provided for each 400kV circuit breakers and will be connected to de-energize the affected stuck breaker from both sides.

Notes:

1. *LBB & REF relays shall be provided separately from transformer differential relay.*
2. *LBB relay may also be provided as built-in protection function of distributed bus bar protection scheme; however in such case separate LBB relay shall be provided for tie bays (in case of One and Half breaker scheme).*
3. *Over fluxing & overload protection can be provided as built-in feature of differential relay.*
4. *In 400kV switchyard, if spare bay of half diameter is identified as future, Tie CB relay panel shall be with Auto-reclosure feature.*

B.2.6 Substation Automation System

- a)** For all the new substations, state of art Substation Automation System (SAS) conforming to IEC-61850 shall be provided. The distributed architecture shall be used for Substation Automation system, where the controls shall be provided through Bay control units. The Bay control unit is to be provided bay wise for

voltage level 400kV and above. All bay control units as well as protection units are normally connected through an Optical fibre high speed network. The control and monitoring of circuit breaker, dis-connector, re-setting of relays etc. can be done from Human Machine Interface (HMI) from the Control Room.

The functions of control, annunciation, disturbance recording, event logging and measurement of electrical parameters shall be integrated in Substation Automation System.

At new substations, the Substation Automation System (SAS) shall be suitable for operation and monitoring of the complete substation including proposed future bays/elements.

In existing substations with Substation automation system (SAS), augmentation of existing SAS shall be done for bays under present scope.

In existing Substations where Substation automation is not provided, control functions shall be done through control panels.

Necessary gateway & modems (as required) shall be provided to send data to RLDC/SLDC as per their requirement. Any augmentation work at RLDC/SLDC is excluded from TSP's scope. However, all the configuration work at substation end required to send data to RLDC/SLDC shall be in the scope of TSP.

b) Time synchronization equipment

Time synchronization equipment complete in all respect including antenna, cable, processing equipment required to receive time signal through GPS or from National Physical Laboratory (NPL) through INSAT shall be provided at new substations. This equipment shall be used to synchronize SAS & IEDs etc.

B.3.0 Substation Support facilities

Certain facilities required for operation & maintenance of substations as described below shall be provided at new substation. In existing substation, these facilities have already been provided and would be extended/ augmented as per requirement.

B.3.1 AC & DC power supplies

For catering the requirements of three phase & single phase AC supply and DC supply for various substation equipment (for present and future scope), existing facilities shall be augmented as required.

B.3.2 Fire Fighting System

Fire-fighting system for substation including transformer & reactor shall conform to CEA (Measures Relating to Safety & Electric Supply) Regulations, 2023, as amended time to time.

Further, adequate water hydrants and portable fire extinguishers shall be provided in the substations. The main header of firefighting system shall be suitable for extension to bays covered under the future scope; necessary piping interface in this regard shall be provided.

At existing substations, the fire-fighting systems as available shall be extended to meet the additional requirements.

B.3.3 Oil evacuating, filtering, testing & filling apparatus

To monitor the quality of oil for satisfactory performance of transformers, shunt reactors and for periodical maintenance necessary oil evacuating, filtering, testing and filling apparatus would be provided at new substations. Oil storage tanks of adequate capacities for storage of transformer oil would be provided.

B.3.4 Illumination

Normal & emergency AC & DC illumination shall be provided adequately in the control room & other buildings of the substation. The switchyard shall also be provided with adequate illumination.

Lighting of the entire control room building, fire-fighting pump house, other building (if any) and switchyard shall be done by LED based low power consumption luminaries.

B.3.5 Control Room

For new substation, substation control room shall be provided to house substation work stations for station level control (SAS) alongwith its peripheral and recording equipment, AC & DC distribution boards, DC batteries & associated battery chargers, Fire Protection panels, Telecommunication panels & other panels as per requirements. Air conditioning shall be provided in the building as functional requirements. Main cable trenches from the control room shall have adequate space provision for laying of cables from control room for all the future bays also.

At existing substations, the adequacy of size of control room shall be ascertained and the same shall be augmented as per requirement.

B.3.7 Control Concept

All the EHV circuit breakers in substation/switching stations shall be controlled and synchronized from the switchyard control room/remote control center. All the isolators shall have control from remote/local whereas the earth switches shall have local control only.

B.3.8 Visual monitoring system (VMS) for watch and ward of substation premises:

Visual monitoring system for effective watch and ward of substation premises shall cover all the transformers and reactors, all other major AIS Equipment (such as CB, isolators, CT, CVT, SA etc. as applicable), GIS bays, panel room, all the gates of switchyard and all entry and exit points of control room building and accordingly the location of cameras shall be decided. The camera shall be high definition color CCD camera with night vision feature. The VMS data partly/completely shall be recorded (minimum for 15 days) at least @25fps (or better) and stored on network video recorder. The system shall use video signals from various cameras installed at different locations, process them for viewing on workstations/monitors in the control room and simultaneously record all the cameras.

Mouse/keyboard controllers shall be used for pan, tilt, zoom and other functions of the desired camera. The Visual Monitoring System shall have provision of WAN connectivity for remote monitoring.

All camera recordings shall have Camera ID & location/area of recording as well as date/time stamp. The equipment should generally conform to Electromagnetic compatibility requirement for outdoor equipment in EHV substation.

At existing substations, the visual monitoring system if available shall be augmented as per existing or better specification as required.

B.4 General Facilities

- a) Line Gantry/Towers are envisaged for bays under present scope only. However, for adjacent future line bay, tower shall be designed for extension (considering Quad conductors for 400kV future lines) wherever applicable.
- b) Bay extension works at existing substation shall be executed by TSP in accordance with the requirement/provisions mentioned above. However, interface points shall be considered keeping in view the existing design/arrangement at the substation.
- c) TSP has to arrange for construction power and water on its own.
- d) All outdoor steel structures including anchor/foundation bolts shall be fully galvanized. The weight of the zinc coating shall be at least 610 g/m². However, for coastal/creek regions it shall be at least 900 g/m².
- e) In 400kV switchyard, if spare bay of half diameter is identified as future, all the equipment for Tie & Future Bay shall be designed considering the current rating of line bay i.e., 3150A.
- f) All electrical equipment shall be installed above Highest Flood Level and where such equipment is not possible to be installed above Highest Flood Level, it shall be ensured that there is no seepage or leakage or logging of water.

B.5 EXTENSION OF EXISTING SUBSTATION

The following drawings/details of existing substation is attached with the RFP documents for further engineering by the bidder.

SI. No.	Drawing Title	Drawing No./Details	Rev. No.
A.	400kV Kallam S/S		
1.0	Single Line Diagram	IGT-KTL-ELEC-SLD001	-
2.0	General Arrangement	IGT-KTL-ELEC-LAY001	-
3.0	Earthmat Layout	Drawings for previous scheme are yet to be finalized by the developer	
4.0	Visual Monitoring System		
5.0	Bus Bar Protection		
6.0	Substation Automation System (SAS)	GE Make	-

Bidder is also advised to visit the substation sites and acquaint themselves with the topography, infrastructure such as requirement of roads, cable trench, drainage etc. and also the design philosophy.

SPECIFIC TECHNICAL REQUIREMENTS FOR COMMUNICATION

The communication requirement shall be in accordance with CEA (Technical Standards for Communication System in Power System Operations) Regulations, 2020, CEA (Technical Standards for Construction of Electrical Plants and Electric Lines) Regulations, 2022, CERC (Communication System for inter-State transmission of electricity) Regulations, 2017, and CEA (Cyber Security in Power Sector) Guidelines, 2021, all above documents as amended from time to time.

The complete ISTS communication system commissioned by TSP under the RFP shall be the asset of ISTS and shall be available for usage of ISTS requirements as suggested by CTU from time to time.

The protections for transmission line and the line compensating equipment shall have hundred percent back up communication channels i.e. two channels for tele- protection in addition to one channel for speech plus data for each direction.

In order to meet the requirement for grid management and operation of substations, Transmission Service Provider (TSP) shall provide the following:

C.1.0 LILO of both circuits of Parli(M) – Karjat(M)/Lonikand-II (M) 400 kV D/c line (twin moose) at Kallam PS.

On LILO of both circuits of 400 kV D/c Parli (M) – Karjat(M)/ Lonikhand-II (M) 400 kV D/c line (twin moose) at Kallam S/s, TSP shall supply, install & commission OPGW and earthwire as per Tower Configurations:

- (i) For Multi Circuit Tower Configuration: Two (2) no. OPGW cable containing 24 Fibres (24F) to be installed & commissioned by the TSP on both the Earthwire peaks
- (ii) For Double Circuit Tower configuration (for both Loop In and Loop Out portion): One (1) no. OPGW cable containing 24 Fibres (24 F) on one earthwire peak & conventional earthwire on other E/W peak for both Loop In and Loop Out Lines.

The TSP shall install OPGW cables from gantry of Kallam S/s up to the LILO tower with all associated hardware including Vibration Dampers, mid-way & gantry Joint Boxes (called OPGW Hardware hereafter) and finally terminate in Joint Boxes at Kallam S/s. The transmission line length is **15 kms (approx.)**. After LILO, if fiber length for links Parli (M) to Kallam PS and Kallam PS to Lonikhand (M) is above 225 kms then repeater shall be envisaged, otherwise line can be managed as a repeater less link.

TSP shall finalize the location of repeater station depending upon the actual site conditions. Further TSP shall comply to the requirements mentioned as per **Appendix-F.1**

Maintenance of OPGW Cable, OPGW Hardware & repeater equipment & items associated with repeater shelter shall be responsibility of TSP.

C.2.0 4 Nos. 400 kV line bays at Kallam PS for LILO of both circuits of Parli(M) – Karjat(M)/ Lonikand-II(M) 400 kV D/c line (twin moose) at Kallam PS

- (i) TSP shall supply, install & commission 1 no. FODP (72F or higher) alongwith panel and required Approach Cable (24F) with all associated hardware fittings from gantry tower to Bay Kiosk and from the Bay Kiosk to Control room.
- (ii) TSP shall supply, install & commission One STM-16 (FOTE) equipment alongwith panel/s supporting minimum three (3) directions with MSP (Multiplex Section Protection – 1+1) with necessary interfaces to meet the voice and data communication requirement among **Kallam S/s, Parli (M) S/s and Karjat(M)/ Lonikand-II (M) S/s**. The suitable DC Power Supply and backup to be provided for communication equipment.
- (iii) FOTE/FODP panel shall be installed in the new Bay Kiosk. The FOTE under present scope shall be integrated by TSP with the existing FOTE at control room of **Kallam S/s** which shall be communicating with respective control center. TSP to provide necessary FODP sub rack / Splice trays/ Patch cords etc. and optical interfaces/equipment in the existing FOTE/FODP panels in control room for integration with the existing FOTE for onwards data transmission.

In case spare optical direction is not available in the existing FOTE at the control room, the TSP shall coordinate with station owner to reconfigure the directions in existing FOTE at control room. Alternatively, The TSP may integrate the FOTE under the present scope with existing FOTE in the nearby Kiosk connected to the control room FOTE (if available with spare direction). For this purpose, TSP shall provide necessary FODP sub rack / Splice trays/ Patch cords etc. and suitable optical interfaces/ equipment in the existing FOTE/FODP panels in another Kiosk (SPR).
- (iv) FOTE & FODP can be accommodated in same panel to optimize space.
- (v) The new communication equipment under the present scope shall be compatible for integration with existing regional level centralized NMS. The local configuration of the new communication equipment shall be the responsibility of TSP. The configuration work in the existing centralized NMS for integration of new Communication equipment shall be done by Regional ULDC Team, however all the necessary support in this regard shall be ensured by TSP.
- (vi) The maintenance of all the communication equipment and software thereof including FOTE, PMU, FODP, approach cable, DCPS alongwith Battery Bank shall be the responsibility of TSP.

C.3.0 Specific Requirement for Phasor Measurement Units (PMUs)

TSP shall supply, install & commission required no. of Phasor Measurement Units (PMUs) PMUs at all the locations under the scope of TSP under this RFP as per CEA (Technical Standards for Construction of Electrical Plants and Electric Lines) Regulations, 2022 (alongwith all amendments if any), and all the applicable Regulations, Standards, Guidelines issued time to time. These PMUs shall be provided with GPS clock and LAN switch and shall connect with LAN switch of control room of respective substations/ generating stations with Fibre Optic cable. These PMUs shall be connected with the FOTE at Substation/ generating stations for onwards data transmission to the PDC (Phasor Data Concentrator) located at respective RLDC. Configuration work in existing PDC at RLDC for new PMU integration shall be done by respective RLDC, however all the necessary support in this regard shall be ensured by TSP. The maintenance of all the PMUs and associated equipment shall be the responsibility of TSP.

Note: Existing Station owner/s to provide necessary support to integrate different equipment & applications of new extended bays with the existing substation e.g. Communication (through FOTE), Voice etc. for smooth operation and monitoring of new added grid elements.

Appendix-F.1

Repeater Requirements

- If the repeater location is finalized in the Control Room of a nearby substation, TSP shall provide 1 no. OPGW (48F) on a single Earthwire peak with OPGW Hardware & mid-way Joint Boxes etc. of the line crossing the main line and 1 no. Approach Cable (48F) with all associated hardware fittings, to establish connectivity between crossing point of main transmission line up to the repeater equipment in substation control room.
TSP shall co-ordinate for Space & DC power supply sharing for repeater equipment.
TSP shall provide FODP, FOTE (with STM-16 capacity) with suitable interfaces require for link budget of respective link.

OR

- If the repeater location is finalized in the nearby substation premises, the TSP shall identify the Space for repeater shelter in consultation with station owner. Further TSP shall provide 1 no. OPGW (48F) on a single Earthwire peak with OPGW Hardware & mid-way Joint Boxes etc. of the line crossing the main line and 1 no. Approach Cable (48F) / UGFO (48F) with all associated hardware fittings, to establish connectivity between crossing point of main transmission line up to the substation where the repeater shelter is to be housed.
TSP shall provide repeater shelter along with FODP, FOTE (with STM-16 capacity) with suitable interfaces require for link budget of respective link, reliable power supply provisioning for AC and DC supply, battery bank, Air Conditioner and other associated systems.

OR

- If the repeater location is finalized on land near the transmission tower. TSP shall make the provisions for Land at nearby tower for repeater shelter. Further TSP shall provide 1 no. Approach Cable (48F) / UGFO (48F) with all associated hardware fittings to establish connectivity up to the location of repeater shelter.
TSP shall provide repeater shelter along with FODP, FOTE (with STM-16 capacity) with suitable interfaces require for link budget of respective link, reliable power supply provisioning for AC and DC supply, battery bank, Air Conditioner and other associated systems

Maintenance of OPGW Cable and **OPGW Hardware**, repeater equipment & items associated with repeater shelter shall be responsibility of TSP.

Proposed Communication for Transmission Scheme for Western Region Network Expansion scheme in Kallam area of Maharashtra

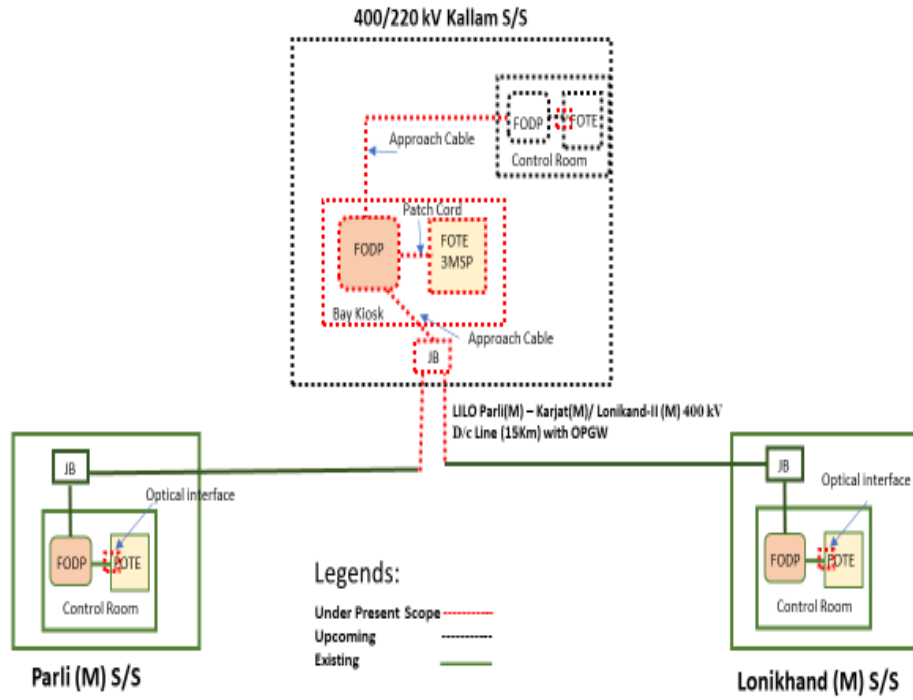

C.4.0 PLCC & PABX

Power line carrier communication (PLCC) equipment complete for speech, tele-protection commands and data channels shall be provided on each transmission line. The PLCC equipment shall in brief include the following: -

- Coupling device, line traps, carrier terminals, protection couplers, HF cables, PABX (if applicable) and maintenance and testing instruments.
- Coupling devices shall be suitable for phase-to-phase coupling for 400kV Transmission lines. The pass band of coupling devices shall have sufficient margin for adding communication channel in future if required. Necessary protection devices for safety of personnel and low voltage part against power frequency voltages and transient over voltage shall also be provided.
- The line traps shall be broad band tuned suitable for blocking the complete range of carrier frequencies. Line Trap shall have necessary protective devices such as lightning arresters for the protection of tuning device. Decoupling network consisting of line traps and coupling capacitors may also be required at certain substation in case of extreme frequency congestion.
- The carrier terminals shall be of single side-band (SSB) amplitude modulation (AM) type and shall have 4 kHz band width. PLCC Carrier terminals and Protection couplers shall be considered for both ends of the line.
- TSP shall provide/ undertake necessary addition/ modification/ shifting/ re-commissioning etc. of PLCC equipment due to LILO of transmission lines (wherever applicable).
 - LILO of both circuits of Parli(M) –Karjat(M)/Lonikand-II(M) 400kV D/c line at Kallam PS:

Sl. No	Line name	PLCC configuration
1	Parli(M) – Kallam 400kV D/c line.	1 set Analog PLCC + 1 set Digital Protection Coupler for each circuit at each end.
2	Karjat(M)- Kallam & Lonikand-II(M)-Kallam line	1 set Analog PLCC + 1 set Digital Protection Coupler for each circuit at each end.
Existing PLCC panels of Parli(M) –Karjat(M)/Lonikand-II(M) 400kV D/c line may also be utilized.		

- All other associated equipment like CVT, Line Trap, cabling, coupling device and HF cable shall also be provided by the TSP.

- **Frequently Asked Queries:****1.0 Transmission Line:**

- 1.1 Please clarify that whether shutdowns for crossing of existing transmission lines of POWERGRID/STUs/ Power Evacuation Lines from Generation Plants/ Any other Transmission Licensee will be given to TSP on chargeable basis or free of cost.

Reply: Shutdowns for crossing of existing transmission lines of POWERGRID/ STUs/ Power Evacuation Lines from Generation Plants/ Any other Transmission Licensee will be given to TSP by the concerned owner of the lines as per their own terms & conditions. As far as shutdown of ISTS lines are concerned the same can be availed by approaching respective Regional Power Committee.

- 1.2 We understand that the suggested swing angle criteria are applicable for Suspension Insulator in Suspension Tower. Further, you are requested to provide similar swing angle and clearance criteria for Pilot Insulator with Jumper & Jumper.

Reply: It is clarified that the swing angle criteria (as mentioned in RFP) for transmission lines is applicable for Suspension Insulator in Suspension Tower. Further, as per Clause 3.0 of Specific Technical Requirements for transmission lines, Transmission service Provider (TSP) shall adopt any additional loading/design criteria for ensuring reliability of the line, if so desired and /or deemed necessary.

- 1.3 We request you to kindly allow that use of diamond configuration at Power line crossings and the existing owner of the lines may be directed to allow the same for the successful bidders.

Reply: Power line crossing including Diamond configuration is responsibility of the TSP. TSP shall formally submit the profile of the crossing section to the owner of the existing line suggesting proposed crossing alternatives. The crossing will have to be carried out as per approval of owner of the existing line.

- 1.4 It is requested you to kindly provide present status of Forest Clearances if any transmission line corridor area falling in wildlife forest / reserve forest/ mangroves.

Reply: Based on the preliminary route survey, the process of initiation of forest clearance for the forest stretches, if any, enroute the proposed line alignment will be initiated by way of writing letters to the concerned authority (ies). However, it may be noted that it will be the responsibility of TSP for obtaining forest clearance for the forest stretches as provided in the survey report and also for any forest area encountered during detailed survey.

2.0 Substation

2.1 We understand that space for storage of O&M spare shall be provided by existing owner within the station boundary without any cost. Kindly confirm.

Reply: Space for storage of O&M spares shall be arranged by TSP on its own.

2.2 We presume that the O&M for the end Termination bays will be in the scope of the TSP and TSP shall not be liable for any payment towards O&M to the existing owner of the substation. Kindly confirm.

Reply: Operation and maintenance of the bays is solely responsibility of the TSP. TSP shall follow CEA's "Operation and Maintenance (O&M) guidelines and Standard Format for Memorandum of Understanding between New TSP and Existing TSP" issued by CEA vide its letter No. I/28514/2023 dated 22.06.2023.. Copy of the guideline is available on CEA website at following link:

https://cea.nic.in/wp-content/uploads/pse_td/2023/06/om_guidelines.pdf

2.3 With reference to subject scheme of existing sub-station, we assumed following scope of work:

- (a) We assumed internal road is available and need not to consider in the present scope of work.
- (b) Drainage is available and need not to consider in the present scope of work.
- (c) Cable trench extension in adjacent to Main cable trench only under present scope of work.
- (d) Levelled area being provided by developer for bay extension.

Reply: Regarding requirement of internal road, drainage, cable trench, leveling of the bay extension area, bidder is advised to visit site and acquaint themselves with the provisions/facilities available at substation.

2.4 Kindly provide the soil investigation report of soil parameters of existing substation.

Reply: Bidder is advised to visit the substation site and ascertain the requisite parameters.

2.5 Kindly confirm, energy accounting of aux. power consumption. Whether it will be on chargeable basis or part of transmission loss.

Reply: It will be on chargeable basis.

2.6 We understand that VMS requirement is for unmanned stations only. For Manned stations VMS is not compulsory.

Reply: VMS shall be provided in line with requirements of RfP document.

2.7 It is understood that Construction water and power shall be provided free of cost to TSP by respective substation owner for construction of new bays.

Reply: Arrangement of construction power & water is in the scope of TSP.

2.8 It is understood that existing fire hydrant system shall be extended by the TSP for bay extension.

Reply: Existing fire hydrant system shall be extended from existing system (if required)

2.9 Please clarify that Status of land acquisition for Substations. Whether the lands have been acquired by BPC and will be transferred to TSP.

Reply: The acquisition of land for substation is in the scope of TSP.

2.10 We understood that no any dedicated metering CT & CVT required for Line/feeders. Further, we understood that requisite Energy meters for various 765kV, 400kV & 220kV Feeders shall be provided & installed by CTU free of cost to TSP.

Reply: Dedicated metering CT and CVT are not required for line/feeders. Metering core of existing CT/CVT can be used provided accuracy class is matching with metering requirement. Requisite Special Energy Meters shall be provided and installed by CTU at the cost of TSP in C&P panel subject to space availability, else, in separate metering panel (to be provided by TSP at its cost).

2.11 It is understood that TSP to follow the RFP for Technical Requirement. Only interface drawings like CRP & SCADA shall be coordinated with existing S/S owner.

Reply: All necessary coordination shall be done with exiting s/s owner w.r.t interface along with augmentation required as per RfP.

2.12 We understand that there are only two communication channels, Chanel-1 for protection-1+ Speech via. PLCC, Chanel-2 for Protection-2 + data via. FOTE. Hence, we do not envisage any separate channel for speech + data as the same can be achieved with FOTE system. Therefore, we understand that TSP is allowed to implement best possible solutions accordingly. Kindly confirm

Reply: PLCC equipment for all the transmission lines covered under the scheme (consisting of one set of analog PLCC channel along with circuit protection coupler and one set of Digital protection coupler for both ends) shall be provided by TSP. Further, OPGW based terminal equipment shall be utilized for Speech+ Data.

2.13 We understand that one set of analog circuit protection coupler shall be for PLCC and another set for Digital protection coupler for FOTE. Kindly confirm.

Reply: PLCC equipment for all the transmission lines covered under the scheme (consisting of one set of analog PLCC channel along with circuit protection coupler and one set of Digital protection coupler for both ends) shall be provided by TSP. Further, OPGW based terminal equipment shall be utilized for Speech+Data.

3.0 Communication

3.1 What are the usage of OPGW, FOTE, PMU etc. under communication requirement of RFP?

Reply: User shall be responsible for providing compatible equipment along with appropriate interface for uninterrupted communication with the concerned control center and shall be responsible for successful integration with the communication system provided by CTU.

Communication systems e.g. OPGW, FOTE, PMU etc. are required for grid operation through RLDC/SLDC, speech communication, tele-protection and tele-metering.

3.2 Is space for installation of communication panels are provided to TSP in existing Substations incase new bays are in the scope of TSP?

Reply: The space replated issues are deliberated in the RFP itself. TSP to carry out survey of the existing substation for physical space requirement. In case space is not available in the existing substation then TSP shall accommodate the same in the respective bay SPR (Switchyard Panel Room)/Bay Kiosk/ Relay panel room in case of GIS s/s. Further, TSP to connect and integrate the proposed FOTE with the existing FOTE in the Relay Panel Room.

In Case 132kV Substation TSP shall accommodate the said panels either by extension of existing Relay Panel Room or other arrangements.

3.3 How is the OPGW laying done in case of LILO lines?

Reply: In case LILO lines are on same towers (e.g. both Line in and Line Out portion are on same towers, generally done LILO of S/C lines). Then 2x24F OPGW shall be required to install by TSP on both earthwire peak on 400kV & 765kV lines where two E/W peaks are available. On 220 & 133kV lines where only one E/W peak is available TSP to install one no. 48F OPGW.

Incase LILO lines are on different towers (e.g. both Line In and Line Out portion are on different towers, generally done LILO of D/C lines). Then 1x24F OPGW shall be required to install by TSP on one earthwire peak, on both Line In and Line Out portions of 400kV & 765kV lines. On 220 & 133kV lines where only one E/W peak is available TSP to install one no. 24F OPGW in place of conventional earthwire.

3.4 How is the OPGW laying done in case Multi circuit Towers?

Reply: In case two different lines are using common multi circuit portion for some distance (originating from different stations, may be terminating on same or on different stations). Two no. 24F OPGW to be installed on both E/W peaks for common M/C portion of 765kV & 400kV lines.

In case 220/132kV lines using multi circuit portion where single E/W peak is available one no. 48F may be installed for common multi circuit portion.

Schedule: 2**Scheduled COD**

[Note: As referred to in the definition of “Element”, “Scheduled COD”, and in Articles 3.1.3 (c), 4.1 (b) and 4.3 (a) of this Agreement]

SI. No.	Name of the Transmission Element	Scheduled COD	Percentage of Quoted Transmission Charges recoverable on Scheduled COD of the Element of the Project	Element(s) which are pre-required for declaring the commercial operation date (COD) of the respective Element
1.	LILO of both circuits of Parli(M) – Karjat(M)/Lonikand-II (M) 400 kV D/c line (twin moose) at Kallam PS	18 months from date of SPV acquisition	100%	All Elements are required to be commissioned simultaneously as their utilization is dependent on commissioning of each other.
2.	4 Nos. 400 kV line bays at Kallam PS for LILO of both circuits of Parli(M) – Karjat(M)/Lonikand-II(M) 400 kV D/c line (twin moose) at Kallam PS			
3.	63 MVAR, 420 kV switchable line reactor (with NGR bypassing arrangement) on each ckt at Kallam PS end of Karjat – Kallam 400 kV D/c line (~140km.)			

The payment of Transmission Charges for any Element, irrespective of its successful commissioning on or before its Scheduled COD, shall only be considered after successful commissioning of the Element(s), which are pre-required for declaring the commercial operation date of such Element as mentioned in the above table.

Scheduled COD for the Project is: 18 months from the date of SPV Transfer.

[Note: List of Element(s) along with the critical Element(s) to be provided by CEA]

Schedule: 3**Safety Rules and Procedures**

[Note: As referred to in Articles 5.6 of this Agreement]

1: Site Regulations and Safety:

The TSP shall establish Site regulations within sixty (60) days from fulfilment of conditions subsequent, as per Prudent Utility Practices setting out the rules to be observed till expiry of the Agreement at the Site and shall comply therewith.

Such Site regulations shall include, but shall not be limited to, rules in respect of security, safety of the Project, gate control, sanitation, medical care, and fire prevention, public health, environment protection, security of public life, etc.

Copies of such Site regulations shall be provided to the Nodal Agency and the CEA for the purpose of monitoring of the Project.

2: Emergency Work:

In cases of any emergency, the TSP shall carry out all necessary remedial work as may be necessary.

If the work done or caused to be done by any entity, other than the TSP, the TSP shall, reimburse the actual costs incurred, to the other Party carrying out such remedial works.

3: Site Clearance:

In the course of execution of the Agreement, the TSP shall keep the Site reasonably free from all unnecessary obstruction, storage, remove any surplus materials, clear away any wreckage, rubbish and temporary works from the Site, and remove any equipment no longer required for execution of the Agreement. After completion of all Elements of the Project, the TSP shall clear away and remove all wreckage, rubbish and debris of any kind from the Site, and shall leave the Site clean and safe.

4: Watching and Lighting:

The TSP shall provide and maintain at its own expense all lighting, fencing, and watching when and where necessary for the proper construction, operation, maintenance / repair of any of the Elements of the Project, or for the safety of the owners and occupiers of adjacent property and for the safety of the public, during such maintenance / repair.

Schedule: 4**Computation of Transmission Charges****1.1 General**

The Monthly Transmission Charges to be paid to the TSP for providing Transmission Service for any Contract Year during the term of the Agreement shall be computed in accordance with this Schedule and paid as per Sharing Regulations.

Illustration regarding payment of Transmission Charges under various scenarios (considering definitions of Contract Year, Expiry Date & Monthly Transmission Charges above) is as below: -

Illustration-1: In case the Project Elements achieve COD as per Schedule

Quoted Transmission Charges: **Rs. 140 Million**

Completion Schedule:

Element No.	Completion Schedule in Months	Scheduled CoD of the Element	Actual CoD of the Element	% Charges recoverable on Scheduled CoD of the Element
Element 1	28	1-Feb-2018	1-Feb-2018	25%
Element 2	38	1-Dec-2018	1-Dec-2018	75%

Tariff Payable as follows:

Transmission Charges for Element 1			Transmission Charges for Element 2		
1-Feb-18 to 31-Mar-18	$140 \times 25\% \times ((28+31)/365)$	5.65		--	0.00
1-Apr-18 to 30-Nov-18	$140 \times 25\% \times (244/365)$	23.39		--	0.00
1-Dec-18 to 31-Mar-19	$140 \times 100\% \times (121/365)$				46.41
2	$140 \times 100\% \times 1$				140
3	$140 \times 100\% \times 1$				140
4	$140 \times 100\% \times 1$				140
5	$140 \times 100\% \times 1$				140
.....					
.....					
36 (1-Apr to 30-Nov)	$140 \times 100\% \times (244/365)$				93.59

Illustration-2: In case of extension of Scheduled COD as per Article 4.4.1 & 4.4.2 of this AgreementQuoted Transmission Charges: **Rs. 140 Million**

Completion Schedule:

Element No.	Completion Schedule in Months	Scheduled CoD of the Element	Actual CoD of the Element	% Charges recoverable on Scheduled CoD of the Element
Element 1	20	1-Feb-2018	1-Jul-2018	25%
Element 2	28	1-Oct-2018	1-Dec-2018	75%

Tariff Payable as follows:

Transmission Charges for Element 1			Transmission Charges for Element 2		
1-Feb-18 to 31-Mar-18	--	0.00		--	0.00
1-Apr-18 to 30-Jun-18	--	0.00		--	0.00
1-Jul-18 to 30-Nov-18	140 X 25% X (153/365)	14.67		--	0.00
1-Dec-18 to 31-Mar-19	140 X 100% X (121/365)				46.41
2	140 X 100% X 1				140
3	140 X 100% X 1				140
4	140 X 100% X 1				140
5	140 X 100% X 1				140
.....					
.....					
36 (1-Apr to 30-Nov)	140 X 100% X (244/365)				93.59

Illustration-3: In case of delay in achieving COD of Project & all individual Elements (COD of the Project achieved in Contract Year 1)Quoted Transmission Charges: **Rs. 140 Million**

Completion Schedule:

Element No.	Completion Schedule in Months	Scheduled CoD of the Element	Actual CoD of the Element	% Charges recoverable on Scheduled CoD of the Element
Element 1	20	1-Feb-2018	1-Dec-2018	25%
Element 2	28	1-Oct-2018	1-Dec-2018	75%

Tariff Payable as follows:

Transmission Charges for Element 1			Transmission Charges for Element 2		
1-Feb-18 to 31-Mar-18	--	0.00		--	0.00
1-Apr-18 to 30-Sept-18	--	0.00		--	0.00
1-Oct-18 to 30-Nov-18	--	0.00	1-Oct-18 to 30-Nov-18	--	0.00
1-Dec-18 to 31-Mar-19	140 X 100% X (121/365)				46.41
2	140 X 100% X 1				140
3	140 X 100% X 1				140
4	140 X 100% X 1				140
5	140 X 100% X 1				140
.....					
.....					
36 (1-Apr to 30-Nov)	140 X 100% X (244/365)				93.59

Illustration-4: In case of delay in achieving COD of Project & all individual Elements (COD of the Project achieved in Contract Year other than Contract Year 1)

Quoted Transmission Charges: **Rs. 140 Million**

Completion Schedule:

Element No.	Completion Schedule in Months	Scheduled CoD of the Element	Actual CoD of the Element	% Charges recoverable on Scheduled CoD of the Element
Element 1	38	1-Oct-2019	1-May-2020	25%
Element 2	38	1-Oct-2019	1-May-2020	75%

Tariff Payment to be paid as:

Transmission Charges for Element 1			Transmission Charges for Element 2		
1-Oct-19 to 31-Mar-20	--	0.00	1-Oct-19 to 31-Mar-20	--	0.00
1-Apr-20 to 30-Apr-20	-	0.00	1-Apr-20 to 30-Apr-20	-	0.00
1-May-20 to 31-Mar-21	140 X 100% X (335/365)				128.49
2	140 X 100% X 1				140
3	140 X 100% X 1				140
4	140 X 100% X 1				140
5	140 X 100% X 1				140
.....					
.....					
36 (1-Apr to 30-Apr)	140 X 100% X (30/ 365)				11.51

516

Transmission Service Agreement

Illustration5: In case of delay in achieving COD of Element but Project COD achieved on time

Quoted Transmission Charges: **Rs. 140 Million**

Completion Schedule:

Element No.	Completion Schedule in Months	Scheduled CoD of the Element	Actual CoD of the Element	% Charges recoverable on Scheduled CoD of the Element
Element 1	20	1-Feb-2018	1-Jul-2018	25%
Element 2	30	1-Dec-2018	1-Dec-2018	75%

Tariff Payable as follows:

Transmission Charges for Element 1			Transmission Charges for Element 2		
1-Feb-18 to 31-Mar-18	--	0.00		--	0.00
1-Apr-18 to 30-Jun-18	--	0.00		--	0.00
1-Jul-18 to 30-Nov-18	140 X 25% X (153/365)	14.67		--	0.00
1-Dec-18 to 31-Mar-19	140 X 100% X (121/365)				46.41
2	140 X 100% X 1				140
3	140 X 100% X 1				140
4	140 X 100% X 1				140
5	140 X 100% X 1				140
.....					
.....					
36 (1-Apr to 30-Nov)	140 X 100% X (244/365)				93.59

Illustration-6: In case of early commissioning of ProjectQuoted Transmission Charges: **Rs. 140 Million**

Completion Schedule:

Element No.	Completion Schedule in Months	Scheduled CoD of the Element	Actual CoD of the Element	% Charges recoverable on Scheduled CoD of the Element
Element 1	38	1-Oct-2019	1-Jul-2019	25%
Element 2	38	1-Oct-2019	1-Jul-2019	75%

Tariff Payment to be paid as:

Transmission Charges for Element 1		Transmission Charges for Element 2	
1-July-19 to 31-Mar-20	140 X 100% X (274/365)		105.09
2	140 X 100% X 1		140
3	140 X 100% X 1		140
4	140 X 100% X 1		140
5	140 X 100% X 1		140
.....			
.....			
36 (1-Apr to 30-Jun)	140 X 100% X (91/365)		34.91

Illustration-7: In case of early commissioning of an elementQuoted Transmission Charges: **Rs. 140 Million**

Completion Schedule:

Element No.	Completion Schedule in Months	Scheduled CoD of the Element	Actual CoD of the Element	% Charges recoverable on Scheduled CoD of the Element
Element 1	38	1-Oct-2019	1-Apr-2019	25%
Element 2	38	1-Jul-2019	1-Jul-2019	75%

Tariff Payment to be paid as:

Transmission Charges for Element 1			Transmission Charges for Element 2		
1-Apr-2019 to 30-Jun-19	140 X 25% X (91/365)	8.72	1-Apr-2019 to 30-Jun-19	--	0.00
1-July-19 to 31-Mar-20	140 X 100% X (274/ 365)				105.09
2	140 X 100% X 1				140
3	140 X 100% X 1				140
4	140 X 100% X 1				140
5	140 X 100% X 1				140
.....					
.....					
36 (1-Apr-30-Jun)	140 X 100% X (91/365)				34.91

The Transmission Charges shall be payable on monthly basis as computed above.

1.2 Computation of Monthly Transmission Charges

The Monthly Transmission Charges for any month m in a Contract Year n shall be calculated as below:

For AC System:

- a. If Actual Transmission System Availability for the month m of contract year n is greater than or equal to 98% and less than or equal to 98.5%;

$$\text{Monthly Transmission Charges MTC}(m) = T_{mn} * 1$$

- a. If Actual Transmission System Availability for the month m of contract year n exceeds 98.5% and less than or equal to 99.75%;

Transmission Service Agreement

Monthly Transmission Charges $MTC(m) = T_{mn} * (AA/ 98.5\%)$

- c. If Actual Transmission System Availability for the month m of contract year n is greater than 99.75%;

Monthly Transmission Charges $MTC(m) = T_{mn} * (99.75\% / 98.5\%)$

- d. If Actual Transmission System Availability for the month m of contract year n is less than 98% and greater than or equal to 95.00%;

Monthly Transmission Charges $MTC(m) = T_{mn} * (AA/ 98\%)$

- e. If Actual Transmission System Availability for the month m of contract year falls below 95%;

Monthly Transmission Charges $MTC(m) = T_{mn} * (AA/ 98\%) - 0.02 * (T_{mn} * (AA/ 95\%))$

For DC System:

- a. If Actual Transmission System Availability for the month m of contract year n is greater than or equal to 95% and less than or equal to 96%;

Monthly Transmission Charges $MTC(m) = T_{mn} * 1$

- b. If Actual Transmission System Availability for the month m of contract year n exceeds 96% and less than or equal to 99.75%;

Monthly Transmission Charges $MTC(m) = T_{mn} * (AA/ 96\%)$

- c. If Actual Transmission System Availability for the month m of contract year n is greater than 99.75%;

Monthly Transmission Charges $MTC(m) = T_{mn} * (99.75\% / 96\%)$

- d. If Actual Transmission System Availability for the month m of contract year n is less than 95% and greater than or equal to 92.00%;

Monthly Transmission Charges $MTC(m) = T_{mn} * (AA/ 95\%)$

- e. If Actual Transmission System Availability for the month m of contract year falls below 92%;

Monthly Transmission Charges $MTC(m) = T_{mn} * (AA/ 95\%) - 0.02 * (T_{mn} * (AA/ 92\%))$

where:

- AA is the actual Availability, as certified by RPC, as per procedure provided in Schedule 6.
- m is the month in Contract Year 'n'

- T_{mn} = Transmission Charges for the month 'm' in Contract Year 'n' =
(=Transmission Charge/ no. of days in the Year n)* no. of days in month
m

Provided, no Transmission Charges shall be paid during the period for which the RLDC has not allowed the operation of the Element/Project due to the failure of the TSP to operate it as per the provisions of the Grid Code.

1.3 RLDC Fee & Charges

The payment of RLDC fee & charges, in accordance with relevant regulations of CERC, shall be the responsibility of the TSP.

Schedule: 5**Quoted Transmission Charges**

[Quoted Transmission Charges from Annexure - 21 of the RFP of the Selected Bidder to be inserted here]

[To be incorporated from the Bid of the Selected Bidder submitted during the e-reverse auction after its selection]

Quoted Transmission Charges: Rs. Million

Proportionate Transmission Charges payable for each Element of the Project:

Sl. No.	Name of the Transmission Element	Percentage of Quoted Transmission Charges recoverable on Scheduled COD of the Element of the Project	Element(s) which are pre-required for declaring the commercial operation date (COD) of the respective Element
1.	LILO of both circuits of Parli(M) – Karjat(M)/Lonikand-II (M) 400 kV D/c line (twin moose) at Kallam PS	100%	All Elements are required to be commissioned simultaneously as their utilization is dependent on commissioning of each other.
2.	4 Nos. 400 kV line bays at Kallam PS for LILO of both circuits of Parli(M) – Karjat(M)/Lonikand-II(M) 400 kV D/c line (twin moose) at Kallam PS		
3.	63 MVAR, 420 kV switchable line reactor (with NGR bypassing arrangement) on each ckt at Kallam PS end of Karjat – Kallam 400 kV D/c line (~140km.)		

Schedule: 6**Appendix II of the Central Electricity Regulatory Commission (Terms and Conditions of Tariff) Regulations 2019****Procedure for Calculation of Transmission System Availability Factor for a Month**

1. Transmission system availability factor for nth calendar month ("TAFPn") shall be calculated by the respective transmission licensee, got verified by the concerned Regional Load Dispatch Centre (RLDC) and certified by the Member-Secretary, Regional Power Committee of the region concerned, separately for each AC and HVDC transmission system and grouped according to sharing of transmission charges. In case of AC system, transmission System Availability shall be calculated separately for each Regional Transmission System and inter-regional transmission system. In case of HVDC system, transmission System Availability shall be calculated on consolidate basis for all inter-state HVDC system.
2. Transmission system availability factor for nth calendar month ("TAFPn") shall be calculated by consider following:
 - i) **AC transmission lines:** Each circuit of AC transmission line shall be considered as one element;
 - ii) **Inter-Connecting Transformers (ICTs):** Each ICT bank (three single phase transformer together) shall form one element;
 - iii) **Static VAR Compensator (SVC):** SVC along with SVC transformer shall form one element;
 - iv) **Bus Reactors or Switchable line reactors:** Each Bus Reactors or Switchable line reactors shall be considered as one element;
 - v) **HVDC Bi-pole links:** Each pole of HVDC link along with associated equipment at both ends shall be considered as one element;
 - vi) **HVDC back-to-back station:** Each block of HVDC back-to-back station shall be considered as one element. If associated AC line (necessary for transfer of inter- regional power through HVDC back-to-back station) is not available, the HVDC back-to-back station block shall also be considered as unavailable;
 - vii) **Static Synchronous Compensation ("STATCOM"):** Each STATCOM shall be considered as separate element.
3. The Availability of AC and HVDC portion of Transmission system shall be calculated by considering each category of transmission elements as under:

TAFMn (in %) for AC system:

$$= \frac{o \times AV_o + (p \times AV_p) + (q \times AV_q) + (r \times AV_r) + (u \times AV_u)}{(o + p + q + r + u)} \times 100$$

Where,

- o = Total number of AC lines.
- AV_o = Availability of o number of AC lines.
- p = Total number of bus reactors/switchable line reactors
- AV_p = Availability of p number of bus reactors/switchable line reactors
- q = Total number of ICTs.
- AV_q = Availability of q number of ICTs.
- r = Total number of SVCs.
- AV_r = Availability of r number of SVCs
- u = Total number of STATCOM.
- AV_u = Availability of u number of STATCOMs

TAFMn (in %) for HVDC System:

$$= \frac{\sum_{x=1}^s C_{xpb}(\text{act}) \times AV_{xpb} + \sum_{y=1}^t C_{ybtb}(\text{act}) \times AV_{ybtb}}{\sum_{x=1}^s C_{xpb} + \sum_{y=1}^t C_{ybtb}} \times 100$$

Where

- C_{xpb}(act) = Total actual operated capacity of xth HVDC pole
- C_{xpb} = Total rated capacity of xth HVDC pole

AVx _{bp}	=	Availability of x th HVDC pole
Cy _{btb(act)}	=	Total actual operated capacity of y th HVDC back-to-back station block
Cy _{btb}	=	Total rated capacity of y th HVDC back-to-back station block
AVy _{btb}	=	Availability of y th HVDC back-to-back station block
s	=	Total no of HVDC poles
t	=	Total no of HVDC Back to Back blocks

4. The availability for each category of transmission elements shall be calculated based on the weightage factor, total hours under consideration and non-available hours for each element of that category. The formulae for calculation of Availability of each category of the transmission elements are as per **Appendix-III**. The weightage factor for each category of transmission elements shall be considered as under:
 - (a) For each circuit of AC line – Number of sub-conductors in the line multiplied by ckt-km;
 - (b) For each HVDC pole- The rated MW capacity x ckt-km;
 - (c) For each ICT bank – The rated MVA capacity;
 - (d) For SVC- The rated MVAR capacity (inductive and capacitive);
 - (e) For Bus Reactor/switchable line reactors – The rated MVAR capacity;
 - (f) For HVDC back-to-back station connecting two Regional grids- Rated MW capacity of each block; and
 - (g) For STATCOM – Total rated MVAR Capacity.
5. The transmission elements under outage due to following reasons shall be deemed to be available:
 - i. Shut down availed for maintenance of another transmission scheme or construction of new element or renovation/upgradation/additional capitalization in existing system approved by the Commission. If the other transmission scheme belongs to the transmission licensee, the Member Secretary, RPC may restrict the deemed availability period to that considered reasonable by him for the work involved. In case of dispute regarding deemed availability, the matter may be referred to Chairperson, CEA within 30 days.
 - ii. Switching off of a transmission line to restrict over voltage and manual tripping of switched reactors as per the directions of concerned RLDC.
6. For the following contingencies, outage period of transmission elements, as certified by the Member Secretary, RPC, shall be excluded from the total time of the element under period of consideration for the following contingencies:

- i) Outage of elements due to acts of God and force majeure events beyond the control of the transmission licensee. However, whether the same outage is due to force majeure (not design failure) will be verified by the Member Secretary, RPC. A reasonable restoration time for the element shall be considered by Member Secretary, RPC and any additional time taken by the transmission licensee for restoration of the element beyond the reasonable time shall be treated as outage time attributable to the transmission licensee. Member Secretary, RPC may consult the transmission licensee or any expert for estimation of reasonable restoration time. Circuits restored through ERS (Emergency Restoration System) shall be considered as available;
- ii) Outage caused by grid incident/disturbance not attributable to the transmission licensee, e.g. faults in substation or bays owned by other agency causing outage of the transmission licensee's elements, and tripping of lines, ICTs, HVDC, etc. due to grid disturbance. However, if the element is not restored on receipt of direction from RLDC while normalizing the system following grid incident/disturbance within reasonable time, the element will be considered not available for the period of outage after issuance of RLDC's direction for restoration;

Provided that in case of any disagreement with the transmission licensee regarding reason for outage, same may be referred to Chairperson, CEA within 30 days. The above need to be resolved within two months:

Provided further that where there is a difficulty or delay beyond sixty days, from the incidence in finalizing the recommendation, the Member Secretary of concerned RPC shall allow the outage hours on provisional basis till the final view.

7. Time frame for certification of transmission system availability: (1) Following schedule shall be followed for certification of availability by Member Secretary of concerned RPC:
- Submission of outage data by Transmission Licensees to RLDC/ constituents
 - By 5th of the following month;
 - Review of the outage data by RLDC / constituents and forward the same to respective RPC – by 20th of the month;
 - Issue of availability certificate by respective RPC – by 3rd of the next month.

Appendix-III

FORMULAE FOR CALCULATION OF AVAILABILITY OF EACH CATEGORY OF TRANSMISSION ELEMENTS

For AC transmission system

$$AV_o(\text{Availability of } o \text{ no. of AC lines}) = \frac{\sum_{i=1}^o W_i(T_i - TN_{Ai})/T_i}{\sum_{i=1}^o W_i}$$

$$AV_q(\text{Availability of } q \text{ no. of ICTs}) = \frac{\sum_{k=1}^q W_k(T_k - TN_{Ak})/T_k}{\sum_{k=1}^q W_k}$$

$$AV_r(\text{Availability of } r \text{ no. of SVCs}) = \frac{\sum_{i=1}^r W_i(T_i - TN_{Ai})/T_i}{\sum_{i=1}^r W_i}$$

$$AV_p(\text{Availability of } p \text{ no. of Switched Bus reactors}) = \frac{\sum_{m=1}^p W_m(T_m - TN_{Am})/T_m}{\sum_{m=1}^p W_m}$$

$$AV_u(\text{Availability of } u \text{ no. of STATCOMs}) = \frac{\sum_{n=1}^u W_n(T_n - TN_{An})/T_n}{\sum_{n=1}^u W_n}$$

$$AV_{x_{bp}}(\text{Availability of an individual HVDC pole}) = \frac{(T_x - TN_x)}{T_x}$$

$$AV_{y_{btb}}(\text{Availability of an individual HVDC Back-to-back Blocks}) = \frac{(T_y - TN_{Ay})}{T_y}$$

For HVDC transmission system

For the new HVDC commissioned but not completed twelve months;

For first 12 months: $[(AV_{x_{bp}} \text{ or } AV_{y_{btb}}) \times 95\% / 85\%]$, subject to ceiling of 95%.

Where,

- o = Total number of AC lines;
- AV_o = Availability of o number of AC lines;
- p = Total number of bus reactors/switchable line reactors;
- AV_p = Availability of p number of bus reactors/switchable line reactors;
- q = Total number of ICTs;
- AV_q = Availability of q number of ICTs;
- r = Total number of SVCs;
- AV_r = Availability of r number of SVCs;
- U = Total number of STATCOM;

AV_u	=	Availability of u number of STATCOMs;
W_i	=	Weightage factor for i th transmission line;
W_k	=	Weightage factor for k th ICT;
W_l	=	Weightage factors for inductive & capacitive operation of l th SVC;
W_m	=	Weightage factor for m th bus reactor;
W_n	=	Weightage factor for n th STATCOM.
$T_i, , T_k, T_l, , -$ T_m, T_n, T_x, T_y		The total hours of i th AC line, k th ICT, l th SVC, m th Switched Bus Reactor & n th STATCOM, x th HVDC pole, y th HVDC back-to-back blocks during the period under consideration (excluding time period for outages not attributable to transmission licensee for reasons given in Para 5 of the procedure)
$T_{NAi}, T_{NAk} -$ $T_{NAl}, T_{NAM},$ $T_{NAn}, T_{NAx}, T_{NAy}$		The non-availability hours (excluding the time period for outages not attributable to transmission licensee taken as deemed availability as per Para 5 of the procedure) for i th AC line, k th ICT, l th SVC, m th Switched Bus Reactor, n th STATCOM, x th HVDC pole and y th HVDC back-to-back block.

Schedule: 7

Entire Bid (both financial bid and technical bid) of the Selected Bidder to be attached here

Schedule: 8**Contract Performance Guarantee**

(To be on non-judicial stamp paper of appropriate value as per Stamp Act relevant to place of execution. Foreign entities submitting Bids are required to follow the applicable law in their country.)

In consideration of the[Insert name of the SPV or Selected Bidder on behalf of the TSP, or Lead Member in case of the Consortium, with address] agreeing to undertake the obligations under the Transmission Service Agreement datedand the other RFP Project Documents and the Nodal Agency and the[Insert the name of the BPC], agreeing to execute the *RFP Project Documents* with the Selected Bidder, regarding setting up the Project, the [Insert name and address of the bank issuing the guarantee and address of the head office] (hereinafter referred to as "Guarantor Bank") hereby agrees unequivocally, irrevocably and unconditionally to pay to (being the Nodal Agency) at[Insert the Place from the address of the Nodal Agency indicated in the TSA] forthwith on demand in writing from the Nodal Agency or any Officer authorized by it in this behalf, any amount up to and not exceeding Rupees Crores (Rs.) only [Insert the amount of the bank guarantee] on behalf of M/s. [Insert name of the Selected Bidder or SPV].

This guarantee shall be valid and binding on the Guarantor Bank up to and includingand shall not be terminable by notice or any change in the constitution of the Bank or the term of the Transmission Service Agreement or by any other reasons whatsoever and our liability hereunder shall not be impaired or discharged by any extension of time or variations or alternations made, given, or agreed with or without our knowledge or consent, by or between parties to the respective agreement.

Our liability under this Guarantee is restricted to Rs. Crores (Rs.) only. Our Guarantee shall remain in force until [Insert the date of validity of the Guarantee as per Article 3.1.2 of this Agreement]. The Nodal Agency, shall be entitled to invoke this Guarantee up to three hundred sixty five (365) days of the last date of the validity of this Guarantee.

The Guarantor Bank hereby expressly agrees that it shall not require any proof in addition to the written demand from (in its roles as the Nodal Agency), made in any format, raised at the above mentioned address of the Guarantor Bank, in order to make the said payment to Nodal Agency.

The Guarantor Bank shall make payment hereunder on first demand without restriction or conditions and notwithstanding any objection by [Insert name of the Selected Bidder], [Insert name of the TSP] and / or any other person. The Guarantor Bank shall not require Nodal Agency to justify the invocation of this BANK GUARANTEE, nor shall the Guarantor Bank have any recourse against Nodal Agency in respect of any payment made hereunder.

THIS BANK GUARANTEE shall be interpreted in accordance with the laws of India.

The Guarantor Bank represents that this BANK GUARANTEE has been established in such form and with such content that it is fully enforceable in accordance with its terms as against the Guarantor Bank in the manner provided herein.

THIS BANK GUARANTEE shall not be affected in any manner by reason of merger, amalgamation, restructuring, liquidation, winding up, dissolution or any other change in the constitution of the Guarantor Bank.

THIS BANK GUARANTEE shall be a primary obligation of the Guarantor Bank and accordingly Nodal Agency shall not be obliged before enforcing this BANK GUARANTEE to take any action in any court or arbitral proceedings against [Insert name of the SPV] or the Selected Bidder, as the case may be, to make any claim against or any demand on [Insert name of the SPV] or the Selected Bidder, as the case may be, or to give any notice to [Insert name of the SPV] or the Selected Bidder, as the case may be, or to enforce any security held by the Nodal Agency or to exercise, levy or enforce any distress, diligence or other process against [Insert name of the SPV] or the Selected Bidder, as the case may be.

The Guarantor Bank acknowledges that this BANK GUARANTEE is not personal to Nodal Agency and may be assigned, in whole or in part, (whether absolutely or by way of security) by Nodal Agency to any entity to whom the Nodal Agency is entitled to assign its rights and obligations under the Transmission Service Agreement.

The Guarantor Bank hereby agrees and acknowledges that Nodal Agency shall have a right to invoke this Bank Guarantee either in part or in full, as it may deem fit.

Transmission Service Agreement

Notwithstanding anything contained hereinabove, our liability under this Guarantee is restricted to Rs. Crores (Rs.) only and it shall remain in force until[Date to be inserted on the basis of Article 3.1.2of the Transmission Service Agreement], with an additional claim period of three hundred sixty five (365) days thereafter. This BANK GUARANTEE shall be extended from time to time for such period, as may be desired by [Insert name of the Selected Bidder or Lead Member in case of the Consortium or SPV]. We are liable to pay the guaranteed amount or any part thereof under this Bank Guarantee only if Nodal Agency serves upon us a written claim or demand.

In witness where of:

Signature

Name:

Power of attorney No.:

For:

..... [Insert Name of the Bank]

Banker's Seal and Full Address, including mailing address of the Head Office

Schedule: 9**Methodology for determining the Relief Under Force Majeure Event & Change in Law during Construction Period**

The relief in the form of revision in tariff due to Force Majeure Event leading to extension of Scheduled COD for a period beyond one hundred eighty (180) days and/ or Change in Law during the construction period shall be as under:

$$\Delta T = [(P \times d)] \div [1 - (1 + d)^{-n}]$$

Where,

ΔT = Change in Transmission Charges for each year

P = Sum of cumulative increase or decrease in the cost of the Project due to Change in Law and interest cost during construction corresponding to the period exceeding one hundred eighty (180) due to Force Majeure Event leading to extension of Scheduled COD for a period beyond one hundred eighty (180) days

n = number of years over which the Transmission Charges has to be paid

d = 7.70 % (Discount rate as notified by the CERC, applicable on the Bid Deadline as per CERC notification dated 05.10.2023).

The increase in Transmission Charges as stated above shall be applicable only if the value of increase in Transmission Charges as calculated above exceeds 0.30% (zero point three percent) of the quoted Transmission Charges of the TSP.

Aditya Kislay

ANNEXURE P-15

From: TBCB Projects <tbc@recpdcl.in>
Sent: 09 February 2024 18:45
To: Wasim Alam; Aditya Kislay; Puneet Singh Chauhan
Cc: P S Hariharan; RECPDCL Satyabhan Sahoo Sir; Anil Kumar Perala; Ritam Biswas; Amit Chatterjee
Subject: RECPDCL:RFP dated 13.10.2023 for selection of Bidder as Transmission Service Provider for "Western Region Network Expansion Scheme in Kallam area of Maharashtra" through Tariff Based Competitive Bidding process.- Technically Qualified Bidders Regarding.
Attachments: Indigrid2 kallam.pdf

[Mail from External Sender - be careful with Links, Attachments and Responses.](#)

Sir,

Please find attached the RECPDCL letter dated 09.02.2024 on the subject cited project.

Thanks & Regards
Jitendra Singh,
TBCB Division,
RECPDCL



::DISCLAIMER::

The contents of this e-mail and any attachment(s) with it are confidential and intended for the sole use of named recipients and may contain legally confidential and / or privileged information. It shall not attach any liability on the originator. Any views or opinions presented in this email are solely those of the author and may not necessarily reflect the opinions of RECPDCL or its subsidiaries. If the reader of this message is not the intended recipient, immediately inform the originator by reply e-mail and delete this mail with all content and attachment(s). Any unauthorized reproduction, dissemination, copying, disclosure, modification, distribution and / or publication of this e-mail and attachment is strictly prohibited and may be unlawful. Before opening any mail and attachments please check them for viruses and defect. Email communications are not secure and capable of interception corruption and delays. Anyone communicating with the originator or RECPDCL or its subsidiaries by email accept the risk of email communication and their consequences.

534

REC Power Development and Consultancy Limited

(Formerly known as REC Power Distribution Company Limited,
A wholly owned subsidiary of REC Limited, a Maharatna CPSE
under Ministry of Power, Govt. of India)



Ref. No.: RECPDCL/ISTS/TBCB/Kallam/2023-24/ 4171

Date: 09.02.2024

Mr. Wasim Alam,
Senior Manager – Bidding & BD,
M/s IndiGrid 2 Limited,
Unit No 101, First Floor,
Windsor Village, KoleKalyan Off CST Road,
Vidyanagari Marg, Santacruz (East) Mumbai,
Maharashtra – 400098.

Subject: RFP dated 13.10.2023 for selection of Bidder as Transmission Service Provider for “Western Region Network Expansion Scheme in Kallam area of Maharashtra” through Tariff Based Competitive Bidding process.

Dear Sir,

We are thankful for your participation by submission of Response to RFP and pleased to inform you that pursuant to our evaluation, your response fulfills the qualification requirements as stipulated in the RFP and in accordance with Clause 3.2 to 3.4 you have been declared as “Qualified Bidder”.

We look forward for your participation.

Thanking you,

Yours faithfully,

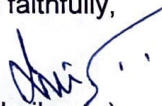
(P S Hariharan)

Chief General Manager (Tech)

ANNEXURE P/16 (COLLY.)

Date: 15.02.2024

CERTIFICATE BY BID EVALUATION COMMITTEE

Subject: Selection of Successful Bidder as Transmission Service Provider to establish Transmission System for "Western Region Network Expansion Scheme in Kallam area of Maharashtra" through tariff based competitive bidding process.

It is certified that:

- The entire bid process has been carried out in accordance with the "Tariff based Competitive Bidding Guidelines for Transmission Service" and "Guidelines for encouraging competition in development of the Transmission Projects" issued by Ministry of Power, Govt. of India under Section 63 of the Electricity Act, 2003 as amended from time to time.
- M/s Indgrid 2 Limited-M/s Indgrid 1 Limited (Consortium), with the lowest annual transmission charges of Rs. 152.50 Million, emerged as the successful Bidder after the conclusion of electronic reverse auction.
- The transmission charges of Rs. 152.50 Million discovered after electronic reverse auction is acceptable.



(Rajesh Kumar Singh)

General Manager,
CCGRO-II, SBI,
Chairman, BEC



(B S Bairwa)

Director (PSPA-II), CEA
Member, BEC



(B S Meena)

Director (PSETD), CEA
Member, BEC



(P D Lone)

SE, WRPC
Member, BEC



(Amit Naik)

SE (Systems), MSETCL
Member, BEC

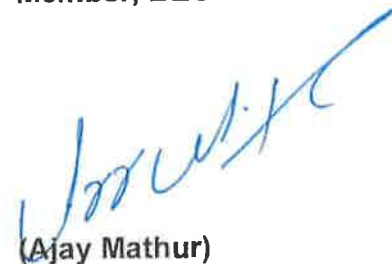

(Ajay Mathur)

Chairman, SPV
Convener – Member
BEC



भारत सरकार

Government of India

विद्युत मंत्रालय

Ministry of Power

केन्द्रीय विद्युत प्राधिकरण

Central Electricity Authority

विद्युत प्रणाली योजना एवं मूल्यांकन - I प्रभाग

Power System Planning & Appraisal-I Division

सेवा में /To,

Shri. P S Hariharan, Chief General Manager (Tech),
RECPDCL, D-Block, REC Headquarter, Plot No. I-4,

Sector-29, Gurugram (Haryana)- 122001

विषय/Subject: **Constitution of the Bid Evaluation Committee (BEC) for the transmission scheme "Western Region Network Expansion scheme in Kallam area of Maharashtra"- being implemented through TBCB -reg.**

संदर्भ / References:

- (i) Gazette of India (Extraordinary) issued on 10.08.2023
- (ii) M/s RECPDCL letter dated 15.12.2023

महोदय/ Sir,

Central Electricity Authority vide Gazette notification under reference (i) has notified the transmission scheme "Western Region Network Expansion scheme in Kallam area of Maharashtra" for implementation through tariff based competitive bidding (TBCB) with RECPDCL as the Bid Process Coordinator (BPC).

M/s RECPDCL vide its letter under reference (ii), requested CEA to constitute the Bid Evaluation Committee (BEC) for the above mentioned transmission scheme. Accordingly, CEA vide email dated 20.12.2023 sought nominations from WRPC for constitution of BEC.

Based on the nominations received from WRPC, the Bid Evaluation Committee (BEC) for evaluation of bids of the above mentioned transmission scheme is hereby constituted and is enclosed as **Annexure**. It may be mentioned that the Bid Evaluation Committee for the above mentioned transmission schemes have been constituted in line with

Clause 9.8 of the Tariff based Competitive Bidding Guidelines for Transmission Service issued on 10.08.2021.

संलग्न / Encl. - उपरोक्त / as above

भवदीय / Yours faithfully,

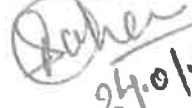
for 
24.01.2024

(ईशान शरण/ Ishan Sharan)
मुख्य अभियन्ता / Chief Engineer

Annexure**Bid Evaluation Committee (BEC) for “Western Region Network Expansion scheme in Kallam area of Maharashtra”:**

S. No.	Name	Designation
1.	Shri Rajesh Kumar Singh, General Manager, SBI Commercial Clients Group Regional Office -II, New Delhi	Chairman
2.	Shri P.D. Lone, Superintending Engineer, WRPC	Member
3.	Shri Amit Naik, Superintending Engineer(Systems), MSETCL	Member
4.	Director, PSPA-II Division, CEA [Shri B. S. Bairwa]	Member
5.	Director, PSETD Division, CEA [Shri Bhanwar Singh Meena]	Member
6.	Chairman of SPV constituted by RECPDCL	Convener -Member

Ref No.: RECPDCL/TBCB/Kallam/2023-24/4287

Date: 15.02.2024

To,
**M/s Indigrd 2 Limited (Lead Member) and
Indigrd 1 Limited (Other Member) – Consortium**
Unit No 101, 1st Floor Windsor Village,
Kole Kalyan Off CST Road
Vidya Nagari Marg, Santacruz (East)
Mumbai, Maharastra-400098.

Kind Attention: Mr. Wasim Alam, Sr. Manager (Bidding & BD)

Subject: Establishment of "Western Region Network Expansion Scheme in Kallam area of Maharashtra" through Tariff Based Competitive Bidding Process (TBCB) – **Letter of Intent.**

Dear Sir,

We refer to:

1. The Request for Proposal (RfP) dated 13.10.2023 comprising RfP, Draft Transmission Service Agreement & Share Purchase Agreement and Survey Report dated 27.10.2023 issued to Consortium of M/s Indigrd 2 Limited (Lead Member) and Indigrd 1 Limited (Other Member), as regards participation in the Global Invitation for Bids for establishment of "Western Region Network Expansion Scheme in Kallam area of Maharashtra" through Tariff Based Competitive Bidding process including all correspondence/clarifications/amendments/Errata/corrigendum issued by REC Power Development and Consultancy Limited in regard thereto (hereinafter collectively referred to as the 'Final RFP') till the submission Bid Deadline and as listed below:
 - (i) Amendment-I dated 15.12.2023,
 - (ii) Amendment-II and Clarifications dated 27.12.2023,
 - (iii) Amendment-III dated 04.01.2024,
 - (iv) Amendment-IV and Additional Clarifications dated 15.01.2024,
 - (v) Additional Clarifications dated 16.01.2024
2. The offer of M/s Indigrd 2 Limited (Lead Member) and Indigrd 1 Limited (Other Member)- Consortium by way of a Technical Bid pursuant to (1) above submitted on 19.01.2024 in response to the Final RFP.
3. The Initial Price Offer of M/s Indigrd 2 Limited (Lead Member) and Indigrd 1 Limited (Other Member)- Consortium as submitted on 19.01.2024 in response to the Final RFP.
4. The final offer of M/s Indigrd 2 Limited (Lead Member) and Indigrd 1 Limited (Other Member)- Consortium (which was same as of Initial Price Offer after conclusion of e-Reverse Auction Process), discovered during e-Reverse Auction, conducted on 13.02.2024 in response to the Final RFP.
5. The Technical Bid as in (2) above, the Initial Price Offer as in (3) above and the Final Offer as in (4) above hereinafter collectively referred to as the 'Bid'.

Page 1 of 4



We are pleased to inform you that your proposal and offer received by way of the 'Bid' has been accepted and M/s Indigrd 2 Limited (Lead Member) & Indigrd 1 Limited (Other Member)- Consortium is here by declared as Successful Bidder as per clause 3.6.1 of the Final RFP for the above project and consequently, this Letter of Intent (hereinafter referred to as the 'Lol') is being issued in 2 copies, One original plus One copy.

This Lol is based on the Final RFP and is further contingent upon you satisfying the following conditions:

- (a) Acknowledging its issuance and unconditionally accepting its contents and recording 'Accepted unconditionally' under the signature and stamp of your authorized signatory on each page of the duplicate copy of this letter attached herewith and returning the same to REC Power Development and Consultancy Limited within 7 (Seven) days from the date of issuance of Lol.
- (b) Completion of various activities as stipulated in the RFP including in particular Clause 2.15.2, Clause 2.15.3 and Clause 2.15.4 of the Final RFP within the timelines as prescribed therein.
- (c) Provide the Contract Performance Guarantee of Rs. 3.00 Crore (Rupees Three Crore Only) within 10 (Ten) days from issue of this Lol, in favour of the Central "Transmission Utility of India Limited, as per the provisions of Clause 2.12.

It may be noted that REC Power Development and Consultancy Limited has the rights available to them under the Final RFP, including rights under clause 2.15.5 and 3.6.3 thereof, upon your failure to comply with the aforementioned conditions.

As you are aware, the issuance and contents of this Lol are based on the Bid submitted by you as per the Final RFP including the Transmission Charges and other details regarding the Scheduled COD as contained therein.

The Quoted Transmission Charges as submitted by you and the Scheduled COD of transmission elements as agreed by you in your Bid, as per Annexure 21 and Format-1 of Annexure-8 respectively of the Final RFP is enclosed herewith as Schedule-A and incorporated herein by way of reference.

Further, please note that relationship of M/s Indigrd 2 Limited (Lead Member) and Indigrd 1 Limited (Other Member)- Consortium with the REC Power Development and Consultancy Limited & Central Transmission Utility of India Limited will be governed solely on the basis of the Final RFP.

You are requested to unconditionally accept the Lol, and record on one copy of the Lol, 'Accepted unconditionally', under the signature of the authorized signatory of your Company and return such copy to us within 7 (Seven) days of issue of Lol.

Yours faithfully

f

 (P S Hariharan)
 Chief General Manager (Tech)

Enclosures:

1. Schedule A: Quoted Transmission Charges and the scheduled COD of transmission element submitted in your Bid, as per Annexure 21 and Format-1 of Annexure-8 respectively of the Final RFP.

Copy for kind information to:

1. **The Secretary,**
Central Electricity Regulatory Commission,
3 & 4 Floor, Chandra Lok Building,
Janpath, New Delhi-110001.
2. **The Chairperson,**
Central Electricity Authority,
Sewa Bhawan, R K Puram,
New Delhi-110086.
3. **The Joint Secretary (Transmission),**
Ministry of Power,
Shram Shakti Bhawan,
Rafi Marg, New Delhi- 110 004.
4. **The Director (Transmission),**
Ministry of Power, Govt, of India,
Shram Shakti Bhawan, Raft Marg,
New Delhi 1 10001
5. **The Chief Engineer (PSP & PA -I)**
Central Electricity Authority,
Sewa Bhawan, R.K. Puram,
New Delhi – 110066.
6. **The Chief Operating Officer**
Central Transmission Utility of India Limited,
Power Grid Corporation of India Ltd.,
" Saudamini", Plot No 2 Sector – 29,
Gurgaon – 122001.



ANNEXURE 21 - FORMAT FOR FINANCIAL BID

Quoted Annual Transmission Charges: Rs. 152.50 Million

Notes:

1. The Bidders are required to ensure compliance with the provisions of Clause 2.5.3 of this RFP.
2. Quotes to be in Rupees Millions and shall be up to two (2) decimal points.
3. The contents of this format shall be clearly typed.
4. The Financial Bid shall be digitally signed by the authorized signatory in whose name power of attorney as per Clause 2.5.2 is issued.
5. Ensure only one value for annual Transmission Charges is quoted. The same charge shall be payable every year to TSP for the term of TSA.

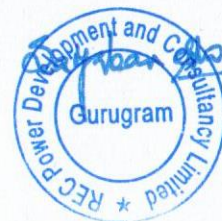

Annexure 8- Undertaking And Details Of Equity Investment

Format 1: Bidders' Undertakings

Date: 17.01.2024

To,
Chief Executive Officer,
REC Power Development and Consultancy Limited
 (formerly REC Power Distribution Company Limited)
 (A wholly owned subsidiary of REC Limited)
REC Corporate Head Quarter,
D Block, Plot No. I – 4, Sec – 29 Gurugram – 122 001

Dear Sir,

Sub: Bidders' Undertakings in respect of Bid for selection of Bidder as TSP to establish Inter-State transmission system for "Western Region Network Expansion scheme in Kallam area of Maharashtra"

We hereby undertake on our own behalf and on behalf of the TSP, that if selected as the Successful Bidder for the Project:

1. The Project shall comply with all the relevant electricity laws, codes, regulations, standards and Prudent Utility Practices, environment laws and relevant technical, operational and safety standards, and we shall execute any agreements that may be required to be executed as per law in this regard.
2. We confirm that the Project shall also comply with the standards and codes as per Clause 1.6.1.2 of the RFP and the TSP shall comply with the provisions contained in the Central Electricity Regulatory Commission Grant of Connectivity, Long-term Access and Medium-term Open Access in inter-state Transmission and related matters Open Access) Regulations, 2009.
3. We give our unconditional acceptance to the **RFP dated 13.10.2023** issued by the BPC and the RFP Project Documents, as amended, and undertake to ensure that the TSP shall execute all the RFP Project Documents, as per the provisions of this RFP.
4. We have submitted the Bid on the terms and conditions contained in the RFP and the RFP Project Documents. Further, the Financial Bid submitted by us is strictly as per the format provided in Annexure 21 of the RFP, without mentioning any deviations, conditions, assumptions or notes in the said Annexure.
5. Our Bid is valid up to the period required under Clause 2.8 of the RFP.
6. Our Bid has been duly signed by authorized signatory and stamped in the manner and to the extent indicated in this RFP and the power of attorney / Board resolution in requisite format as per RFP has been enclosed with this undertaking.

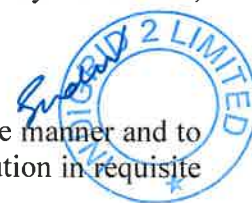

7. We have assumed that if we are selected as the Successful Bidder, the provisions of the Consortium Agreement, to the extent and only in relation to equity lock in and our liability thereof shall get modified to give effect to the provisions of Clause 2.5.8 of this RFP and Article 18.1 of the Transmission Service Agreement. *(Note: This is applicable only in case of a Bidding Consortium)*
8. We confirm that our Bid meets the Scheduled COD of each transmission Element and the Project as specified below:

Sl. No.	Name of the Transmission Element	Scheduled COD	Percentage of Quoted Transmission Charges recoverable on Scheduled COD of the Element of the Project	Element(s) which are pre-required for declaring the commercial operation (COD) of the respective Element
1.	LILO of both circuits of Parli(M) – Karjat(M)/Lonikand-II (M) 400 kV D/c line (twin moose) at Kallam PS	18 months from date of SPV acquisition	100%	All Elements are required to be commissioned simultaneously as their utilization is dependent on commissioning of each other.
2.	4 Nos. 400 kV line bays at Kallam PS for LILO of both circuits of Parli(M) – Karjat(M)/Lonikand-II(M) 400 kV D/c line (twin moose) at Kallam PS			
3.	63 MVAR, 420 kV switchable line reactor (with NGR bypassing arrangement) on each ckt at Kallam PS end of Karjat – Kallam 400 kV D/c line (~140km.)			

We agree that the payment of Transmission Charges for any Element irrespective of its successful commissioning on or before its Scheduled COD shall only be considered after the successful commissioning of Element(s) which are pre - required for declaring the commercial operation of such Element as mentioned in the above table.

Scheduled COD for the Project: 18 months from the date of SPV Transfer.

9. We confirm that our Financial Bid conforms to all the conditions mentioned in this RFP, and in particular, we confirm that:
- Financial Bid in the prescribed format of Annexure 21 has been submitted duly signed by the authorized signatory.
 - Financial Bid is unconditional.
 - Only one Financial Bid has been submitted.
10. We have neither made any statement nor provided any information in this Bid, which to the best of our knowledge is materially inaccurate or misleading. Further, all the confirmations, declarations and representations made in our Bid are true and accurate. In case this is found to be incorrect after our acquisition of **Kallam Transco Limited**, pursuant to our selection as Selected Bidder, we agree that the same would be treated as a TSP's Event of Default under Transmission Service Agreement, and relevant provisions of Transmission Service Agreement shall apply.
11. We confirm that there are no litigations or other disputes against us which materially affect our ability to fulfill our obligations with regard to the Project as per the terms of RFP Project Documents.
12. Power of attorney/ Board resolution as per Clause 2.5.2 is enclosed.

Signature and name of the authorized signatory of the Company and stamp of Bidding Company or Lead member of Consortium

Sudhir
 Name: **Sudhir Nayak**

Designation: **Manager**

Address: **IndiGrid 2 Limited**

**Unit No. 101, First Floor, Windsor, Village KoleKalyan, off CST Road,
 Vidyanagari Marg, Kalina, Santacruz (East), Mumbai – 400 098**

Date: *17.01.2024*

Place: *Delhi*

Company Rubber Stamp

Note:

- In case of foreign Bidders, refer to clause 2.5.6 (p)

546 ANNEXURE P/18

Aditya Kislay

From: Wasim Alam
Sent: 16 February 2024 17:00
To: TBCB Projects
Cc: RECPDCL Satyabhan Sahoo Sir; P S Hariharan; Ritam Biswas; Amit Chatterjee; Puneet Singh Chauhan; Ankit Kumar; Anil Kumar Perala; Aditya Kislay
Subject: RE: RECPDCL: Letter of Intent (LoI) for Establishment of Western Region Network Expansion Scheme in Kallam area of Maharashtra- Regarding
Attachments: KALLAM EXPANSION_Accepted LOI.pdf

General

To,
Chief Executive Officer,
REC Power Development and Consultancy Limited
(formerly REC Power Distribution Company Limited)
(A wholly owned subsidiary of REC Limited)
REC Corporate Head Quarter,
D Block, Plot No. I – 4, Sec – 29 Gurugram – 122 001

Dear Sir,

Sub: Establishment of “**Western Region Network Expansion scheme in Kallam area of Maharashtra**” through **Tariff Based Competitive Bidding (TBCB)-Letter of Intent.**

We on behalf of M/s **IndiGrid 2 Limited (Lead Member) and IndiGrid 1 Limited (Other Member) (Bidding Consortium)** (hereinafter called the “Bidder”) **unconditionally accepted the conditions of Letter of Intent (LOI)** as issued by your good office *vide official letter reference no. RECPDCL/TBCB/Kallam/2023-24/4287 dated: 15.02.2024.*

This is for your kind reference.

Note: Hard copy of LOI duly signed and stamp by authorized signatory of company, will submit to your good office.

Thanks & Regards,
Wasim Alam
Senior Manager - Bidding & Business Development



IndiGrid Limited
10th Floor, Berger Tower
Delhi One Complex, Sector-16 B
Noida, Uttar Pradesh-201301 (INDIA)
Email : wasim.alam1@indigrd.com
Mob : +91-9205620636

From: TBCB Projects <tbc@recpdcl.in>
Sent: Thursday, February 15, 2024 9:41 PM

To: Wasim Alam <wasim.alam1@indigrid.com>; Aditya Kislay <aditya.kislay@indigrid.com>; Puneet Singh Chauhan <puneet.chauhan@indigrid.com>

Cc: RECPDCL Satyabhan Sahoo Sir <satyabhan.sahoo@recpdcl.in>; P S Hariharan <pshariharan@recpdcl.in>; Ritam Biswas <ritam.biswas@recpdcl.in>; Amit Chatterjee <amit.chatterjee@recpdcl.in>; Ankit Kumar <ankit.kumar@recpdcl.in>; Anil Kumar Perala <anilkperala@recpdcl.in>

Subject: RECPDCL: Letter of Intent (LoI) for Establishment of Western Region Network Expansion Scheme in Kallam area of Maharashtra- Regarding

[Mail from External Sender - be careful with Links, Attachments and Responses.](#)

Sir,

Please find attached the LoI dated 15.02.2024 issued to **M/s Indigrid 2 Limited (Lead Member) and Indigrid 1 Limited (Other Member) – Consortium** for the subject cited project.

Thanks & Regards,
Ritam Biswas
AM (Eng.),
TBCB Division, RECPDCL



::DISCLAIMER::

The contents of this e-mail and any attachment(s) with it are confidential and intended for the sole use of named recipients and may contain legally confidential and / or privileged information. It shall not attach any liability on the originator. Any views or opinions presented in this email are solely those of the author and may not necessarily reflect the opinions of RECPDCL or its subsidiaries. If the reader of this message is not the intended recipient, immediately inform the originator by reply e-mail and delete this mail will all content and attachment(s) . Any unauthorized reproduction, dissemination, copying, disclosure, modification, distribution and / or publication of this e-mail and attachment is strictly prohibited and may be unlawful. Before opening any mail and attachments please check them for viruses and defect. Email communications are not secure and capable of interception corruption and delays. Anyone communicating with the originator or RECPDCL or its subsidiaries by email accept the risk of email communication and their consequences.

Ref No.: RECPDCL/TBCB/Kallam/2023-24/4287

Date: 15.02.2024

To,
**M/s Indigrd 2 Limited (Lead Member) and
Indigrd 1 Limited (Other Member) – Consortium**
Unit No 101, 1st Floor Windsor Village,
Kole Kalyan Off CST Road
Vidya Nagari Marg, Santacruz (East)
Mumbai, Maharastra-400098.

Kind Attention: Mr. Wasim Alam, Sr. Manager (Bidding & BD)

Subject: Establishment of "Western Region Network Expansion Scheme in Kallam area of Maharashtra" through Tariff Based Competitive Bidding Process (TBCB) – **Letter of Intent.**

Dear Sir,

We refer to:

1. The Request for Proposal (RfP) dated 13.10.2023 comprising RfP, Draft Transmission Service Agreement & Share Purchase Agreement and Survey Report dated 27.10.2023 issued to Consortium of M/s Indigrd 2 Limited (Lead Member) and Indigrd 1 Limited (Other Member), as regards participation in the Global Invitation for Bids for establishment of "Western Region Network Expansion Scheme in Kallam area of Maharashtra" through Tariff Based Competitive Bidding process including all correspondence/clarifications/amendments/Errata/corrigendum issued by REC Power Development and Consultancy Limited in regard thereto (hereinafter collectively referred to as the 'Final RFP') till the submission Bid Deadline and as listed below:
 - (i) Amendment-I dated 15.12.2023,
 - (ii) Amendment-II and Clarifications dated 27.12.2023,
 - (iii) Amendment-III dated 04.01.2024,
 - (iv) Amendment-IV and Additional Clarifications dated 15.01.2024,
 - (v) Additional Clarifications dated 16.01.2024
2. The offer of M/s Indigrd 2 Limited (Lead Member) and Indigrd 1 Limited (Other Member)- Consortium by way of a Technical Bid pursuant to (1) above submitted on 19.01.2024 in response to the Final RFP.
3. The Initial Price Offer of M/s Indigrd 2 Limited (Lead Member) and Indigrd 1 Limited (Other Member)- Consortium as submitted on 19.01.2024 in response to the Final RFP.
4. The final offer of M/s Indigrd 2 Limited (Lead Member) and Indigrd 1 Limited (Other Member)- Consortium (which was same as of Initial Price Offer after conclusion of e-Reverse Auction Process), discovered during e-Reverse Auction, conducted on 13.02.2024 in response to the Final RFP.
5. The Technical Bid as in (2) above, the Initial Price Offer as in (3) above and the Final Offer as in (4) above hereinafter collectively referred to as the 'Bid'.



We are pleased to inform you that your proposal and offer received by way of the 'Bid' has been accepted and M/s Indigrd 2 Limited (Lead Member) & Indigrd 1 Limited (Other Member)- Consortium is here by declared as Successful Bidder as per clause 3.6.1 of the Final RFP for the above project and consequently, this Letter of Intent (hereinafter referred to as the 'Lol') is being issued in 2 copies, One original plus One copy.

This Lol is based on the Final RFP and is further contingent upon you satisfying the following conditions:

- (a) Acknowledging its issuance and unconditionally accepting its contents and recording 'Accepted unconditionally' under the signature and stamp of your authorized signatory on each page of the duplicate copy of this letter attached herewith and returning the same to REC Power Development and Consultancy Limited within 7 (Seven) days from the date of issuance of Lol.
- (b) Completion of various activities as stipulated in the RFP including in particular Clause 2.15.2, Clause 2.15.3 and Clause 2.15.4 of the Final RFP within the timelines as prescribed therein.
- (c) Provide the Contract Performance Guarantee of Rs. 3.00 Crore (Rupees Three Crore Only) within 10 (Ten) days from issue of this Lol, in favour of the Central "Transmission Utility of India Limited, as per the provisions of Clause 2.12.

It may be noted that REC Power Development and Consultancy Limited has the rights available to them under the Final RFP, including rights under clause 2.15.5 and 3.6.3 thereof, upon your failure to comply with the aforementioned conditions.

As you are aware, the issuance and contents of this Lol are based on the Bid submitted by you as per the Final RFP including the Transmission Charges and other details regarding the Scheduled COD as contained therein.

The Quoted Transmission Charges as submitted by you and the Scheduled COD of transmission elements as agreed by you in your Bid, as per Annexure 21 and Format-1 of Annexure-8 respectively of the Final RFP is enclosed herewith as Schedule-A and incorporated herein by way of reference.

Further, please note that relationship of M/s Indigrd 2 Limited (Lead Member) and Indigrd 1 Limited (Other Member)- Consortium with the REC Power Development and Consultancy Limited & Central Transmission Utility of India Limited will be governed solely on the basis of the Final RFP.

You are requested to unconditionally accept the Lol, and record on one copy of the Lol, 'Accepted unconditionally', under the signature of the authorized signatory of your Company and return such copy to us within 7 (Seven) days of issue of Lol.

Yours faithfully

f Satyaran dho
(P S Hariharan)
Chief General Manager (Tech)

Enclosures:

1. Schedule A: Quoted Transmission Charges and the scheduled COD of transmission element submitted in your Bid, as per Annexure 21 and Format-1 of Annexure-8 respectively of the Final RFP.

Unconditionally Accepted



Copy for kind information to:

1. **The Secretary,**
Central Electricity Regulatory Commission,
3 & 4 Floor, Chandra Lok Building,
Janpath, New Delhi-110001.
2. **The Chairperson,**
Central Electricity Authority,
Sewa Bhawan, R K Puram,
New Delhi-110086.
3. **The Joint Secretary (Transmission),**
Ministry of Power,
Shram Shakti Bhawan,
Rafi Marg, New Delhi- 110 004.
4. **The Director (Transmission),**
Ministry of Power, Govt, of India,
Shram Shakti Bhawan, Raft Marg,
New Delhi 1 10001
5. **The Chief Engineer (PSP & PA -I)**
Central Electricity Authority,
Sewa Bhawan, R.K. Puram,
New Delhi – 110066.
6. **The Chief Operating Officer**
Central Transmission Utility of India Limited,
Power Grid Corporation of India Ltd.,
" Saudamini", Plot No 2 Sector – 29,
Gurgaon – 122001.



Unconditionally Accepted



ANNEXURE 21 - FORMAT FOR FINANCIAL BID**Quoted Annual Transmission Charges: Rs. 152.50 Million****Notes:**

1. The Bidders are required to ensure compliance with the provisions of Clause 2.5.3 of this RFP.
2. Quotes to be in Rupees Millions and shall be up to two (2) decimal points.
3. The contents of this format shall be clearly typed.
4. The Financial Bid shall be digitally signed by the authorized signatory in whose name power of attorney as per Clause 2.5.2 is issued.
5. Ensure only one value for annual Transmission Charges is quoted. The same charge shall be payable every year to TSP for the term of TSA.



Unconditionally Accepted



Annexure 8- Undertaking And Details Of Equity Investment

Format 1: Bidders' Undertakings

Date: 17.01.2024

To,
Chief Executive Officer,
REC Power Development and Consultancy Limited
 (formerly REC Power Distribution Company Limited)
 (A wholly owned subsidiary of REC Limited)
REC Corporate Head Quarter,
D Block, Plot No. I – 4, Sec – 29 Gurugram – 122 001

Dear Sir,

Sub: Bidders' Undertakings in respect of Bid for selection of Bidder as TSP to establish Inter-State transmission system for "Western Region Network Expansion scheme in Kallam area of Maharashtra"

We hereby undertake on our own behalf and on behalf of the TSP, that if selected as the Successful Bidder for the Project:

1. The Project shall comply with all the relevant electricity laws, codes, regulations, standards and Prudent Utility Practices, environment laws and relevant technical, operational and safety standards, and we shall execute any agreements that may be required to be executed as per law in this regard.
2. We confirm that the Project shall also comply with the standards and codes as per Clause 1.6.1.2 of the RFP and the TSP shall comply with the provisions contained in the Central Electricity Regulatory Commission Grant of Connectivity, Long-term Access and Medium-term Open Access in inter-state Transmission and related matters Open Access) Regulations, 2009.
3. We give our unconditional acceptance to the **RFP dated 13.10.2023** issued by the BPC and the RFP Project Documents, as amended, and undertake to ensure that the TSP shall execute all the RFP Project Documents, as per the provisions of this RFP.
4. We have submitted the Bid on the terms and conditions contained in the RFP and the RFP Project Documents. Further, the Financial Bid submitted by us is strictly as per the format provided in Annexure 21 of the RFP, without mentioning any deviations, conditions, assumptions or notes in the said Annexure.
5. Our Bid is valid up to the period required under Clause 2.8 of the RFP.
6. Our Bid has been duly signed by authorized signatory and stamped in the manner and to the extent indicated in this RFP and the power of attorney / Board resolution in requisite format as per RFP has been enclosed with this undertaking.

Unconditionally Accepted





7. We have assumed that if we are selected as the Successful Bidder, the provisions of the Consortium Agreement, to the extent and only in relation to equity lock in and our liability thereof shall get modified to give effect to the provisions of Clause 2.5.8 of this RFP and Article 18.1 of the Transmission Service Agreement. *(Note: This is applicable only in case of a Bidding Consortium)*
8. We confirm that our Bid meets the Scheduled COD of each transmission Element and the Project as specified below:

Sl. No.	Name of the Transmission Element	Scheduled COD	Percentage of Quoted Transmission Charges recoverable on Scheduled COD of the Element of the Project	Element(s) which are pre-required for declaring the commercial operation (COD) of the respective Element
1.	LILO of both circuits of Parli(M) – Karjat(M)/Lonikand-II (M) 400 kV D/c line (twin moose) at Kallam PS	18 months from date of SPV acquisition	100%	All Elements are required to be commissioned simultaneously as their utilization is dependent on commissioning of each other.
2.	4 Nos. 400 kV line bays at Kallam PS for LILO of both circuits of Parli(M) – Karjat(M)/Lonikand-II(M) 400 kV D/c line (twin moose) at Kallam PS			
3.	63 MVAR, 420 kV switchable line reactor (with NGR bypassing arrangement) on each ckt at Kallam PS end of Karjat – Kallam 400 kV D/c line (~140km.)			

We agree that the payment of Transmission Charges for any Element irrespective of its successful commissioning on or before its Scheduled COD shall only be considered after the successful commissioning of Element(s) which are pre - required for declaring the commercial operation of such Element as mentioned in the above table.

Unconditionally
Accepted



Registered & Corporate Office: Plot No. 101, First Floor, Windsor, Village Kelo-Kalyan Off GST Road, IndiGrid 2 Limited, Ghatghar (E. City),
Mumbai, Maharashtra-400098, India | CIN: U29130MH2014PLC353042
Email: complianceofficer@indigrd.co.in | www.indigrd.co.in | Ph: +91 70284 93885



Scheduled COD for the Project: 18 months from the date of SPV Transfer.

9. We confirm that our Financial Bid conforms to all the conditions mentioned in this RFP, and in particular, we confirm that:
- Financial Bid in the prescribed format of Annexure 21 has been submitted duly signed by the authorized signatory.
 - Financial Bid is unconditional.
 - Only one Financial Bid has been submitted.
10. We have neither made any statement nor provided any information in this Bid, which to the best of our knowledge is materially inaccurate or misleading. Further, all the confirmations, declarations and representations made in our Bid are true and accurate. In case this is found to be incorrect after our acquisition of **Kallam Transco Limited**, pursuant to our selection as Selected Bidder, we agree that the same would be treated as a TSP's Event of Default under Transmission Service Agreement, and relevant provisions of Transmission Service Agreement shall apply.
11. We confirm that there are no litigations or other disputes against us which materially affect our ability to fulfill our obligations with regard to the Project as per the terms of RFP Project Documents.
12. Power of attorney/ Board resolution as per Clause 2.5.2 is enclosed.

Signature and name of the authorized signatory of the Company and stamp of Bidding Company or Lead member of Consortium

Sudhir

Name: **Sudhir Nayak**

Designation: **Manager**

Address: **IndiGrid 2 Limited**

**Unit No. 101, First Floor, Windsor, Village KoleKalyan, off CST Road,
Vidyanagari Marg, Kalina, Santacruz (East), Mumbai – 400 098**

Date: *17.01.2024*

Place: *Delhi*

Company Rubber Stamp



Unconditionally Accepted



Note:

- In case of foreign Bidders, refer to clause 2.5.6 (p)

REC Power Development and Consultancy Limited

(Formerly known as REC Power Distribution Company Limited,
A wholly owned subsidiary of REC Limited, a Maharatna CPSE
under Ministry of Power, Govt. of India)



Ref No: RECPDCL/TBCB/Kallam/2024-25/47

Date: 05.04.2024

M/s IndiGrid 2 Limited,
Unit No 101, First Floor,
Windsor Village, KoleKalyan Off CST Road,
Vidyanagari Marg, Santacruz (East) Mumbai,
Maharashtra – 400098.

Sub: Establishment of Transmission System for “Western region Network Scheme in Kallam area of Maharashtra” through tariff based competitive bidding process – Extension of Lol- regarding.

Ref.: RECPDCL/TBCB/Kallam/2023-24/4287, Dated 15.02.2024

Dear Sir,

This is in reference to above referred Letter of Intent dated 15th February, 2024 issued to M/s IndiGrid 2 Limited for Western region Network Scheme in Kallam area of Maharashtra.

To complete the activities mentioned under Clause 2.15.2, Clause no. 2.15.3 and Clause no. 2.15.4 of Request for Proposal (RFP) document, the last date for completion of various activities, is extended till 15th April, 2024.

Thanking You,

Yours faithfully,

A handwritten signature in blue ink, appearing to read "P S Hariharan".

(P S Hariharan)

Chief General Manager (Tech)

ANNEXURE P/20

Aparajita Upadhyay

From: TBCB Projects <tbc@recpdcl.in>
Sent: 16 February 2024 10:42
To: Wasim Alam; Aditya Kislay; Puneet Singh Chauhan
Cc: P S Hariharan; RECPDCL Satyabhan Sahoo Sir; Arvind Kumar; Ankit Kumar; Anil Kumar Perala; Ritu Madan Arora; Ritam Biswas; CS Division RECPDCL; Dillip Kumar Rout; Finance Division RECPDCL
Subject: Due Diligence of Kallam Transco Limited - Regarding

[Mail from External Sender - be careful with Links, Attachments and Responses.](#)

Dear Sir,

It is to inform you that the due-diligence in respect of Kallam Transco Limited shall be held on 20.02.2024 (Tuesday), 11:00 Hrs onwards.

You are requested to kindly depute your team (Technical, Finance & CS) to our office for carrying out due diligence, so as to ensure smooth transfer of SPV.

In case of any query please feel free to contact undersigned.

Thanks & Regards,

Shashank Singh
Mob:8563882022
TBCB Division,
RECPDCL



::DISCLAIMER::

The contents of this e-mail and any attachment(s) with it are confidential and intended for the sole use of named recipients and may contain legally

confidential and / or privileged information. It shall not attach any liability on the originator. Any views or opinions presented in this email are solely those of the author and may not necessarily reflect the opinions of RECPDCL or its subsidiaries. If the reader of this message is not the intended recipient, immediately inform the originator by reply e-mail and delete this mail will all content and attachment(s) . Any unauthorized reproduction, dissemination, copying, disclosure, modification, distribution and / or publication of this e-mail and attachment is strictly prohibited and may be unlawful. Before opening any mail and attachments please check them for viruses and defect. Email communications are not secure and capable of interception corruption and delays. Anyone communicating with the originator or RECPDCL or its subsidiaries by email accept the risk of email communication and their consequences.

558
ANNEXURE P/21

No. 27-44/1/2024-REC DESK
Government of India
Ministry of Power

Shram Shakti Bhawan, Rafi Marg,
New Delhi, dated the 26th March, 2024

To

The Chairman & Managing Director,
REC Limited, Plot No. I-4, Sector-29,
Gurugram, Haryana -122001.

Subject: Approval for Sale and transfer of Kallam Transco Limited to the consortium of M/s Indigrd 2 Limited (Lead) and Indigrd 1 Limited (Other)- – Regarding.

Sir,

I am directed to refer to RECPDCL's letter SEC No.1/219/2024/4542 dated 5th March, 2024 on the subject mentioned above and to convey the approval of competent authority for sale and transfer of 50,000 equity shares of Rs. 10 each of Kallam Transco Limited to the Successful Bidder, selected through Tariff Based Competitive Bidding Process i.e the Consortium of M/s Indigrd 2 Limited (Lead) and Indigrd 1 Limited (Other).

Yours faithfully,

C. Thenmoli
26/3/2024
(C. Thenmoli)

Under Secretary to the Govt. of India
Tel.: 011-23711302

Copy for information and necessary action to:

1. US (Trans), MoP. with the request that transmission wing should also write to concerned states informing about the project for extending all possible help in assessment of compensation to be paid to landowners and also expediting forest clearance, if involved in the project.
2. CEO, RECPDCL

Aparajita Upadhyay

Subject: RE: RECPDCL: Final Acquisition Price of Kallam Transco Limited and SPV Transfer -Regarding.

From: TBCB Projects <tcb@recpdcl.in>

Sent: Wednesday, March 27, 2024 7:05 PM

To: Wasim Alam <wasim.alam1@indigrid.com>; Aditya Kislay <aditya.kislay@indigrid.com>; Puneet Singh Chauhan <puneet.chauhan@indigrid.com>

Cc: Deepak Krishnan [दीपक कृष्णन] <deepakkrishnan@powergrid.in>; P S Hariharan <pshariharan@recpdcl.in>; RECPDCL Satyabhan Sahoo Sir <satyabhan.sahoo@recpdcl.in>; Ankit Kumar <ankit.kumar@recpdcl.in>; Anil Kumar Perala <anilkperala@recpdcl.in>; Ritam Biswas <ritam.biswas@recpdcl.in>; AMIT CHATTERJEE <amitchatterjee141985@gmail.com>

Subject: RECPDCL: Final Acquisition Price of Kallam Transco Limited and SPV Transfer -Regarding.

Mail from External Sender - be careful with Links, Attachments and Responses.

Sir,

Please find enclosed our office letter dated 27.03.2024 in respect of Final Acquisition Price of Kallam Transco Limited. The date of transfer of subject SPV shall be 05.04.2024.

In respect of CPG & TSA finalization and execution, please contact Mr. Deepak Krishnan, Manager(Technical), CTUIL under intimation to us.

Thanks & Regards

Kshitez Arora

TBCB Division

RECPDCL



::DISCLAIMER::

Ref No.: REC PDCL/Fin/KTL/2024/4848

Dated: 27.03.2024

To,
MIs Indigrid 2 Limited (Lead Member) and
Indigrid 1 Limited (Other Member)-Consortium,
Unit No 1, 1 SI Floor Windsor Village,
Kole Kalyan Off CST Road
Vidya Nagari Marg, Santacruz (East)
Mumbai, Maharashtra-400098.

Kind Attention: Mr. Wasim Alam, Sr. Manager (Bidding & BD)

Subject: Payment of Acquisition Price towards handing over of M/s. KALLAM TRANSCO LIMITED.

Sir,

This is to inform that the acquisition price of M/s. Kallam Transco Limited is **Rs 6,46,63,522/- (Rupees Six Crore Forty Six Lakhs Sixty Three Thousand Five Hundred Twenty Two Only)** as per the breakup given below:

S No	Particulars	Amount (INR)
1	Professional Fee of BPC #	5,90,00,000
2	Reimbursement of cost incurred by BPC #	50,36,140
3	Interest Cost	1,27,382
4	Share Capital of Kallam Transco Ltd	5,00,000
Acquisition Value/ Net Amount Payable by Bidder		6,46,63,522

including GST

Kindly credit the above total amount i.e., **Rs. 6,46,63,522/-** in the below mentioned Bank Account of REC Power Development and Consultancy Limited. TDS will be deposited by RECPDCL on behalf and under TAN of Kallam Transco Limited.

The acquisition price may be credited to our account through RTGS as per the following:

Bank Name, Address & Branch	IDFC First Bank Limited SOODH & BIRLA TOWERS, 4TH FLOOR EAST TOWER & LGF WEST TOWER, BARAKHAMBHA ROAD, NEW DELHI -110001
Bank Account Name	REC Power Development & Consultancy Limited
Bank Account No	10000697415
Bank IFSC Code No	IDFB0020101

Thanking You,

Yours faithfully

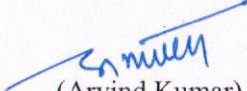
(Arvind Kumar)
GM (F&A)



562
ANNEXURE P/23 (COLLY.)

Date: 04-04-2024
Ref: 0555NDLG00000925

To,
CENTRAL TRANSMISSION UTILITY OF INDIA LIMITED
CTUIL SAUDAMINI FIRST FLOOR PLOT NO 2
SECTOR 29 GURUGRAM

GURUGRAM
HARYANA
INDIA
122001

Sub: Issuance of Bank Guarantee

Dear Sir/Madam,

Please find enclosed Bank Guarantee issued by ICICI Bank Limited ("ICICI Bank") favoring yourself on behalf of: INDIGRID 2 LIMITED, UNIT,NO 101, 1 FLOOR WINDSOR,,VILLAGE,, KOLE KAL,ARG SANTACRUZ EAST,MUMBAI MAHARASH,, YAN OFF CST ROAD VIDYANAGARI M, MUMBAI, MAHARASHTRA, INDIA, 400098 ("Bank Guarantee") with the tenor and claim period as requested by you. For ease of reference the details have been reproduced as below:

Bank Guarantee No. & Date of Issue	Expiry Date	Claim Expiry Date	Currency	Amount of Bank Guarantee
0555NDLG00000925 04-04-2024	31-01-2026	31-01-2027	INR	3,00,00,000.00

We confirm that the officials who have signed the above Bank Guarantee are authorized to sign such documents on behalf of ICICI Bank. You may verify genuineness of the Bank Guarantee by writing to us at bgconfirmation@icicibank.com for receiving the confirmation over email.

Alternatively, you may also write to the following address to verify the genuineness of the BG :

ICICI Bank Limited, Trade Finance Operations Group,
ICICI Bank Towers, Survey No.115/27, Tower 3, South Wing, 6th Floor,
Plot No. 12, Nanakramguda, Serilingampally, Hyderabad - 500032, Telangana

In the event of invocation, we request you to please ensure compliance with the terms and conditions of the Bank Guarantee in order to ensure timely payment. You are requested to ensure special care inter alia with respect to the following in the invocation claim letter -

- Bank Guarantee Number
- Expiry/Claim Expiry date
- Claim Amount
- Designated Bank branch for submission of invocation claim
- Any declaration / certification that may be required as part of the guarantee text.
- Any other requisite document including the original Bank Guarantee.

Please note that ICICI Bank shall not be liable under the Bank Guarantee post expiry of the claim period as requested by you.

Thanking you,

Yours faithfully,

For ICICI Bank Limited
Authorized Signatory

MINU MINAXI
Deputy Manager-II 407508

ICICI Bank Limited
9A, Phelps Building, 2nd Floor,
Connaught Place,
New Delhi - 110 001,
Delhi, India.

Website www.icicibank.com
CIN :L65190GJ1994PLC021012

Regd. Office : ICICI Bank Tower, Near Chakli Circle,
Old Padra Road, Vadodara 390 007,
India.
Corp. Office : ICICI Bank Towers, Bandra-Kurla
Complex, Mumbai 400051, India.



सत्यमेव जयते

Government of National Capital Territory of Delhi

₹100

e-Stamp

Certificate No.	: IN-DL68755818989797W
Certificate Issued Date	: 03-Apr-2024 08:31 AM
Account Reference	: IMPACC (IV)/ dl736003/ DELHI/ DL-DLH
Unique Doc. Reference	: SUBIN-DL73600396499647442634W
Purchased by	: ICICI BANK
Description of Document	: Article Bank Guarantee
Property Description	: Not Applicable
Consideration Price (Rs.)	: 0 (Zero)
First Party	: ICICI BANK
Second Party	: Not Applicable
Stamp Duty Paid By	: ICICI BANK
Stamp Duty Amount(Rs.)	: 100 (One Hundred only)

सत्यमेव जयते



₹100

Please write or type below this line

IN-DL68755818989797W

This Stamp Paper forms an Integral Part of

BG No. 0555NDL600000925Dated 4.4.2024Amount ₹ 30000000.00

For ICICI Bank Limited
Deepali
 Authorised Signatory
 Transaction Banking, SA, C.P., N.D.-1

DEEPALI GUPTA
 Deputy Manager-II : 453822

RUCHITA SINGH
 Manager-I, S-13827

Statutory Alert:

1. The authenticity of this Stamp certificate should be verified at 'www.shoilestamp.com' or using e-Stamp Mobile App of Stock Holding. Any discrepancy in the details on this Certificate and as available on the website / Mobile App renders it invalid.
2. The onus of checking the legitimacy is on the users of the certificate.
3. In case of any discrepancy please inform the Competent Authority

BANK GUARANTEE**ICICI Bank Limited**

(Incorporated in India)

1 **CONTRACT PERFORMANCE GUARANTEE**

2 In consideration of the IndiGrid 2 Limited, Unit No. 101, First Floor, Windsor Village,
 3 KoleKalyan Santacruz (East), Off CST Road, Vidyanagri Marg, Mumbai Maharashtra-400098,
 4 (INDIA) [Insert name of the SPV or Selected Bidder on behalf of SPV or Lead Member in case
 5 of the Consortium, with address] agreeing to undertake the obligations under the
 6 Transmission Service Agreement to be executed on dated 05th April 2024 and the other RFP
 7 Project Documents and the Nodal Agency and REC Power Development and Consultancy
 8 Limited [Name of BPC], agreeing to execute the RFP Project Documents with the Selected
 9 Bidder, regarding setting up the Project, We ICICI Bank Ltd, a schedule bank in India
 10 incorporated under the Provisions of the companies Act, 1956 and having its registered office
 11 at ICICI Bank Tower, Near Chakli Circle, Old Padra Road, Vadodara-390007, India and having
 12 a branch office at ICICI Bank Ltd, ICICI Bank Towers, Bandra Kurla Complex, Bandra (East),
 13 Mumbai Maharashtra-400051 (hereinafter referred to as "Guarantor Bank") hereby agrees
 14 unequivocally, irrevocably and unconditionally to pay to Central Transmission Utility of India
 15 Limited (being the Nodal Agency) at "Saudamini" First Floor, Plot No. 2, Sector-29, Gurugram,
 16 Haryana-122001 [Insert Place and Address of the Nodal Agency indicated in TSA] forthwith
 17 on demand in writing from the Nodal Agency or any Officer authorized by it in this behalf, any
 18 amount up to and not exceeding Rs.3,00,00,000.00 (Three Crore Rupees only) on behalf of
 19 M/s. IndiGrid 2 Limited [Insert name of the Selected Bidder / SPV].

20 This guarantee shall be valid and binding on the Guarantor Bank up to and including 31st
 21 January 2026 and shall not be terminable by notice or any change in the constitution of the
 22 Bank or the term of the Transmission Service Agreement or by any other reasons whatsoever
 23 and our liability hereunder shall not be impaired or discharged by any extension of time or
 24 variations or alternations made, given, or agreed with or without our knowledge or consent,
 25 by or between parties to the respective agreement.

26 Our liability under this Guarantee is restricted to Rs.3,00,00,000.00 (Three Crore Rupees only).
 27 Our Guarantee shall remain in force until 31st January 2026 [Insert the date of validity of the
 28 Guarantee as per Clause 2.12.1 of the RFP]. The Nodal Agency shall be entitled to invoke this
 29 Guarantee up to three hundred sixty five (365) days of the last date of the validity of this
 30 Guarantee.

31 The Guarantor Bank hereby expressly agrees that it shall not require any proof in addition to
 32 the written demand from Central Transmission Utility of India Limited (in its roles as Nodal
 33 Agency), made in any format, raised at the above mentioned address of the Guarantor Bank,

Page 1 of 3

For ICICI Bank Limited

Deepali

Authorised Signatory
Transaction Banking, SA, C.P., N.D.-1**DEEPALI GUPTA**

Deputy Manager-II : 453822

RUCHITA SINGH
Manager-I, S-13827

The beneficiary may, in its own interest, verify the genuineness of the bank guarantee by seeking confirmation of its issuance by writing to the email ID bgconfirmation@icicibank.com or to ICICI Bank Limited, Trade Finance Operations Group, ICICI Bank Towers, Survey No.115/27, Tower 3, South Wing, 6th Floor, Plot No. 12, Nanakramguda, Serilingampally, Hyderabad – 500032, Telangana.

Regd. Office: ICICI Bank Ltd., ICICI Bank Tower, Near Chakli Circle, Old Padra Road, Vadodara, Pin code- 390 007, Gujarat
 Phone : +91-265-6722286, CIN L65190GJ1994PLC021012

BANK GUARANTEE
ICICI Bank Limited

(Incorporated in India)



In order to make the said payment to the Nodal Agency.

- 35 The Guarantor Bank shall make payment hereunder on first demand without restriction or
36 conditions and notwithstanding any objection by IndiGrid 2 Limited, Kallam Transco Limited
37 and/or any other person. The Guarantor Bank shall not require the Nodal Agency to justify the
38 invocation of this BANK GUARANTEE, nor shall the Guarantor Bank have any recourse
39 against the Nodal Agency in respect of any payment made hereunder.
- 40 This BANK GUARANTEE shall be interpreted in accordance with the laws of India.
- 41 The Guarantor Bank represents that this BANK GUARANTEE has been established in such
42 form and with such content that it is fully enforceable in accordance with its terms as against
43 the Guarantor Bank in the manner provided herein.
- 44 This BANK GUARANTEE shall not be affected in any manner by reason of merger,
45 amalgamation, restructuring, liquidation, winding up, dissolution or any other change in the
46 constitution of the Guarantor Bank.
- 47 This BANK GUARANTEE shall be a primary obligation of the Guarantor Bank and accordingly
48 the Nodal Agency shall not be obliged before enforcing this BANK GUARANTEE to take any
49 action in any court or arbitral proceedings against Kallam Transco Limited [Name of SPV] or
50 the Selected Bidder as the case may be, to make any claim against or any demand on Kallam
51 Transco Limited [Name of SPV] or the Selected Bidder, as the case may be, or to give any
52 notice to Kallam Transco Limited [Name of SPV] or the Selected Bidder, as the case may be, or
53 to enforce any security held by the Nodal Agency or to exercise, levy or enforce any distress,
54 diligence or other process against Kallam Transco Limited [Name of SPV] or the Selected
55 Bidder, as the case may be.
- 56 The Guarantor Bank acknowledges that this BANK GUARANTEE is not personal to the Nodal
57 Agency and may be assigned, in whole or in part, (whether absolutely or by way of security)
58 by Nodal Agency to any entity to whom the Nodal Agency is entitled to assign its rights and
59 obligations under the Transmission Service Agreement.
- 60 The Guarantor Bank hereby agrees and acknowledges that the Nodal Agency shall have a
61 right to invoke this Bank Guarantee either in part or in full, as it may deem fit.
- 62 Notwithstanding anything contained hereinabove, our liability under this Guarantee is
63 restricted to Rs.3,00,00,000.00 (Three Crore Rupees only) and it shall remain in force until 31st

Page 2 of 3

DEEPALI GUPTA
Deputy Manager-II : 453822**For ICICI Bank Limited**
Deepali
Authorized Signatory
Transaction Banking, SA, C.P., N.D.-1**RUCHITA SINGH,**
Manager-I, S-13827

The beneficiary may, in its own interest, verify the genuineness of the bank guarantee by seeking confirmation of its issuance by writing to the email ID bgconfirmation@icicibank.com or to ICICI Bank Limited, Trade Finance Operations Group, ICICI Bank Towers, Survey No.115/27, Tower 3, South Wing, 6th Floor, Plot No. 12, Nanakramguda, Serilingampally, Hyderabad - 500032, Telangana.

Regd. Office: ICICI Bank Ltd., ICICI Bank Tower, Near Chakli Circle, Old Padra Road, Vadodara, Pin code- 390 007, Gujarat
Phone : +91-265-6722286, CIN L65190GJ1994PLC021012

BANK GUARANTEE**ICICI Bank Limited**

(Incorporated in India) 64 January 2026 [Date to be inserted on the basis of Article 3.1.2 of TSA], with an additional
65 claim period of three hundred sixty five (365) days thereafter.

66 This BANK GUARANTEE shall be extended from time to time for such period, as may be
67 desired by IndiGrid 2 Limited [Insert name of the Selected Bidder or Lead Member in case of
68 the Consortium or SPV]. We are liable to pay the guaranteed amount or any part thereof
69 under this Bank Guarantee only if the Nodal Agency serves upon us a written claim or
70 demand at ICICI Bank Ltd, 9A, Phelps Building, Inner Circle, Connaught Place, New Delhi
71 110001.

72 The liability of the Guarantor under this Guarantee shall not exceed Rs.3,00,00,000.00 (Three
73 Crore Rupees only) (the "Guaranteed Amounts").

74 This Guarantee shall be valid up to 31/01/2026 (the "Expiry Date").

75 Notwithstanding anything to the contrary contained herein, no obligation of the Guarantor to
76 pay any amount under this Guarantee shall arise prior to the fulfillment of the following
77 conditions precedent:

78 (a) written claim/demand(s) in terms of this Guarantee of an aggregate amount less than or
79 equal to the Guaranteed Amounts is/are made by the Beneficiary hereunder; and

80 (b) such written claim/demand(s) is/are delivered to the Guarantor on or before the
81 31/01/2027 at the ICICI Bank branch located at ICICI Bank Ltd, 9A, Phelps Building, Inner
82 Circle, Connaught Place, New Delhi 110001.

83 Date: 04/04/2024

84 Place: Delhi

85 FOR ICICI BANK LIMITED

86 Authorised Signatories

87 Signature: _____ Signature: _____

88 Name: Deepali **For ICICI Bank Limited** Name: Ruchita **For ICICI Bank Limited**

89 Signature Code: Deepali **Authorized Signatory** Signature Code: Ruchita **Authorized Signatory**
Transaction Banking, 9A, C.P., N.D.-1

DEEPALI GUPTA
Deputy Manager-II : 453822

Page 3 of 3

RUCHITA SINGH,
Manager-I, S-13827

The beneficiary may, in its own interest, verify the genuineness of the bank guarantee by seeking confirmation of its issuance by writing to the email ID bgconfirmation@icicibank.com or to ICICI Bank Limited, Trade Finance Operations Group, ICICI Bank Towers, Survey No.115/27, Tower 3, South Wing, 6th Floor, Plot No. 12, Nanakramguda, Serilingampally, Hyderabad – 500032, Telangana.

Regd. Office: ICICI Bank Ltd., ICICI Bank Tower, Near Chakli Circle, Old Padra Road, Vadodara, Pin code- 390 007, Gujarat
Phone : +91-265-6722286, CIN L65190GJ1994PLC021012

From: Wasim Alam
To: TBCB Projects
Cc: P S Hariharan; RECPDCL Satyabhan Sahoo Sir; Ankit Kumar; Anil Kumar Perala; Ritam Biswas; RECPDCL Fin Department; CS Division RECPDCL; Aditya Kislai; Puneet Singh Chauhan; Shivam Pathak; Rajnish Mishra; Ramil Gupta; Ganesh Dutt
Subject: RE: RECPDCL: Final Acquisition Price of Kallam Transco Limited and SPV Transfer -Regarding.
Date: 05 April 2024 11:45:56
Attachments: image001.png
image002.png
image003.png

General

Dear Sir,

Please find UTR details for transferring the SPV Acquisition Price of Kallam Transco Limited;

Transaction Date	Description	Amount (INR)
05/04/2024	RTGS/ICICR42024040500506492/IDFB0020101/	4,52,64,465.40 DR
Transaction Date	Description	Amount (INR)
05/04/2024	RTGS/ICICR42024040500506493/IDFB0020101/	1,93,99,056.60 DR

This is for your kind information.

Kindly acknowledge the receipt of the same.

Thanks & Regards,
Wasim Alam
Senior Manager - Bidding & Business Development



IndiGrid Limited
10th Floor, Berger Tower
Delhi One Complex, Sector-16 B
Noida, Uttar Pradesh-201301 (INDIA)
Email : wasim.alam1@indigrid.com
Mob : +91-9205620636

From: TBCB Projects <tbcb@recpdcl.in>
Sent: Thursday, April 4, 2024 3:23 PM
To: Wasim Alam <wasim.alam1@indigrid.com>; Aditya Kislai <aditya.kislai@indigrid.com>; Puneet Singh Chauhan <puneet.chauhan@indigrid.com>; Shivam Pathak <shivam.pathak@indigrid.com>
Cc: Deepak Krishnan (दीपक कृष्णन) <deepakkrishnan@powergrid.in>; P S Hariharan <pshariharan@recpdcl.in>; RECPDCL Satyabhan Sahoo Sir <satyabhan.sahoo@recpdcl.in>; Ankit Kumar <ankit.kumar@recpdcl.in>; Anil Kumar Perala <anilkperala@recpdcl.in>; Ritam Biswas <ritam.biswas@recpdcl.in>; RECPDCL Fin Department <fin.delhi@recpdcl.in>; CS Division RECPDCL <cs@recpdcl.in>
Subject: Re: RECPDCL: Final Acquisition Price of Kallam Transco Limited and SPV Transfer -Regarding.

[Mail from External Sender - be careful with Links, Attachments and Responses.](#)

Dear Sir,

In continuation to the trailing mail, this is to inform that the date of transfer of SPV of Kallam Transco Limited is scheduled on 05.04.2024, (Friday) 11:00 am at REC Headquarter, Gurugram.
You are requested to kindly attend the same.

Thanks & Regards,
Jitendra Singh,
TBCB Division, RECPDCL

On Tue, Apr 2, 2024 at 1:25 PM Wasim Alam <wasim.alam1@indigrid.com> wrote:

General

Dear Sir,

Please find enclosed herewith **copy of BR (Authorised Signatory) for signing the SPA & TSA of Kallam Transco Limited.**

This is for your kind information.

Thanks & Regards,

Wasim Alam

Senior Manager - Bidding & Business Development



IndiGrid Limited

10th Floor, Berger Tower

Delhi One Complex, Sector-16 B

Noida, Uttar Pradesh-201301 (INDIA)

Email : wasim.alam1@indigrid.com

Mob : +91-9205620636

From: TBCB Projects <tcb@repcdcl.in>

Sent: Wednesday, March 27, 2024 7:05 PM

To: Wasim Alam <wasim.alam1@indigrid.com>; Aditya Kislay <aditya.kislay@indigrid.com>; Puneet Singh Chauhan <puneet.chauhan@indigrid.com>

Cc: Deepak Krishnan (दीपक कृष्णन) <deepakkrishnan@powergrid.in>; P S Hariharan <pshariharan@repcdcl.in>; RECPDCL Satyabhan Sahoo Sir <satyabhan.sahoo@repcdcl.in>; Ankit Kumar <ankit.kumar@repcdcl.in>; Anil Kumar Perala <anilkperala@repcdcl.in>; Ritam Biswas <ritam.biswas@repcdcl.in>; AMIT CHATTERJEE <amitchatterjee141985@gmail.com>

Subject: RECPDCL: Final Acquisition Price of Kallam Transco Limited and SPV Transfer -Regarding.

Mail from External Sender - be careful with Links, Attachments and Responses.

Sir,

Please find enclosed our office letter dated 27.03.2024 in respect of Final Acquisition Price of Kallam Transco Limited. The date of transfer of subject SPV shall be 05.04.2024.

In respect of CPG & TSA finalization and execution, please contact Mr. Deepak Krishnan, Manager(Technical), CTUIL under intimation to us.

Thanks & Regards

Kshitiz Arora

TBCB Division

RECPDCL



::DISCLAIMER::

The contents of this e-mail and any attachment(s) with it are confidential and intended for the sole use of named recipients and may contain legally confidential and / or privileged information. It shall not attach any liability on the originator. Any views or opinions presented in this email are solely those of the author and may not necessarily reflect the opinions of RECPDCL or its subsidiaries. If the reader of this message is not the intended recipient, immediately inform the originator by reply e-mail and delete this mail will all content and attachment(s) . Any unauthorized reproduction, dissemination, copying, disclosure, modification, distribution and / or publication of this e-mail and attachment is strictly prohibited and may be unlawful. Before opening any mail and attachments please check them for viruses and defect. Email communications are not secure and capable of interception corruption and delays. Anyone communicating with the originator or RECPDCL or its subsidiaries by email accept the risk of email communication and their consequences.

Disclaimer: The contents of this e-mail message and any attachments are confidential and are intended solely for the addressee. If you have received this transmission in error, please immediately notify the sender by return e-mail and delete this message and its attachments. Any unauthorized use, copying or dissemination of this transmission is prohibited. Neither the confidentiality nor the integrity of this message can be vouched for following transmission on the Internet.



::DISCLAIMER::

The contents of this e-mail and any attachment(s) with it are confidential and intended for the sole use of named recipients and may contain legally confidential and / or privileged information. It shall not attach any liability on the originator. Any views or opinions presented in this email are solely those of the author and may not necessarily reflect the opinions of RECPDCL or its subsidiaries. If the reader of this message is not the intended recipient, immediately inform the originator by reply e-mail and delete this mail will all content and attachment(s) . Any unauthorized reproduction, dissemination, copying, disclosure, modification, distribution and / or publication of this e-mail and attachment is strictly prohibited and may be unlawful. Before

opening any mail and attachments please check them for viruses and defect. Email communications are not secure and capable of interception corruption and delays. Anyone communicating with the originator or RECPDCL or its subsidiaries by email accept the risk of email communication and their consequences.

TRANSMISSION SERVICE AGREEMENT

FOR

**DEVELOPMENT AND OPERATION OF INTER-
STATE TRANSMISSION SYSTEM**

**FOR TRANSMISSION OF ELECTRICITY
THROUGH TARIFF BASED COMPETITIVE
BIDDING FOR**

**WESTERN REGION NETWORK EXPANSION
SCHEME IN KALLAM AREA OF MAHARASHTRA**

BETWEEN THE

**CENTRAL TRANSMISSION UTILITY OF INDIA
LIMITED**

(NODAL AGENCY)

AND

KALLAM TRANSCO LIMITED

April...05..., 2024



CONTENTS

1	Definitions and Interpretations.....	6
2	Effectiveness and Term of Agreement.....	18
3	Conditions Subsequent.....	20
4	Development of the Project.....	25
5	Construction of the Project.....	30
6	Connection and commissioning of the Project.....	35
7	Operation and Maintenance of the Project.....	40
8	Availability of the project.....	41
9	Insurances.....	42
10	Billing And Payment of Transmission Charges.....	44
11	Force Majeure.....	45
12	Change in Law.....	50
13	Events of Default and Termination.....	53
14	Liability and Indemnification.....	58
15	Assignments and Charges.....	64
16	Governing Law and Dispute Resolution.....	66
17	Representation and Warranties.....	68
18	Independent Engineer.....	70
19	Miscellaneous Provisions.....	72



Transmission Service Agreement		Indian-Non Judicial Stamp		Haryana Government		Date :18/03/2024	
Bond							
Certificate No. G0R2024C3841				Stamp Duty Paid : ₹ 101 (Rs. Only)			
GRN No. 114048854				Penalty : ₹ 0 (Rs. Zero Only)			
Deponent							
Name: Central Transmission utility of India Ltd							
H.No/Floor : 2		Sector/Ward : 29		Landmark : Na			
City/Village : Gurugram		District : Gurugram		State : Haryana			
Phone : 98*****10							
Purpose : ARTICLE 5 GENERAL AGREEMENT to be submitted at Concerned office							

THIS TRANSMISISON SERVICE AGREEMENT (hereinafter referred to as "TSA" or "Agreement" or "the Agreement" or "this Agreement") is made on the ...05th [Insert day] of April..... [Insert month] of Two Thousand and...2024..... [Insert Year]

BETWEEN:

The **Central Transmission Utility of India Limited**, "Saudamini", 1st Floor, Plot No. 2, Sector-29, Gurugram-122001, Haryana acting as a Nodal Agency (referred to as the "Nodal Agency"), which expression shall unless repugnant to the context or meaning thereof include its successors, and permitted assigns) as Party of the one part;

AND

Kallam Transco Limited incorporated under the Companies Act, 2013, having its registered office at Core-4, Scope Complex 7, Lodhi Road Delhi, South Delhi, Delhi 110003 (herein after referred to as "Transmission Service Provider" or "TSP" or "ISTS Licensee", which expression shall unless repugnant to the context or meaning thereof include its successors, and permitted assigns) as Party of the other part;

Central Transmission Utility of India Limited

3

Kallam Transco Limited
1 April 2024

(“Nodal Agency” and “TSP” are individually referred to as “Party” and collectively as the “Parties”)

AND WHEREAS:

- A) In accordance with the Bidding Guidelines, the Bid Process Coordinator (hereinafter referred to as BPC) had initiated a competitive e-reverse bidding process through issue of RFP for selecting a Successful Bidder to build, own, operate and transfer the Project comprising of the Elements mentioned in Schedule 1 (hereinafter referred to as the Project)
- B) Pursuant to the said e-reverse bidding process, the BPC has identified the Successful Bidder, who will be responsible to set up the Project on build, own, operate and transfer basis to provide Transmission Service in accordance with the terms of this Agreement and the Transmission License.
- C) The Selected Bidder have submitted the Contract Performance Guarantee and acquired one hundred percent (100%) of the equity shareholding of Kallam Transco Limited, along with all its related assets and liabilities in terms of the provisions of the Share Purchase Agreement.
- D) The TSP has agreed to make an application for a Transmission License to the Commission for setting up the Project on build, own, operate and transfer basis.
- E) The TSP has further agreed to make an application to the Commission for the adoption of the Transmission Charges under Section 63 of the Electricity Act, 2003, along with a certification from the Bid Evaluation Committee in accordance with the Bidding Guidelines issued by Ministry of Power, Government of India.
- F) The TSP has agreed to execute the agreement(s) required, if any, under Sharing Regulations within fifteen (15) days from the date of grant of Transmission License from the Commission.
- G) The TSP agrees to the terms and conditions laid down under Sharing Regulations, for making available the ISTS and charge the Transmission Charges in accordance with the terms and conditions of Sharing Regulations.
- H) The billing, collection and disbursement of the Transmission Charges by the CTU to the ISTS Licensee shall be governed as per Sharing Regulations.

- l) The terms and conditions stipulated in the Transmission License issued by the Commission to the TSP shall be applicable to this Agreement and the TSP agrees to comply with these terms and conditions. In case of inconsistency between the Transmission License terms & conditions and the conditions of this Agreement, the conditions stipulated in the Transmission License granted by the Commission shall prevail.

NOW, THEREFORE, IN CONSIDERATION OF THE PREMISES AND MUTUAL AGREEMENTS, COVENANTS AND CONDITIONS SET FORTH HEREIN, IT IS HEREBY AGREED BY AND BETWEEN THE PARTIES HERETO AS FOLLOWS:



Central Transmission Utility of India Limited

5



Kallam Transco Limited

1 April 2024

ARTICLE: 1**1 DEFINITIONS AND INTERPRETATIONS****1.1 Definitions:**

1.1.1 The words / expressions used in this Agreement, unless as defined below or repugnant to the context, shall have the same meaning as assigned to them by the Electricity Act, 2003 and the rules or regulations framed there under including those issued / framed by the Commission (as defined hereunder), as amended or re-enacted from time to time or the General Clauses Act, failing which it shall bear its ordinary English meaning.

The words/expressions when used in this Agreement shall have the respective meanings as specified below:

“Acquisition Price” shall have the same meaning as defined in the Share Purchase Agreement;

“Act” or **“Electricity Act”** or **“Electricity Act 2003”** shall mean the Electricity Act, 2003 and any amendments made to the same or any succeeding enactment thereof;

“Affiliate” shall mean a company that either directly or indirectly

- i. controls or
- ii. is controlled by or
- iii. is under common control with

a Bidding Company (in the case of a single company) or a Member (in the case of a Consortium) and **“control”** means ownership by one entity of at least twenty-six percent (26%) of the voting rights of the other entity;

“Availability” in relation to the Project or in relation to any Element of the Project, for a given period shall mean the time in hours during that period the Project is capable to transmit electricity at its Rated Voltage and shall be expressed in percentage of total hours in the given period and shall be calculated as per the procedure contained in Appendix –II to Central Electricity Regulatory Commission (Terms and Conditions of Tariff) Regulations, 2019, attached herewith in Schedule 6;

“Bid” shall mean technical bid and financial bid submitted by the Bidder, in response to the RFP, in accordance with the terms and conditions of the RFP.

“**Bid Deadline**” shall mean the last date and time for submission of the Bid in response to RFP, as specified in the RFP;

“**Bidding Company**” shall refer to such single company that has made a Response to RFP for the Project;

“**Bidding Consortium / Consortium**” shall refer to a group of companies that has collectively made a Response to RFP for the Project;

“**Bid Documents**” or “**Bidding Documents**” shall mean the RFP, along with all attachments thereto or clarifications thereof;

“**Bidding Guidelines**” shall mean the “Tariff Based Competitive Bidding Guidelines for Transmission Service” and “Guidelines for Encouraging Competition in Development of Transmission Projects” issued by Government of India, Ministry of Power under Section – 63 of the Electricity Act as amended from time to time;

“**Bid Process Coordinator**” or “**BPC**” shall mean a person or its authorized representative as notified by the Government of India, responsible for carrying out the process for selection of Bidder who will acquire Transmission Service Provider;

“**Bill**” shall mean any bill raised by the CTU on the DICs to recover the Transmission Charges pursuant to the Sharing Regulations;

“**Business Day**” shall mean a day other than Sunday or a statutory holiday, on which the banks remain open for business in the State in which the Nodal Agency’s registered office is located and the concerned TSP are located;

“**CEA**” shall mean the Central Electricity Authority constituted under Section -70 of the Electricity Act;

“**Change in law**” shall have the meaning ascribed thereto in Article 12;

“**Commercial Operation Date**” or “**COD**” shall mean the date as per Article 6.2;

“**Commission**” or “**CERC**” shall mean the Central Electricity Regulatory Commission referred to in sub-section (1) of Section 76 of the Electricity Act, 2003 or its successors and assigns;

“**Competent Court of Law**” shall mean the Supreme Court or any High Court, or any tribunal or any similar judicial or quasi-judicial body in India that has jurisdiction to adjudicate upon issues relating to the Project;

“**Connection Agreement**” shall mean the agreement between the CTU or STU or any other concerned parties and the TSP, setting out the terms relating to the connection of the Project to the Inter-Connection Facilities and use of the Inter State Transmission System as per the provisions of the IEGC, as the case may be;

“**Consultation Period**” shall mean the period of sixty (60) days or such longer period as the Parties may agree, commencing from the date of issue of a TSP’s Preliminary Notice or a Nodal Agency’s Preliminary Termination Notice, as provided in Article 13 of this Agreement, for consultation between the Parties to mitigate the consequence of the relevant event having regard to all the circumstances;

“**Consents, Clearances and Permits**” shall mean all authorizations, licenses, approvals, registrations, permits, waivers, privileges, acknowledgements, agreements, or concessions required to be obtained from or provided by any concerned authority for the development, execution and operation of Project including without any limitation for the construction, ownership, operation and maintenance of the Transmission Lines and/or sub-stations;

“**Construction Period**” shall mean the period from (and including) the Effective Date of the Transmission Service Agreement up to (but not including) the COD of the Element of the Project in relation to an Element and up to (but not including) the COD of the Project in relation to the Project;

“**Contractors**” shall mean the engineering, procurement, construction, operation & maintenance contractors, surveyors, advisors, consultants, designers, suppliers to the TSP and each of their respective sub-contractors (and each of their respective successors and permitted assigns) in their respective capacities as such;

“**Contract Performance Guarantee**” shall mean the irrevocable unconditional bank guarantee, submitted and to be submitted by the TSP or by the Selected Bidder on behalf of the TSP to the Nodal Agency from a bank mentioned in Annexure 17 of the RFP, in the form attached here to as Schedule 8, in accordance with Article 3 of this Agreement and which shall include the additional bank guarantee furnished by the TSP under this Agreement;

“**Contract Year**”, for the purpose of payment of Transmission Charges, shall mean the period beginning on the COD, and ending on the immediately succeeding March 31 and thereafter each period of 12



months beginning on April 1 and ending on March 31 provided that the last Contract Year shall end on the last day of the term of the TSA;

“**CTU**” or “**Central Transmission Utility**” shall have same meaning as defined in the Electricity Act, 2003;

“**Day**” shall mean a day starting at 0000 hours and ending at 2400 hours;

“**D/C**” shall mean Double Circuit;

“**Designated ISTS Customers**” or “**DICs**” shall have the meaning as ascribed in the Sharing Regulations;

“**Dispute**” shall mean any dispute or difference of any kind between the Parties, in connection with or arising out of this Agreement including any issue on the interpretation and scope of the terms of this Agreement as provided in Article 16;

“**Effective Date**” for the purposes of this Agreement, shall have the same meaning as per Article 2.1 of this Agreement;

“**Electrical Inspector**” shall mean a person appointed as such by the Government under sub-section (1) of Section 162 of the Electricity Act 2003 and also includes Chief Electrical Inspector;

“**Electricity Rules 2005**” shall mean the rules framed pursuant to the Electricity Act 2003 and as amended from time to time;

“**Element**” shall mean each Transmission Line or each circuit of the Transmission Lines (where there are more than one circuit) or each bay of Sub-station or switching station or HVDC terminal or inverter station of the Project, including ICTs, Reactors, SVC, FSC, etc. forming part of the ISTS, which will be owned, operated and maintained by the concerned ISTS Licensee, and which has a separate Scheduled COD as per Schedule 2 of this Agreement and has a separate percentage for recovery of Transmission Charges on achieving COD as per Schedule 5 of this Agreement;

“**Event of Default**” shall mean the events as defined in Article 13 of this Agreement;

“**Expiry Date**” shall be the date which is thirty-five (35) years from the COD of the Project;

“**Financial Closure**” shall mean the first Business Day on which funds are made available to the TSP pursuant to the Financing Agreements;



“Financially Evaluated Entity” shall mean the company which has been evaluated for the satisfaction of the financial requirement set forth in the RFP;

“Financing Agreements” shall mean the agreements pursuant to which the TSP is to finance the Project including the loan agreements, security documents, notes, indentures, security agreements, letters of credit and other documents, as may be amended, modified, or replaced from time to time, but without in anyway increasing the liabilities of the Designated ISTS Customers / Nodal Agency;

“Financial Year” shall mean a period of twelve months at midnight Indian Standard Time (IST) between 1st April & 31st March;

“Force Majeure” and **“Force Majeure Event”** shall have the meaning assigned thereto in Article 11;

“GOI” shall mean Government of India;

“Grid Code” / “IEGC” shall mean the Grid Code specified by the Central Commission under Clause (h) of sub-section (1) of Section 79 of the Electricity Act;

“Independent Engineer” shall mean an agency/ company, appointed by Nodal Agency in accordance with the Guidelines for Encouraging Competition in Development of Transmission Projects.

“Indian Governmental Instrumentality” shall mean Government of India, Government of any State in India or any ministry, department, board, authority, agency, corporation, commission under the direct or indirect control of Government of India or any State Government or both, any political sub-division of any of them including any court or Commission or tribunal or judicial or quasi-judicial body in India but excluding the CTU, TSP and the Designated ISTS Customers;

“Insurances” shall mean the insurance cover to be obtained and maintained by the TSP in accordance with Article 9 of this Agreement;

“Interconnection Facilities” shall mean the facilities as may be set up for transmission of electricity through the use of the Project, on either one or both side of generating station's / CTU's / STU's / ISTS Licensee's / Designated ISTS Customer's substations (as the case may be) which shall include, without limitation, all other transmission lines, gantries, substations and associated equipments not forming part of the Project;



“ISTS Licensee” shall be the TSP under this Agreement, consequent to having been awarded a Transmission License by the CERC and shall be referred to as the TSP or the ISTS Licensee, as the context may require in this Agreement;

“Law” or “Laws” in relation to this Agreement, shall mean all laws including electricity laws in force in India and any statute, ordinance, rule, regulation, notification, order or code, or any interpretation of any of them by an Indian Governmental Instrumentality having force of law and shall include all rules, regulations, decisions and orders of the Commission;

“Lead Member of the Bidding Consortium” or “Lead Member” shall mean a company who commits at least 26% equity stake in the Project, meets the technical requirement as specified in the RFP and so designated by other Member(s) in Bidding Consortium;

“Lenders” means the banks, financial institutions, multilateral funding agencies, non-banking financial companies registered with the Reserve Bank of India (RBI), insurance companies registered with the Insurance Regulatory & Development Authority (IRDA), pension funds regulated by the Pension Fund Regulatory & Development Authority (PFRDA), mutual funds registered with Securities & Exchange Board of India (SEBI), etc., including their successors and assigns, who have agreed on or before COD of the Project to provide the TSP with the debt financing described in the capital structure schedule, and any successor banks or financial institutions to whom their interests under the Financing Agreements may be transferred or assigned;

Provided that, such assignment or transfer shall not relieve the TSP of its obligations to the Nodal Agency under this Agreement in any manner and shall also does not lead to an increase in the liability of the Nodal Agency;

“Lenders Representative” shall mean the person notified by the Lender(s) in writing as being the representative of the Lender(s) or the Security Trustee and such person may from time to time be replaced by the Lender(s) pursuant to the Financing Agreements by written notice to the TSP;

“Letter of Intent” or “LOI” shall have the same meaning as in the RFP;

“Member in a Bidding Consortium / Member” shall mean each company in the Bidding Consortium;

“Month” shall mean a period of thirty (30) days from (and excluding) the date of the event;



“Monthly Transmission Charges” for any Element of the Project, after COD of the Element till COD of the Project, and for the Project after COD of the Project, shall mean the amount of Transmission Charges as specified in Schedule 5 of this Agreement multiplied by no. of days in the relevant month and divided by no. of days in the year;

“National Load Despatch Centre” shall mean the centre established as per sub-section (1) of Section 26 of the Electricity Act 2003;

“Nodal Agency” shall mean CTU, which shall execute and implement the Transmission Service Agreement (TSA);

Provided that while taking major decisions, CTU shall consult CEA on technical matters and any other matter it feels necessary.

“Notification” shall mean any notification, issued in the Gazette of India;

“Operating Period” for any Element of the Project shall mean the period from (and including) the COD of such Element of the Project, up to (and including) the Expiry Date and for the Project, shall mean the period from (and including) the COD of the Project, up to (and including) the Expiry Date;

“Parent Company” shall mean an entity that holds at least twenty-six percent (26%) of the paid - up equity capital directly or indirectly in the Bidding Company or in the Member in a Bidding Consortium, as the case may be;

“Preliminary Termination Notice” shall mean a Nodal Agency's Preliminary Termination Notice as defined in Article 13 of this Agreement;

“Project” shall mean Western Region Network Expansion scheme in Kallam area of Maharashtra, as detailed in Schedule 1 of this Agreement;

“Project Assets” shall mean all physical and other assets relating to and forming part of the Project including:

(a) rights over the Site for substations, ROW for transmission lines;

(b) tangible & intangible assets such as civil works and equipment including foundations, embankments, pavements, electrical systems, communication systems, relief centres, administrative offices, Sub-stations, software, tower and sub-stations designs etc;

(c) project facilities situated on the Site;



- (d) all rights of the TSP under the project agreements;
- (e) financial assets, such as receivables, security deposits etc;
- (f) insurance proceeds; and
- (g) Applicable Permits and authorisations relating to or in respect of the Transmission System;”

“**Project Execution Plan**” shall mean the plan referred to in Article 3.1.3(c) hereof;

“**Prudent Utility Practices**” shall mean the practices, methods and standards that are generally accepted internationally from time to time by electric transmission utilities for the purpose of ensuring the safe, efficient and economic design, construction, commissioning, operation, repair and maintenance of the Project and which practices, methods and standards shall be adjusted as necessary, to take account of:

- (i) operation, repair and maintenance guidelines given by the manufacturers to be incorporated in the Project,
- (ii) the requirements of Law, and
- (iii) the physical conditions at the Site;
- (iv) the safety of operating personnel and human beings;

“**Rated Voltage**” shall mean voltage at which the Transmission System is designed to operate or such lower voltage at which the line is charged, for the time being, in consultation with the Central Transmission Utility;

“**Rebate**” shall have the meaning as ascribed to in Article 10.3 of this Agreement;

“**RFP**” shall mean Request for Proposal dated 13.10.2023 along with all schedules, annexures and RFP Project Documents attached thereto, issued by the BPC for tariff based competitive bidding process for selection of Bidder as TSP to execute the Project, including any modifications, amendments or alterations thereto;

“**RFP Project Documents**” shall mean the following documents to be entered into in respect of the Project, by the Parties to the respective agreements:

- a. Transmission Service Agreement,



- b. Share Purchase Agreement,
- c. Agreement(s) required under Sharing Regulations and
- d. Any other agreement as may be required;

“**RLDC**” shall mean the relevant Regional Load Dispatch Centre as defined in the Electricity Act, 2003, in the region(s) in which the Project is located;

“**RPC**” shall mean the relevant Regional Power Committee established by the Government of India for the specific Region(s) in accordance with the Electricity Act, 2003 for facilitating integrated operation of the Power System in that Region;

“**Scheduled COD**” in relation to an Element(s) shall mean the date(s) as mentioned in Schedule 2 as against such Element(s) and in relation to the Project, shall mean the date as mentioned in Schedule 2 as against such Project, subject to the provisions of Article 4.4 of this Agreement, or such date as may be mutually agreed among the Parties;

“**Scheduled Outage**” shall mean the final outage plan as approved by the RPC as per the provisions of the Grid Code;

“**Selected Bid**” shall mean the technical Bid and the Final Offer of the Selected Bidder submitted during e-reverse bidding, which shall be downloaded and attached in Schedule 7 on or prior to the Effective Date;

“**Share Purchase Agreement**” shall mean the agreement amongst REC Power Development and Consultancy Limited, Kallam Transco Limited and the Successful Bidder for the purchase of one hundred (100%) per cent of the shareholding of the Kallam Transco Limited for the Acquisition Price, by the Successful Bidder on the terms and conditions as contained therein;

“**Sharing Regulations**” shall mean the Central Electricity Regulatory Commission (Sharing of Inter-State Transmission Charges and Losses) Regulations, 2020 and as amended from time to time;

“**Site**” in relation to a substation, switching station or HVDC terminal or inverter station, shall mean the land and other places upon which such station / terminal is to be established;

“**SLDC**” shall mean the State Load Dispatch Centre established as per sub-section (1) of Section 31 of the Electricity Act 2003;



“**STU**” or “**State Transmission Utility**” shall be the Board or the Government company, specified as such by the State Government under sub-section (1) of Section 39 of the Electricity Act 2003;

“**Successful Bidder**” or “**Selected Bidder**” shall mean the Bidder selected pursuant to the RFP and who has to acquire one hundred percent (100%) equity shares of Kallam Transco Limited, along with all its related assets and liabilities, which will be responsible as the TSP to establish the Project on build, own, operate and transfer basis as per the terms of the TSA and other RFP Project Documents;

“**TSP’s Preliminary Notice**” shall mean a notice issued by the TSP in pursuant to the provisions of Article 13.3 of this Agreement;

“**Target Availability**” shall have the meaning as ascribed hereto in Article 8.2 of this Agreement;

“**Technically Evaluated Entity**” shall mean the company which has been evaluated for the satisfaction of the technical requirement set forth in RFP;

“**Termination Notice**” shall mean a Nodal Agency’s Termination Notice given by the Nodal Agency to the TSP pursuant to the provisions of Articles 3.3.2, 3.3.4, 4.4.2, 5.8, 13.2 and 13.3 of this Agreement for the termination of this Agreement;

“**Term of Agreement**” for the purposes of this Agreement shall have the meaning ascribed thereto in Article 2.2 of this Agreement;

“**Transmission Charges**” shall mean the Final Offer of the Selected Bidder during the e-reverse bidding and adopted by the Commission, payable to the TSP as per Sharing Regulations;

“**Transmission License**” shall mean the license granted by the Commission in terms of the relevant regulations for grant of such license issued under the Electricity Act;

“**Transmission Service**” shall mean making the Project available as per the terms and conditions of this Agreement and Sharing Regulations;

“**Unscheduled Outage**” shall mean an interruption resulting in reduction of the Availability of the Element(s) / Project (as the case may be) that is not a result of a Scheduled Outage or a Force Majeure Event.

“**Ultimate Parent Company**” shall mean an entity which owns at least twenty six percent (26%) equity in the Bidding Company or Member of a Consortium, (as the case may be) and in the Technically Evaluated Entity



and / or Financially Evaluated Entity (as the case may be) and such Bidding Company or Member of a Consortium, (as the case may be) and the Technically Evaluated Entity and / or Financially Evaluated Entity (as the case may be) shall be under the direct control or indirectly under the common control of such entity;

1.2 Interpretation:

Save where the contrary is indicated, any reference in this Agreement to:

"Agreement" shall be construed as including a reference to its Schedules, Appendices and Annexures;

"Rupee", "Rupees" and "Rs." shall denote lawful currency of India;

"crore" shall mean a reference to ten million (10,000,000) and a **"lakh"** shall mean a reference to one tenth of a million (1,00,000);

"encumbrance" shall be construed as a reference to a mortgage, charge, pledge, lien or other encumbrance securing any obligation of any person or any other type of preferential arrangement (including, without limitation, title transfer and retention arrangements) having a similar effect;

"holding company" of a company or corporation shall be construed as a reference to any company or corporation of which the other company or corporation is a subsidiary;

"indebtedness" shall be construed so as to include any obligation (whether incurred as principal or surety) for the payment or repayment of money, whether present or future, actual or contingent;

"person" shall have the meaning as defined in Section 2 (49) of the Act;

"subsidiary" of a company or corporation (the holding company) shall be construed as a reference to any company or corporation:

- (i) which is controlled, directly or indirectly, by the holding company, or
- (ii) more than half of the issued share capital of which is beneficially owned, directly or indirectly, by the holding company, or
- (iii) which is a subsidiary of another subsidiary of the holding company,

for these purposes, a company or corporation shall be treated as being controlled by another if that other company or corporation is



able to direct its affairs and/or to control the composition of its board of directors or equivalent body;

"winding-up", "dissolution", "insolvency", or "reorganization" in the context of a company or corporation shall have the same meaning as defined in the Companies Act, 1956/ Companies Act, 2013 (as the case may be).

- 1.2.1 Words importing the singular shall include the plural and vice versa.
- 1.2.2 This Agreement itself or any other agreement or document shall be construed as a reference to this or to such other agreement or document as it may have been, or may from time to time be, amended, varied, novated, replaced or supplemented.
- 1.2.3 A Law shall be construed as a reference to such Law including its amendments or re-enactments from time to time.
- 1.2.4 A time of day shall, save as otherwise provided in any agreement or document be construed as a reference to Indian Standard Time.
- 1.2.5 Different parts of this Agreement are to be taken as mutually explanatory and supplementary to each other and if there is any inconsistency between or among the parts of this Agreement, they shall be interpreted in a harmonious manner so as to give effect to each part.
- 1.2.6 The tables of contents and any headings or sub-headings in this Agreement have been inserted for ease of reference only and shall not affect the interpretation of this Agreement.
- 1.2.7 All interest payable under this Agreement shall accrue from day to day and be calculated on the basis of a year of three hundred and sixty five (365) days.
- 1.2.8 The words "hereof" or "herein", if and when used in this Agreement shall mean a reference to this Agreement.
- 1.2.9 The contents of Schedule 7 shall be referred to for ascertaining accuracy and correctness of the representations made by the Selected Bidder in Article 17.2.1 hereof.



ARTICLE: 2**2 EFFECTIVENESS AND TERM OF AGREEMENT****2.1 Effective Date:**

This Agreement shall be effective from later of the dates of the following events:

- a. The Selected Bidder, on behalf of the TSP, has provided the Contract Performance Guarantee, as per terms of Article 3.1 of this Agreement; and
- b. The Selected Bidder has acquired for the Acquisition Price, one hundred percent (100%) of the equity shareholding of REC Power Development and Consultancy Limited in Kallam Transco Limited along with all its related assets and liabilities as per the provisions of the Share Purchase Agreement. and
- c. The Agreement is executed and delivered by the Parties;

2.2 Term and Termination:

2.2.1 Subject to Article 2.2.3 and Article 2.4, this Agreement shall continue to be effective in relation to the Project until the Expiry Date, when it shall automatically terminate.

2.2.2 Post the Expiry Date of this Agreement, the TSP shall ensure transfer of Project Assets to CTU or its successors or an agency as decided by the Central Government at zero cost and free from any encumbrance and liability. The transfer shall be completed within 90 days of expiry of this Agreement failing which CTU shall be entitled to take over the Project Assets Suo moto.

2.2.3 This Agreement shall terminate before the Expiry Date in accordance with Article 13 or Article 3.3.2 or Article 3.3.4.

2.3 Conditions prior to the expiry of the Transmission License

2.3.1 In order to continue the Project beyond the expiry of the Transmission License, the TSP shall be obligated to make an application to the Commission at least two (2) years before the date of expiry of the Transmission License, seeking the Commission's approval for the extension of the term of the Transmission License up to the Expiry Date.

2.3.2 The TSP shall timely comply with all the requirements that may be laid down by the Commission for extension of the term of the Transmission License beyond the initial term of twenty-five (25) years & upto the Expiry Date and the TSP shall keep the Nodal Agency fully informed about the progress on its application for extension of the term of the Transmission License.

2.4 Survival:

The expiry or termination of this Agreement shall not affect any accrued rights, obligations/ roles and liabilities of the Parties under this Agreement, including the right to receive liquidated damages as per the terms of this Agreement, nor shall it effect the survival of any continuing obligations/ roles for which this Agreement provides, either expressly or by necessary implication, which are to survive after the Expiry Date or termination including those under Articles 3.3.3, 3.3.5, Article 9.3 (Application of Insurance Proceeds), Article 11 (Force Majeure), Article 13 (Events of Default and Termination), Article 14 (Liability & Indemnification), Article 16 (Governing Law & Dispute Resolution), Article 19 (Miscellaneous).

2.5 Applicability of the provisions of this Agreement

2.5.1 For the purpose of Availability, Target Availability and the computation of Availability, Incentive, Penalty, the provisions provided in this Agreement shall apply and any future modifications in the relevant Rules and Regulations shall not be applicable for this Project.

2.5.2 For the purposes of this Agreement for ISTS systems developed under the tariff based competitive bidding framework, the provisions relating to the definitions (Availability and COD), Article 3 (Contract Performance Guarantee and Conditions Subsequent), Article 5 (Construction of the Project), Article 6 (Connection and Commissioning of the Project), Article 8 (Target Availability and calculation of Availability), Article 11 (Force Majeure), Article 12 (Change in Law), Article 13 (Event of Default), Article 14 (Indemnification), Article 15 (Assignment and Charges), Articles 16.1, 16.2 and 16.4 (Governing Laws and Dispute Resolution) and Article 17 (representation and warranties of the ISTS Licensee) of this agreement shall supersede the corresponding provisions under Sharing Regulations.



ARTICLE: 3**3 CONDITIONS SUBSEQUENT****3.1 Satisfaction of conditions subsequent by the TSP**

3.1.1 Within ten (10) days from the date of issue of Letter of Intent, the Selected Bidder, shall:

- a. Provide the Contract Performance Guarantee, and
- b. Acquire, for the Acquisition Price, one hundred percent (100%) equity shareholding of Kallam Transco Limited from REC Power Development and Consultancy Limited, who shall sell to the Selected Bidder, the equity shareholding of Kallam Transco Limited, along with all its related assets and liabilities.
- c. Execute this Agreement;

The TSP shall, within five (5) working days from the date of acquisition of SPV by the Selected Bidder, undertake to apply to the Commission for the grant of Transmission License and for the adoption of tariff as required under section-63 of the Electricity Act.

The Selected Bidder, on behalf of the TSP, will provide to the Central Transmission Utility of India Limited (being the Nodal Agency) the Contract Performance Guarantee for an amount of Rs. 3.0 (Rupees Three Crore only).

3.1.2 The Contract Performance Guarantee shall be initially valid for a period up to three (3) months after the Scheduled COD of the Project and shall be extended from time to time to be valid for a period up to three (3) months after the COD of the Project. In case the validity of the Contract Performance Guarantee is expiring before the validity specified in this Article, the TSP shall, at least thirty (30) days before the expiry of the Contract Performance Guarantee, replace the Contract Performance Guarantee with another Contract Performance Guarantee or extend the validity of the existing Contract Performance Guarantee until the validity period specified in this Article.

3.1.3 The TSP agrees and undertakes to duly perform and complete the following activities within six (6) months from the Effective Date (except for c) below), unless such completion is affected due to any Force Majeure Event, or if any of the activities is specifically waived in writing



by the Nodal Agency:

- a. To obtain the Transmission License for the Project from the Commission;
- b. To obtain the order for adoption of Transmission Charges by the Commission, as required under Section 63 of the Electricity Act 2003;
- c. To submit to the Nodal Agency, CEA & Independent Engineer, the Project Execution Plan, immediately after award of contract(s) and maximum within one hundred and twenty (120) days from the Effective Date. Also, an approved copy each of Manufacturing Quality Plan (MQP) and Field Quality Plan (FQP) would be submitted to Independent Engineer & Nodal Agency in the same time period. The TSP's Project Execution Plan should be in conformity with the Scheduled COD as specified in Schedule 2 of this Agreement, and shall bring out clearly the organization structure, time plan and methodology for executing the Project, award of major contracts, designing, engineering, procurement, shipping, construction, testing and commissioning to commercial operation;
- d. To submit to the Nodal Agency, CEA & Independent Engineer a detailed bar (GANTT) chart of the Project outlining each activity (taking longer than one Month), linkages as well as durations;
- e. To submit to the Nodal Agency, CEA & Independent Engineer detailed specifications of conductor meeting the functional specifications specified in RFP;
- f. To achieve Financial Closure;
- g. To provide an irrevocable letter to the Lenders duly accepting and acknowledging the rights provided to the Lenders under the provisions of Article 15.3 of this Agreement and all other RFP Project Documents;
- h. To award the Engineering, Procurement and Construction contract ("EPC contract") for the design and construction of the Project and shall have given to such Contractor an irrevocable notice to proceed; and
- i. To sign the Agreement(s) required, if any, under Sharing Regulations.



Central Transmission Utility of India Limited

21



Kallam Transco Limited

1 April 2024

3.2 Recognition of Lenders' Rights by the Nodal Agency

3.2.1 The Nodal Agency hereby accepts and acknowledges the rights provided to the Lenders as per Article 15.3 of this Agreement and all other RFP Project Documents.

3.3 Consequences of non-fulfilment of conditions subsequent

3.3.1 If any of the conditions specified in Article 3.1.3 is not duly fulfilled by the TSP even within three (3) Months after the time specified therein, then on and from the expiry of such period and until the TSP has satisfied all the conditions specified in Article 3.1.3, the TSP shall, on a monthly basis, be liable to furnish to Central Transmission Utility of India Limited (being the Nodal Agency) additional Contract Performance Guarantee of Rs. 0.30 Crore (Rupees Thirty Lakhs Only) within two (2) Business Days of expiry of every such Month. Such additional Contract Performance Guarantee shall be provided to Central Transmission Utility of India Limited (being the Nodal Agency) in the manner provided in Article 3.1.1 and shall become part of the Contract Performance Guarantee and all the provisions of this Agreement shall be construed accordingly. Central Transmission Utility of India Limited (being the Nodal Agency) shall be entitled to hold and / or invoke the Contract Performance Guarantee, including such additional Contract Performance Guarantee, in accordance with the provisions of this Agreement.

3.3.2 Subject to Article 3.3.4, if:

- (i) the fulfilment of any of the conditions specified in Article 3.1.3 is delayed beyond nine (9) Months from the Effective Date and the TSP fails to furnish additional Contract Performance Guarantee to the Nodal Agency in accordance with Article 3.3.1 hereof; or
- (ii) the TSP furnishes additional Performance Guarantee to the Nodal Agency in accordance with Article 3.3.1 hereof but fails to fulfil the conditions specified in Article 3.1.3 within a period of twelve (12) months from the Effective Date,

the Nodal Agency shall have the right to terminate this Agreement, by giving a Termination Notice to the TSP, in writing, of at least seven (7) days, with a copy to CEA and the Lenders' Representative in order to enable the Lenders to exercise right of substitution in accordance with Article 15.3 of this Agreement.



Central Transmission Utility of India Limited

22



Kallam Transco Limited

1 April 2024

3.3.3 If the Nodal Agency elects to terminate this Agreement as per the provisions of Article 3.3.2, the TSP shall be liable to pay to the Nodal Agency an amount of Rs. 3.0 Crore (Rupees Three Crore only) as liquidated damages. The Nodal Agency shall be entitled to recover this amount of damages by invoking the Contract Performance Guarantee to the extent of liquidated damages, which shall be required by the Nodal Agency, and the balance shall be returned to TSP, if any.

It is clarified for removal of doubt that this Article shall survive the termination of this Agreement.

3.3.4 In case of inability of the TSP to fulfil the conditions specified in Article 3.1.3 due to any Force Majeure Event, the time period for fulfilment of the condition subsequent as mentioned in Article 3.1.3, may be extended for a period of such Force Majeure Event. Alternatively, if deemed necessary, this Agreement may be terminated by the Nodal Agency by giving a Termination Notice to the TSP, in writing, of at least seven (7) days, with a copy to CEA and the Lenders' Representative in order to enable the Lenders to exercise right of substitution in accordance with Article 15.3 of this Agreement and the Contract Performance Guarantee shall be returned as per the provisions of Article 6.5.1.

Provided, that due to the provisions of this Article 3.3.4, any increase in the time period for completion of conditions subsequent mentioned under Article 3.1.3, shall lead to an equal increase in the time period for the Scheduled COD. If the Scheduled COD is extended beyond a period of one hundred eighty (180) days due to the provisions of this Article 3.3.4, the TSP will be allowed to recover the interest cost during construction corresponding to the period exceeding one hundred eighty (180) days by adjustment in the Transmission Charges in accordance with Schedule 9.

3.3.5 Upon termination of this Agreement as per Articles 3.3.2 and 3.3.4, the Nodal Agency may take steps to bid out the Project again.

3.3.6 The Nodal agency, on the failure of the TSP to fulfil its obligations, if it considers that there are sufficient grounds for so doing, apart from invoking the Contract Performance Guarantee under para 3.3.3 may also initiate proceedings for blacklisting the TSP as per provisions of Article 13.2 of TSA.



3.4 Progress Reports

The TSP shall notify the Nodal Agency and CEA in writing at least once a Month on the progress made in satisfying the conditions subsequent in Articles 3.1.3.



ARTICLE: 4**4 DEVELOPMENT OF THE PROJECT****4.1 TSP's obligations in development of the Project:**

Subject to the terms and conditions of this Agreement, the TSP at its own cost and expense shall observe, comply with, perform, undertake and be responsible:

- a. for procuring and maintaining in full force and effect all Consents, Clearances and Permits, required in accordance with Law for development of the Project;
- b. for financing, constructing, owning and commissioning each of the Element of the Project for the scope of work set out in Schedule 1 of this Agreement in accordance with:
 - i. the Electricity Act and the Rules made thereof;
 - ii. the Grid Code;
 - iii. the CEA Regulations applicable, and as amended from time to time, for Transmission Lines and sub-stations:
 - the Central Electricity Authority (Technical Standards for Connectivity to the Grid) Regulations, 2007;
 - Central Electricity Authority (Technical Standards for construction of Electrical Plants and Electric Lines) Regulation, 2010;
 - Central Electricity Authority (Grid Standard) Regulations, 2010;
 - Central Electricity Authority (Safety requirements for construction, operation and maintenance of Electrical Plants and Electrical Lines) Regulation, 2011;
 - Central Electricity Authority (Measures relating to Safety and Electricity Supply) Regulation, 2010;
 - Central Electricity Authority (Technical Standards for Communication System in Power System Operation) Regulations, 2020.

Transmission Service Agreement

iv. Safety/ security Guidelines laid down by the Government;

v. Prudent Utility Practices, relevant Indian Standards and the Law;

not later than the Scheduled COD as per Schedule 2 of this Agreement;

- c. for entering into a Connection Agreement with the concerned parties in accordance with the Grid Code.
- d. for owning the Project throughout the term of this Agreement free and clear of any encumbrances except those expressly permitted under Article 15 of this Agreement;
- e. to co-ordinate and liaise with concerned agencies and provide on a timely basis relevant information with regard to the specifications of the Project that may be required for interconnecting the Project with the Interconnection Facilities;
- f. for providing all assistance to the Arbitrators as they may require for the performance of their duties and responsibilities;
- g. to provide to the Nodal Agency and CEA, on a monthly basis, progress reports with regard to the Project and its execution (in accordance with prescribed form) to enable the CEA to monitor and co-ordinate the development of the Project matching with the Interconnection Facilities;
- h. to comply with Ministry of Power order no. 25-11/6/2018 – PG dated 02.07.2020 as well as other Guidelines issued by Govt. of India pertaining to this;
- i. to procure the products associated with the Transmission System as per provisions of Public Procurement (Preference to Make in India) orders issued by Ministry of Power vide orders No. 11/5/2018 - Coord. dated 28.07.2020 for transmission sector, as amended from time to time read with Department for Promotion of Industry and Internal Trade (DPIIT) orders in this regard (Procuring Entity as defined in above orders shall deemed to have included Selected Bidder and/ or TSP).

Also, to comply with Department of Expenditure, Ministry of Finance vide Order (Public Procurement No 1) bearing File No. 6/18/2019-PPD dated 23.07.2020, Order (Public

Transmission Service Agreement

Procurement No 2) bearing File No. 6/18/2019-PPD dated 23.07.2020 and Order (Public Procurement No. 3) bearing File No. 6/18/2019-PPD, dated 24.07.2020, as amended from time to time, regarding public procurement from a bidder of a country, which shares land border with India;

- j. to submit to Nodal Agency information in the prescribed format [To be devised by Nodal Agency] for ensuring compliance to Article 4.1 i) above.
- k. to comply with all its obligations undertaken in this Agreement.

4.2 Roles of the Nodal Agency in implementation of the Project:

4.2.1 Subject to the terms and conditions of this Agreement, the Nodal Agency shall be the holder and administrator of this Agreement and shall inter alia:

- a. appoint an Independent Engineer within 90 days of the Effective Date
- b. provide letters of recommendation to the concerned Indian Governmental Instrumentality, as may be requested by the TSP from time to time, for obtaining the Consents, Clearances and Permits required for the Project;
- c. coordinate among TSP and upstream/downstream entities in respect of Interconnection Facilities; and
- d. monitor the implementation of the Agreement and take appropriate action for breach thereof including revocation of guarantees, cancellation of Agreement, blacklisting etc
- e. provide all assistance to the Arbitrators as required for the performance of their duties and responsibilities; and
- f. perform any other responsibility (ies) as specified in this Agreement.

4.3 Time for Commencement and Completion:

- a. The TSP shall take all necessary steps to commence work on the Project from the Effective Date of the Agreement and shall achieve Scheduled COD of the Project in accordance with the time schedule specified in Schedule 2 of this Agreement;



Transmission Service Agreement

- b. The COD of each Element of the Project shall occur no later than the Scheduled COD or within such extended time to which the TSP shall be entitled under Article 4.4 hereto.

4.4 Extension of time:

- 4.4.1 In the event that the TSP is unable to perform its obligations for the reasons solely attributable to the Nodal Agency, the Scheduled COD shall be extended, by a 'day to day' basis, subject to the provisions of Article 13.
- 4.4.2 In the event that an Element or the Project cannot be commissioned by its Scheduled COD on account of any Force Majeure Event as per Article 11, the Scheduled COD shall be extended, by a 'day to day' basis for a period of such Force Majeure Event. Alternatively, if deemed necessary, the Nodal Agency may terminate the Agreement as per the provisions of Article 13.4 by giving a Termination Notice to the TSP, in writing, of at least seven (7) days, with a copy to CEA and the Lenders' Representative in order to enable the Lenders to exercise right of substitution in accordance with Article 15.3 of this Agreement.
- 4.4.3 If the Parties have not agreed, within thirty (30) days after the affected Party's performance has ceased to be affected by the relevant circumstance, on how long the Scheduled COD should be deferred by, any Party may raise the Dispute to be resolved in accordance with Article 16.

4.5 Metering Arrangements:

- 4.5.1 The TSP shall comply with all the provisions of the IEGC and the Central Electricity Authority (Installation and Operation of Meters) Regulations, 2006 as amended from time to time, with regard to the metering arrangements for the Project. The TSP shall fully cooperate with the CTU / STU / RLDC and extend all necessary assistance in taking meter readings.

4.6 Interconnection Facilities:

- 4.6.1 Subject to the terms and conditions of this Agreement, the TSP shall be responsible for connecting the Project with the interconnection point(s) specified in Schedule 1 of this Agreement. The Interconnection Facilities shall be developed as per the scope of work and responsibilities assigned in Schedule 1 of this Agreement. The Nodal Agency shall be responsible for coordinating to make available the Interconnection Facilities.



Transmission Service Agreement

4.6.2 In order to remove any doubts, it is made clear that the obligation of the TSP within the scope of the project is to construct the Project as per Schedule-1 of this Agreement and in particular to connect it to the Interconnection Facilities as specified in this Agreement.



ARTICLE: 5**5 CONSTRUCTION OF THE PROJECT****5.1 TSP's Construction Responsibilities:**

- 5.1.1 The TSP, at its own cost and expense, shall be responsible for designing, constructing, erecting, testing and commissioning each Element of the Project by the Scheduled COD in accordance with the Regulations and other applicable Laws specified in Article 4.1 of this Agreement.
- 5.1.2 The TSP acknowledges and agrees that it shall not be relieved from any of its obligations under this Agreement or be entitled to any extension of time or any compensation whatsoever by reason of the unsuitability of the Site or Transmission Line route(s).
- 5.1.3 The TSP shall be responsible for obtaining all Consents, Clearances and Permits related but not limited to road / rail / river / canal / power line / crossings, Power and Telecom Coordination Committee (PTCC), defence, civil aviation, right of way / way-leaves and environmental & forest clearances from relevant authorities required for developing, financing, constructing, maintaining/ renewing all such Consents, Clearances and Permits in order to carry out its obligations under this Agreement in general and shall furnish to the Nodal Agency such copy/ies of each Consents, Clearances and Permits, on demand. Nodal Agency shall provide letters of recommendation to the concerned Indian Governmental Instrumentality, as may be requested by the TSP from time to time, for obtaining the Consents, Clearances and Permits required for the Project.
- 5.1.4 The TSP shall be responsible for:
- (a) Deleted;
 - (b) Deleted;
 - (c) survey and geo-technical investigation of line route in order to determine the final route of the Transmission Lines;

- (d) seeking access to the Site and other places where the Project is being executed, at its own risk and costs, including payment of any crop, tree compensation or any other compensation as may be required.

5.1.5 In case the Project involves any resettlement and rehabilitation, the resettlement and rehabilitation package will be implemented by the State Government authorities, for which the costs is to be borne by the TSP and no changes would be allowed in the Transmission Charges on account of any variation in the resettlement and rehabilitation cost. The TSP shall provide assistance on best endeavour basis, in implementation of the resettlement and rehabilitation package, if execution of such package is in the interest of expeditious implementation of the Project and is beneficial to the Project affected persons.

5.2 Appointing Contractors:

5.2.1 The TSP shall conform to the requirements as provided in this Agreement while appointing Contractor(s) for procurement of goods & services.

5.2.2 The appointment of such Contractor(s) shall neither relieve the TSP of any of its obligations under this Agreement nor make the Nodal Agency liable for the performance of such Contractor(s).

5.3 Monthly Progress Reporting:

The TSP shall provide to the CEA, Nodal Agency & Independent Engineer, on a monthly basis, progress reports along with likely completion date of each Element with regard to the Project and its execution (in accordance with prescribed form). The Nodal Agency/ CEA shall monitor the development of the Project for its timely completion for improving and augmenting the electricity system as a part of its statutory responsibility.

5.4 Quality of Workmanship:

The TSP shall ensure that the Project is designed, built and completed in a good workmanship using sound engineering and construction practices, and using only materials and equipment that are new and manufactured as per the MQP and following approved FQP for erection, testing & commissioning and complying with Indian /International Standards such



that, the useful life of the Project will be at least thirty-five (35) years from the COD of the Project.

The TSP shall ensure that all major substation equipment / component (e.g. transformers, reactors, Circuit Breakers, Instrument Transformers (IT), Surge Arresters (SA), Protection relays, clamps & connectors etc.), equipment in terminal stations of HVDC installations including Thyristor/ IGBT valves, Converter Transformers, smoothing reactors, Transformer bushings and wall bushings, GIS bus ducts, towers and gantry structures and transmission towers or poles and line materials (conductors, earthwire, OPGW, insulator, accessories for conductors, OPGW & earthwires, hardware fittings for insulators, aviation lights etc), facilities and system shall be designed, constructed and tested (Type test, Routine tests, Factory Acceptance Test (FAT)) in accordance with relevant CEA Regulations and Indian Standards. In case Indian Standards for any particular equipment/ system/ process is not available, IEC/ IEEE or equivalent International Standards and Codes shall be followed.

5.5 Progress Monitoring & Quality Assurance:

- 5.5.1 The Project Execution Plan submitted by the TSP in accordance with Article 3.1.3 c) shall comprise of detailed schedule of all the equipments/items /materials required for the Project, right from procurement of raw material till the dispatch from works and receipt at the site. Further, it should also include various stages of the construction schedule up to the commissioning of the Project.
- 5.5.2 Nodal Agency, CEA & Independent Engineer shall have access at all reasonable times to the Site and to the Manufacturer's works and to all such places where the Project is being executed.
- 5.5.3 Independent Engineer shall ensure conformity of the conductor specifications with the functional specifications specified in RFP.
- 5.5.4 The Independent Engineer shall monitor the following during construction of the Project:
- Quality of equipments, material, foundation, structures and workmanship etc. as laid down in Article 5.4 and 6.1.4 of the TSA. Specifically, quality of Sub-station equipments, transmission line material and workmanship etc. would be checked in accordance with the Article 5.4.

b) Progress in the activities specified in Condition Subsequent



- c) Verification of readiness of the elements including the statutory clearances & completion of civil works, fixing of all components and finalisation of punch points (if any) prior to charging of the elements
- d) Progress of construction of substation and Transmission Lines

5.5.5 The progress shall be reviewed by the Independent Engineer against the Project Execution Plan. The Independent Engineer shall prepare its report on monthly basis and submit the same to Nodal Agency highlighting the progress achieved till the end of respective month vis-à-vis milestone activities, areas of concern, if any, which may result in delay in the timely completion of the Project. Based on the progress, Nodal Agency and/ or CEA shall issue written instructions to the TSP to take corrective measures, as may be prudent for the timely completion of the Project. In case of any deficiency, the Nodal Agency would be at liberty to take action in accordance with the procedure of this Agreement.

5.5.6 For any delay in commissioning any critical Element(s), as identified in Schedule 1 & Schedule 2 of this Agreement, beyond a period of 45 days shall lead to a sequestration of 10% of the Contract Performance Guarantee.

5.6 Site regulations and Construction Documents

The TSP shall abide by the Safety Rules and Procedures as mentioned in Schedule 3 of this Agreement

The TSP shall retain at the Site and make available for inspection at all reasonable times, copies of the Consents, Clearances and Permits, construction drawings and other documents related to construction.

5.7 Supervision of work:

The TSP shall provide all necessary superintendence for execution of the Project and its supervisory personnel shall be available to provide full-time superintendence for execution of the Project. The TSP shall provide skilled personnel who are experienced in their respective fields.

5.8 Remedial Measures:

The TSP shall take all necessary actions for remedying the shortfall in achievement of timely progress in execution of the Project, if any, as intimated by the Independent Engineer and/ or CEA and/ or the Nodal Agency. However, such intimation by the Independent Engineer and/ or CEA and/ or the Nodal Agency and the subsequent effect of such

Transmission Service Agreement

remedial measures carried out by the TSP shall not relieve the TSP of its obligations in the Agreement. Independent Engineer and/ or CEA and/ or the Nodal Agency may carry out random inspections during the Project execution, as and when deemed necessary by it. If the shortfalls as intimated to the TSP are not remedied to the satisfaction of the CEA and/ or the Nodal Agency, this Agreement may be terminated by the Nodal Agency by giving a Termination Notice to the TSP, in writing, of at least seven (7) days, with a copy to CEA and the Lenders' Representative in order to enable the Lenders to exercise right of substitution in accordance with Article 15.3 of this Agreement.



ARTICLE: 6**6 CONNECTION AND COMMISSIONING OF THE PROJECT****6.1 Connection with the Inter-Connection Facilities:**

6.1.1 The TSP shall give the RLDC(s), CTU, / STU, as the case may be, and any other agencies as required, at least sixty (60) days advance written notice of the date on which it intends to connect an Element of the Project, which date shall not be earlier than its Scheduled COD or Schedule COD extended as per Article 4.4.1 & 4.4.2 of this Agreement, unless mutually agreed to by Parties. Further, any preponing of COD of any element prior to Scheduled COD must be approved by the Nodal Agency.

6.1.2 The RLDC / SLDC (as the case may be) or the CTU / STU (as the case may be), for reasonable cause, including non-availability of Interconnection Facilities as per Article 4.2, can defer the connection for up to fifteen (15) days from the date notified by the TSP pursuant to Article 6.1.1, if it notifies to the TSP in writing, before the date of connection, of the reason for the deferral and when the connection is to be rescheduled. However, no such deferment on one or more occasions would be for more than an aggregate period of thirty (30) days. Further, the Scheduled COD would be extended as required, for all such deferments on "day to day" basis.

6.1.3 Subject to Articles 6.1.1 and 6.1.2, any Element of Project may be connected with the Interconnection Facilities when:

- a. it has been completed in accordance with this Agreement and the Connection Agreement;
- b. it meets the Grid Code, Central Electricity Authority (Technical Standards for Connectivity to the Grid) Regulations, 2007 as amended from time to time and all other Indian legal requirements, and
- c. The TSP has obtained the approval in writing of the Electrical Inspector certifying that the Element is ready from the point of view of safety of supply and can be connected with the Interconnection Facilities.
- d. It has satisfactorily met all the testing requirements as per Articles 6.1.4



6.1.4 Site Acceptance Test (SAT)/ pre-commissioning tests of all major substation equipment, component, system, facilities shall be successfully carried out before commissioning. The Type tests, FAT and SAT reports should be available at the substation / terminal station of HVDC installations for ready reference of operation and maintenance staff and has to be made available to the Independent Engineer appointed for quality monitoring or their authorised representatives, as and when they wish to examine the same.

6.2 Commercial Operation:

6.2.1 An Element of the Project shall be declared to have achieved COD twenty four (24) hours following the connection of the Element with the Interconnection Facilities pursuant to Article 6.1 or seven (7) days after the date on which it is declared by the TSP to be ready for charging but is not able to be charged for reasons not attributable to the TSP subject to Article 6.1.2.

Provided that an Element shall be declared to have achieved COD only after all the Element(s), if any, which are pre-required to have achieved COD as defined in Schedule 2 of this Agreement, have been declared to have achieved their respective COD.

6.2.2 Once any Element of the Project has been declared to have achieved deemed COD as per Article 6.2.1 above, such Element of the Project shall be deemed to have Availability equal to the Target Availability till the actual charging of the Element and to this extent, TSP shall be eligible for the Monthly Transmission Charges applicable for such Element

6.3 Compensation for Direct Non Natural Force Majeure Event or Indirect Non Natural Force Majeure Event or Natural Force Majeure Event (affecting the Nodal Agency)

6.3.1 If the TSP is otherwise ready to connect the Element(s) of the Project and has given due notice, as per provisions of Article 6.1.1, to the concerned agencies of the date of intention to connect the Element(s) of the Project, where such date is not before the Scheduled COD, but is not able to connect the Element(s) of the Project by the said date specified in the notice, due to Direct Non Natural Force Majeure Event or Indirect Non Natural Force Majeure Event or Natural Force Majeure Event affecting the Nodal Agency, provided such Direct Non Natural Force Majeure Event or Indirect Non Natural Force Majeure Event or Natural



Force Majeure Event affecting the Nodal Agency has continued for a period of more than three (3) continuous or non-continuous Months, the TSP shall, until the effects of the Direct Non Natural Force Majeure Event or of Indirect Non Natural Force Majeure Event or Natural Force Majeure Event affecting the Nodal Agency no longer prevent the TSP from connecting the Element(s) of the Project, be deemed to have achieved COD relevant to that date and to this extent, be deemed to have been providing Transmission Service with effect from the date notified, and shall be treated as follows:

- a. In case of delay due to Direct Non Natural Force Majeure Event, TSP is entitled for Transmission Charges calculated on Target Availability for the period of such events in excess of three (3) continuous or non-continuous Months in the manner provided in (c) below.
- b. In case of delay due to Indirect Non Natural Force Majeure Event or Natural Force Majeure Event affecting the Nodal Agency, TSP is entitled for payment for debt service which is due under the Financing Agreements, subject to a maximum of Transmission Charges calculated on Target Availability, for the period of such events in excess of three (3) continuous or non-continuous Months in the manner provided in (c) below.
- c. In case of delay due to Direct Non Natural Force Majeure Event or Indirect Non Natural Force Majeure Event or Natural Force Majeure Event affecting the Nodal Agency, the TSP is entitled for payments mentioned in (a) and (b) above, after commencement of Transmission Service, in the form of an increase in Transmission Charges. These amounts shall be paid from the date, being the later of a) the date of cessation of such Indirect Non Natural Force Majeure Event or Natural Force Majeure Event affecting the Nodal Agency and b) the completion of sixty (60) days from the receipt of the Financing Agreements by the Nodal Agency from the TSP.

Provided such increase in Transmission Charges shall be so as to put the TSP in the same economic position as the TSP would have been in case the TSP had been paid amounts mentioned in (a) and (b) above in a situation where the Force Majeure Event had not occurred.

For the avoidance of doubt, it is clarified that the charges payable under this Article 6.3.1 shall be recovered as per Sharing Regulations.

6.4 Liquidated Damages for Delay in achieving COD of Project:

6.4.1 If the TSP fails to achieve COD of any Element of the Project or the Project, by the Element's / Project's Scheduled COD or such Scheduled COD as extended under Articles 4.4.1 and 4.4.3, then the TSP shall pay to the Nodal Agency, a sum equivalent to 3.33% of Monthly Transmission Charges applicable for the Element of the Project [in case where no Elements have been defined, to be on the Project as a whole] / Project, for each day of delay up to sixty (60) days of delay and beyond that time limit, at the rate of five percent (5%) of the Monthly Transmission Charges applicable to such Element / Project, as liquidated damages for such delay and not as penalty, without prejudice to any rights of the Nodal Agency under the Agreement.

6.4.2 The TSP's maximum liability under this Article 6.4 shall be limited to the amount of liquidated damages calculated in accordance with Article 6.4.1 for and up to six (6) months of delay for the Element or the Project.

Provided that, in case of failure of the TSP to achieve COD of the Element of the Project even after the expiry of six (6) months from its Scheduled COD, the provisions of Article 13 shall apply.

6.4.3 The TSP shall make payment to the Nodal Agency of the liquidated damages calculated pursuant to Article 6.4.1 within ten (10) days of the earlier of:

- a. the date on which the applicable Element achieves COD; or
- b. the date of termination of this Agreement.

The payment of such damages shall not relieve the TSP from its obligations to complete the Project or from any other obligation and liabilities under the Agreement.

6.4.4 If the TSP fails to pay the amount of liquidated damages to the Nodal Agency within the said period of ten (10) days, the Nodal Agency shall be entitled to recover the said amount of the liquidated damages by invoking the Contract Performance Guarantee. If the then existing Contract Performance Guarantee is for an amount which is less than the amount of the liquidated damages payable by the TSP to the Nodal Agency under this Article 6.3 and the TSP fails to make payment of the balance amount of the liquidated damages not covered by the Contract Performance Guarantee, then such balance amount shall be deducted from the Transmission Charges payable to the TSP. The right of the



Nodal Agency to encash the Contract Performance Guarantee is without prejudice to the other rights of the Nodal Agency under this Agreement.

6.4.5 For avoidance of doubt, it is clarified that amount payable by TSP under this Article is over and above the penalty payable by TSP under Article 5.5.6 of this Agreement.

6.5 Return of Contract Performance Guarantee

6.5.1 The Contract Performance Guarantee as submitted by TSP in accordance with Article 3.1.1 shall be released by the Nodal Agency within three (3) months from the COD of the Project. In the event of delay in achieving Scheduled COD of any of the Elements by the TSP (otherwise than due to reasons as mentioned in Article 3.1.3 or Article 11) and consequent part invocation of the Contract Performance Guarantee by the Nodal Agency, Nodal Agency shall release the Contract Performance Guarantee, if any remaining unadjusted, after the satisfactory completion by the TSP of all the requirements regarding achieving the Scheduled COD of the remaining Elements of the Project. It is clarified that the Nodal Agency shall also return / release the Contract Performance Guarantee in the event of (i) applicability of Article 3.3.2 to the extent the Contract Performance Guarantee is valid for an amount in excess of Rs. 3.0 Crore (Rupees Three Crore only), or (ii) termination of this Agreement by the Nodal Agency as mentioned under Article 3.3.4 of this Agreement.

6.5.2 The release of the Contract Performance Guarantee shall be without prejudice to other rights of the Nodal Agency under this Agreement.



Central Transmission Utility of India Limited

39



Kallam Transco Limited

1 April 2024

ARTICLE: 7

7 OPERATION AND MAINTENANCE OF THE PROJECT

7.1 Operation and Maintenance of the Project:

The TSP shall be responsible for ensuring that the Project is operated and maintained in accordance with the regulations made by the Commission and CEA from time to time and provisions of the Act.



Central Transmission Utility of India Limited



Kallam Transco Limited

ARTICLE: 8**8 AVAILABILITY OF THE PROJECT****8.1 Calculation of Availability of the Project:**

Calculation of Availability for the Elements and for the Project, as the case may be, shall be as per Appendix –II to Central Electricity Regulatory Commission (Terms and Conditions of Tariff) Regulations, 2019, as applicable on the Bid Deadline and as appended in Schedule 6 of this Agreement.

8.2 Target Availability:

The Target Availability of each Element and the Project shall be 98%.

Payment of monthly Transmission charges based on actual availability will be calculated as per para 1.2 of Schedule 4 of this Agreement.

If the availability of any Element or the Project is below the Target Availability, for six consecutive months in a Contract Year, the DIC(s) or the Nodal Agency may issue a show cause notice to the TSP, asking them to show cause as to why the Transmission Service Agreement be not terminated, and if no satisfactory cause is shown it may terminate the Agreement. If the Nodal Agency is of the opinion that the transmission system is of critical importance, it may carry out or cause to carry the operation and maintenance of transmission system at the risk and cost of TSP.

ARTICLE: 9**9 INSURANCES****9.1 Insurance:**

- 9.1.1 The TSP shall effect and maintain or cause to be effected and maintained during the Construction Period and the Operating Period, adequate Insurances against such risks, with such deductibles including but not limited to any third party liability and endorsements and co-beneficiary/insured, as may be necessary under
- a. any of the Financing Agreements,
 - b. the Laws, and
 - c. in accordance with Prudent Utility Practices.

The Insurances shall be taken effective from a date prior to the date of the Financial Closure till the Expiry Date.

9.2 Evidence of Insurance cover:

- 9.2.1 The TSP shall furnish to the Nodal Agency copies of certificates and policies of the Insurances, as and when the Nodal Agency may seek from the TSP as per the terms of Article 9.1

9.3 Application of Insurance Proceeds:

- 9.3.1 Save as expressly provided in this Agreement, the policies of Insurances and the Financing Agreements, the proceeds of any insurance claim made due to loss or damage to the Project or any part of the Project shall be first applied to reinstatement, replacement or renewal of such loss or damage.
- 9.3.2 If a Natural Force Majeure Event renders the Project no longer economically and technically viable and the insurers under the Insurances make payment on a "total loss" or equivalent basis, the portion of the proceeds of such Insurance available to the TSP (after making admissible payments to the Lenders as per the Financing Agreements) shall be allocated only to the TSP. Nodal Agency and / or concerned Designated ISTS Customers shall have no claim on such proceeds of the Insurance.



9.3.3 Subject to the requirements of the Lenders under the Financing Agreements, any dispute or difference between the Parties as to whether the Project is no longer economically and technically viable due to a Force Majeure Event or whether that event was adequately covered in accordance with this Agreement by the Insurances shall be determined in accordance with Article 16.

9.4 Effect on liability of the Nodal Agency / Designated ISTS Customers

9.4.1 The Nodal Agency and / or the Designated ISTS Customers shall have no financial obligations or liability whatsoever towards the TSP in respect of this Article 9.



ARTICLE: 10**10 BILLING AND PAYMENT OF TRANSMISSION CHARGES**

10.1 Subject to provisions of this Article 10, the Monthly Transmission Charges shall be paid to the TSP, in Indian Rupees, on monthly basis as per the provisions of the Sharing Regulations, from the date on which an Element(s) has achieved COD until the Expiry Date of this Agreement, unless terminated earlier and in line with the provisions of Schedule 4 of this Agreement.

10.2 Calculation of Monthly Transmission Charges:

The Monthly Transmission Charges for each Contract Year including Incentive & Penalty payment shall be calculated in accordance with the provisions of Schedule 4 of this Agreement.

10.3 Rebate & Late Payment Surcharge:

The rebate and late payment surcharge shall be governed as per Sharing Regulations.

10.4 Disputed Bills, Default in payment by the Designated ISTS Customers & Annual Reconciliation:

Any Disputed Bill, Default in payment by the Designated ISTS Customers & Annual Reconciliation shall be governed as per Sharing Regulations.



ARTICLE: 11**11 FORCE MAJEURE****11.1 Definitions**

11.1.1 The following terms shall have the meanings given hereunder.

11.2 Affected Party

11.2.1 An Affected Party means any Party whose performance has been affected by an event of Force Majeure.

11.2.2 Any event of Force Majeure shall be deemed to be an event of Force Majeure affecting the TSP only if the Force Majeure event affects and results in, late delivery of machinery and equipment for the Project or construction, completion, commissioning of the Project by Scheduled COD and/or operation thereafter;

11.3 Force Majeure

A 'Force Majeure' means any event or circumstance or combination of events and circumstances including those stated below that wholly or partly prevents or unavoidably delays an Affected Party in the performance of its obligations/ roles under this Agreement, but only if and to the extent that such events or circumstances are not within the reasonable control, directly or indirectly, of the Affected Party and could not have been avoided if the Affected Party had taken reasonable care or complied with Prudent Utility Practices:

(a) Natural Force Majeure Events:

- i. act of God, including, but not limited to drought, fire and explosion (to the extent originating from a source external to the Site), earthquake, volcanic eruption, landslide, flood, cyclone, typhoon, tornado, or exceptionally adverse weather conditions, which are in excess of the statistical measures for the last hundred (100) years; and
- ii. epidemic/ pandemic notified by Indian Governmental Instrumentality.

(b) Non-Natural Force Majeure Events :

- i. Direct Non-Natural Force Majeure Events



- Nationalization or compulsory acquisition by any Indian Governmental Instrumentality of any material assets or rights of the Affected Party; or
- the unlawful, unreasonable or discriminatory revocation of, or refusal to renew, any Consents, Clearances and Permits required by the Affected Party to perform their obligations/ roles under the RFP Project Documents or any unlawful, unreasonable or discriminatory refusal to grant any other Consents, Clearances and Permits required for the development/ operation of the Project, provided that a Competent Court of Law declares the revocation or refusal to be unlawful, unreasonable and discriminatory and strikes the same down; or
- any other unlawful, unreasonable or discriminatory action on the part of an Indian Governmental Instrumentality which is directed against the Project, provided that a Competent Court of Law declares the action to be unlawful, unreasonable and discriminatory and strikes the same down.

ii. Indirect Non - Natural Force Majeure Events

- act of war (whether declared or undeclared), invasion, armed conflict or act of foreign enemy, blockade, embargo, revolution, riot, insurrection, terrorist or military action; or
- radioactive contamination or ionising radiation originating from a source in India or resulting from any other Indirect Non Natural Force Majeure Event mentioned above, excluding circumstances where the source or cause of contamination or radiation is brought or has been brought into or near the Site by the Affected Party or those employed or engaged by the Affected Party; or
- industry-wide strikes and labour disturbances, having a nationwide impact in India.

11.4 Force Majeure Exclusions

11.4.1 Force Majeure shall not include (i) any event or circumstance which is within the reasonable control of the Parties and (ii) the following conditions, except to the extent that they are consequences of an event



of Force Majeure:

- (a) Unavailability, late delivery, or changes in cost of the machinery, equipment, materials, spare parts etc. for the Project;
- (b) Delay in the performance of any Contractors or their agents;
- (c) Non-performance resulting from normal wear and tear typically experienced in transmission materials and equipment;
- (d) Strikes or labour disturbance at the facilities of the Affected Party;
- (e) Insufficiency of finances or funds or the Agreement becoming onerous to perform; and
- (f) Non-performance caused by, or connected with, the Affected Party's:
 - i. negligent or intentional acts, errors or omissions;
 - ii. failure to comply with an Indian Law; or
 - iii. breach of, or default under this Agreement or any Project Documents.
- (g) Any error or omission in the survey report provided by BPC during the bidding process.

11.5 Notification of Force Majeure Event

11.5.1 The Affected Party shall give notice to the other Party of any event of Force Majeure as soon as reasonably practicable, but not later than seven (7) days after the date on which such Party knew or should reasonably have known of the commencement of the event of Force Majeure. If an event of Force Majeure results in a breakdown of communications rendering it unreasonable to give notice within the applicable time limit specified herein, then the Party claiming Force Majeure shall give such notice as soon as reasonably practicable after reinstatement of communications, but not later than one (1) day after such reinstatement.

Provided that, such notice shall be a pre-condition to the Affected Party's entitlement to claim relief under this Agreement. Such notice shall include full particulars of the event of Force Majeure, its effects on the Party claiming relief and the remedial measures proposed. The Affected



Party shall give the other Party regular reports on the progress of those remedial measures and such other information as the other Party may reasonably request about the Force Majeure.

- 11.5.2 The Affected Party shall give notice to the other Party of (i) the cessation of the relevant event of Force Majeure; and (ii) the cessation of the effects of such event of Force Majeure on the performance of its rights or obligations/ roles under this Agreement, as soon as practicable after becoming aware of each of these cessations.

11.6 Duty to perform and duty to mitigate

To the extent not prevented by a Force Majeure Event, the Affected Party shall continue to perform its obligations/ roles as provided in this Agreement. The Affected Party shall use its reasonable efforts to mitigate the effect of any event of Force Majeure as soon as practicable.

11.7 Available Relief for a Force Majeure Event

Subject to this Article 11,

- (a) no Party shall be in breach of its obligations/ roles pursuant to this Agreement to the extent that the performance of its obligations/ roles was prevented, hindered or delayed due to a Force Majeure Event;
- (b) each Party shall be entitled to claim relief for a Force Majeure Event affecting its performance in relation to its obligations/ roles under Articles 3.3.4, 4.4.2 and 6.3.1 of this Agreement.
- (c) For the avoidance of doubt, it is clarified that the computation of Availability of the Element(s) under outage due to Force Majeure Event, as per Article 11.3 affecting the TSP shall be as per Appendix –II to Central Electricity Regulatory Commission (Terms and Conditions of Tariff) Regulations, 2019 as on Bid Deadline. For the event(s) for which the Element(s) is/are deemed to be available as per Appendix –II to Central Electricity Regulatory Commission (Terms and Conditions of Tariff) Regulations, 2019, then the Transmission Charges, as applicable to such Element(s), shall be payable as per Schedule 4, for the duration of such event(s).
- (d) For so long as the TSP is claiming relief due to any Force Majeure Event under this Agreement, the Nodal Agency may, if it so desires, from time to time on one (1) day notice, inspect the Project and the



TSP shall provide the Nodal Agency's personnel with access to the Project to carry out such inspections.

- (e) For avoidance of doubt, the TSP acknowledges that for extension of Scheduled COD a period up to one hundred eighty (180) days due to Force Majeure event, no compensation on the grounds such as interest cost, incident expenditure, opportunity cost will be made to the TSP. However, if Scheduled COD is extended beyond a period of one hundred eighty (180) days due to Force Majeure event, the TSP will be allowed to recover the interest cost during construction corresponding to the period exceeding one hundred eighty (180) days by adjustment in the Transmission Charges in accordance with Schedule 9.



Central Transmission Utility of India Limited

49



Kallam Transco Limited

1 April 2024

ARTICLE: 12**12 CHANGE IN LAW****12.1 Change in Law**

12.1.1 Change in Law means the occurrence of any of the following after the Bid Deadline resulting into any additional recurring / non-recurring expenditure by the TSP or any savings of the TSP:

- the enactment, coming into effect, adoption, promulgation, amendment, modification or repeal (without re-enactment or consolidation) in India, of any Law, including rules and regulations framed pursuant to such Law, subject to the provisions under Article 12.1.2;
- a change in the interpretation or application of any Law by any Indian Governmental Instrumentality having the legal power to interpret or apply such Law, or any Competent Court of Law;
- the imposition of a requirement for obtaining any Consents, Clearances and Permits which was not required earlier;
- a change in the terms and conditions prescribed for obtaining any Consents, Clearances and Permits or the inclusion of any new terms or conditions for obtaining such Consents, Clearances and Permits;
- any change in the licensing regulations of the Commission, under which the Transmission License for the Project was granted if made applicable by such Commission to the TSP;
- change in wind zone; or
- any change in tax or introduction of any tax made applicable for providing Transmission Service by the TSP as per the terms of this Agreement.

12.1.2 Notwithstanding anything contained in this Agreement, Change in Law shall not cover any change:

- a) Taxes on corporate income; and
- b) Withholding tax on income or dividends distributed to the shareholders of the TSP.

12.2 Relief for Change in Law

12.2.1 During Construction Period, the impact of increase/decrease in the cost of the Project on the Transmission Charges shall be governed by the formula given in Schedule 9 of this Agreement.

12.2.2 During the Operation Period:

During the operation period, if as a result of Change in Law, the TSP suffers or is benefited from a change in costs or revenue, the aggregate financial effect of which exceeds 0.30% (zero point three percent) of the Annual Transmission Charges in aggregate for a Contract Year, the TSP may notify so to the Nodal Agency and propose amendments to this Agreement so as to place the TSP in the same financial position as it would have enjoyed had there been no such Change in Law resulting in change in costs or revenue as aforesaid.

12.2.3 For any claims made under Articles 12.2.1 and 12.2.2 above, the TSP shall provide to the Nodal Agency documentary proof of such increase / decrease in cost of the Project / revenue for establishing the impact of such Change in Law.

In cases where Change in Law results in decrease of cost and it comes to the notice of Nodal Agency that TSP has not informed Nodal Agency about such decrease in cost, Nodal Agency may initiate appropriate claim.



Central Transmission Utility of India Limited

51



Kallam Transco Limited

1 April 2024

12.3 Notification of Change in Law:

- 12.3.1 If the TSP is affected by a Change in Law in accordance with Article 12.1 and wishes to claim relief for such Change in Law under this Article 12, it shall give notice to Nodal Agency of such Change in Law as soon as reasonably practicable after becoming aware of the same.
- 12.3.2 The TSP shall also be obliged to serve a notice to the Nodal Agency even when it is beneficially affected by a Change in Law.
- 12.3.3 Any notice served pursuant to Articles 12.3.1 and 12.3.2 shall provide, amongst other things, precise details of the Change in Law and its estimated impact on the TSP.

12.4 Payment on account of Change in Law

- 12.4.1 The payment for Change in Law shall be through a separate Bill. However, in case of any change in Monthly Transmission Charges by reason of Change in Law, as determined in accordance with this Agreement, the Bills to be raised by the Nodal Agency after such change in Transmission Charges shall appropriately reflect the changed Monthly Transmission Charges.



ARTICLE: 13**13 EVENTS OF DEFAULT AND TERMINATION****13.1 TSP's Event of Default**

The occurrence and continuation of any of the following events shall constitute a TSP Event of Default, unless any such TSP Event of Default occurs as a result of any non-fulfilment of its obligations as prescribed under this Agreement by the Nodal Agency or a Force Majeure Event:

- a. After having taken up the construction of the Project, the abandonment by the TSP or the TSP's Contractors of the construction of the Project for a continuous period of two (2) months and such default is not rectified within thirty (30) days from the receipt of notice from the Nodal Agency in this regard;
- b. The failure to commission any Element of the Project by the date falling six (6) months after its Scheduled COD unless extended by Nodal Agency as per provisions of this Agreement;
- c. If the TSP:
 - i. assigns, mortgages or charges or purports to assign, mortgage or charge any of its assets or rights related to the Project in contravention of the provisions of this Agreement; or
 - ii. transfers or novates any of its obligations pursuant to this Agreement, in a manner contrary to the provisions of this Agreement;

Except where such transfer is in pursuance of a Law and

- it does not affect the ability of the transferee to perform, and such transferee has the financial and technical capability to perform, its obligations under this Agreement;
- is to a transferee who assumes such obligations under the Project and this Agreement remains effective with respect to the transferee;

- d. If:
- i. The TSP becomes voluntarily or involuntarily the subject of any bankruptcy or insolvency or winding up proceedings and such proceedings remain uncontested for a period of thirty (30) days; or
 - ii. any winding up or bankruptcy or insolvency order is passed against the TSP; or
 - iii. the TSP goes into liquidation or dissolution or a receiver or any similar officer is appointed over all or substantially all of its assets or official liquidator is appointed to manage its affairs, pursuant to Law,

Provided that a dissolution or liquidation of the TSP will not be a TSP's Event of Default, where such dissolution or liquidation of the TSP is for the purpose of a merger, consolidation or reorganization with the prior approval of the Commission as per the provisions of Central Electricity Regulatory Commission (Procedure, terms and Conditions for grant of Transmission License and other related matters) Regulations, 2006 or as amended from time to time; or

- e. Failure on the part of the TSP to comply with the provisions of Article 19.1 of this Agreement; or
- f. the TSP repudiates this Agreement and does not rectify such breach even within a period of thirty (30) days from a notice from the Nodal Agency in this regard; or
- g. after Commercial Operation Date of the Project, the TSP fails to achieve monthly Target Availability of 98%, for a period of six (6) consecutive months or within a non-consecutive period of six (6) months within any continuous aggregate period of eighteen(18) months except where the Availability is affected by Force Majeure Events as per Article 11; or
- h. any of the representations and warranties made by the TSP in Article 17 of this Agreement being found to be untrue or inaccurate. Further, in addition to the above, any of the undertakings submitted by the Selected Bidder at the time of submission of the Bid being found to be breached or inaccurate, including but not limited to undertakings from its



Parent Company / Affiliates related to the minimum equity obligation; or

- i. the TSP fails to complete / fulfil all the activities / conditions within the specified period as per Article 3; or
- j. except for the reasons solely attributable to Nodal Agency, the TSP is in material breach of any of its obligations under this Agreement and such material breach is not rectified by the TSP within thirty (30) days of receipt of notice in this regard from the Nodal Agency; or
- k. deleted.

13.2 Termination Procedure for TSP Event of Default

- a. Upon the occurrence and continuance of any TSP's Event of Default under Article 13.1 the Nodal Agency may serve notice on the TSP, with a copy to the CEA and the Lenders' Representative, of their intention to terminate this Agreement (a "Nodal Agency's Preliminary Termination Notice"), which shall specify in reasonable detail, the circumstances giving rise to such Nodal Agency's Preliminary Termination Notice.
- b. Following the issue of a Nodal Agency's Preliminary Termination Notice, the Consultation Period shall apply and would be for the Parties to discuss as to what steps shall be taken with a view to mitigate the consequences of the relevant Event of Default having regard to all the circumstances.
- c. During the Consultation Period, the Parties shall, save as otherwise provided in this Agreement, continue to perform their respective obligations/ roles under this Agreement, and the TSP shall not remove any material, equipment or any part of the Project, without prior consent of the Nodal Agency.

Following the expiry of the Consultation Period, unless the Parties shall have otherwise agreed to the contrary or the circumstances giving rise to Nodal Agency's Preliminary Termination Notice shall have ceased to exist or shall have been remedied, this Agreement may be terminated by the Nodal Agency by giving a Termination Notice to the TSP, in writing, of at least seven (7) days, with a copy to CEA and the Lenders' Representative in order to enable the Lenders to exercise right of substitution in accordance with Article 15.3 of this Agreement.



Central Transmission Utility of India Limited

55



Kallam Transco Limited

1 April 2024

Further, the Nodal Agency may also initiate proceedings to blacklist the TSP & its Affiliates from participation in any RFP issued by BPCs for a period of 5 years.

13.3 Procedure for Nodal Agency's non-fulfilment of Role

- a. Upon the Nodal Agency not being able to fulfil its role under Article 4.2, the TSP may serve notice on the Nodal Agency, with a copy to CEA and the Lenders' Representative (a "TSP's Preliminary Notice"), which notice shall specify in reasonable detail the circumstances giving rise to such non-fulfilment of role by the Nodal Agency.
- b. Following the issue of a TSP's Preliminary Notice, the Consultation Period shall apply.
- c. The Consultation Period would be for the Parties to discuss as to what steps shall be taken with a view to mitigate the consequences of the relevant non-fulfilment of role by the Nodal Agency including giving time extension to TSP, having regard to all the circumstances.
- d. During the Consultation Period, both Parties shall, save as otherwise provided in this Agreement, continue to perform their respective obligations/ roles under this Agreement.

13.4 Termination due to Force Majeure

- 13.4.1 In case the Parties could not reach an agreement pursuant to Articles 3.3.4 and 4.4.2 of this Agreement and the Force Majeure Event or its effects continue to be present, the Nodal Agency shall have the right to cause termination of the Agreement. In case of such termination, the Contract Performance Guarantee shall be returned to the TSP as per the provisions of Article 6.5.1.



13.4.2 In case of termination of this Agreement, the TSP shall provide to the Nodal Agency the full names and addresses of its Contractors as well as complete designs, design drawings, manufacturing drawings, material specifications and technical information, as required by the Nodal Agency within thirty (30) days of Termination Notice.

13.5 Termination or amendment due to non-requirement of any Element or Project during construction

13.5.1 In case any Element or Project, which is under construction, is no longer required due to any reason whatsoever, the Nodal Agency may issue a notice to this effect to the TSP.

13.5.2 Nodal agency may also issue notice to the TSP seeking their response to the proposed termination/ amendment (as the case may be) of the Agreement. The Nodal Agency shall issue copy of such notice to Lenders. In the notice, Nodal Agency shall also include an assessment of the physical progress made by TSP in the Element/ Project (as the case may be) that is no longer required.

13.5.3 The TSP shall neither carry out further investment nor carry out any work on the Element/ Project (as the case may be) that is no longer required after delivery of the notice.

13.5.4 After taking into account the comments of the TSP, the Nodal Agency may terminate the Agreement or amend it if both Parties agree to the amendment.

13.6 Revocation of the Transmission License

13.6.1 The Commission may, as per the provisions of the Electricity Act, 2003, revoke the Transmission License of the ISTS Licensee. Further, in such a case, the Agreement shall be deemed to have been terminated.

13.7 Termination Payment

13.7.1 If Agreement is terminated on account of Force Majeure Events, non-requirement of any Element or Project during Construction, Nodal Agency's non-fulfilment of Role & TSP's Event of Default, the TSP shall be entitled for Termination Payment equivalent to valuation of Project Assets. Upon payment, the Nodal Agency shall take over the Project Assets.

ARTICLE: 14**14 LIABILITY AND INDEMNIFICATION****14.1 Indemnity**

14.1.1 The TSP shall indemnify, defend and hold the Nodal Agency harmless against:

- (a) any and all third party claims, actions, suits or proceedings against the Nodal Agency for any loss of or damage to property of such third party, or death or injury to such third party, arising out of a breach by the TSP of any of its obligations under this Agreement, except to the extent that any such claim, action, suit or proceeding has arisen due to a negligent act or omission, breach of this Agreement or non-fulfilment of statutory duty on the part of Nodal Agency; and
- (b) any and all losses, damages, costs and expenses including legal costs, fines, penalties and interest actually suffered or incurred by the Nodal Agency from third party claims arising by reason of:
 - i. a breach by the TSP of any of its obligations under this Agreement, (provided that this Article 14 shall not apply to such breaches by the TSP, for which specific remedies have been provided for under this Agreement) except to the extent that any such losses, damages, costs and expenses including legal costs, fines, penalties and interest (together to constitute "Indemnifiable Losses") has arisen due to a negligent act or omission, breach of this Agreement or non-fulfilment of statutory duty on the part of the Nodal Agency, or
 - ii. any of the representations and warranties of the TSP under this Agreement being found to be inaccurate or untrue.

14.1.2 The Nodal Agency shall, in accordance with the Regulations framed by CERC in this regard, indemnify, defend and hold the TSP harmless against:

- (a) any and all third party claims, actions, suits or proceedings against the TSP, for any loss of or damage to property of such third party, or death or injury to such third party, arising out of any material breach by the Nodal Agency of any of their roles under this



Agreement, except to the extent that any such claim, action, suit or proceeding has arisen due to a negligent act or omission, breach of this Agreement or breach of statutory duty on the part of the TSP, its Contractors, servants or agents; and

- (b) any and all losses, damages, costs and expenses including legal costs, fines, penalties and interest ('Indemnifiable Losses') actually suffered or incurred by the TSP from third party claims arising by reason of:
- i. any material breach by the Nodal Agency of any of its roles under this Agreement (provided that, this Article 14 shall not apply to such breaches by the Nodal Agency, for which specific remedies have been provided for under this Agreement), except to the extent that any such Indemnifiable Losses have arisen due to a negligent act or omission, breach of this Agreement or breach of statutory duty on the part of the TSP, its Contractors, servants or agents or
 - ii. any of the representations and warranties of the Nodal Agency under this Agreement being found to be inaccurate or untrue.

14.2 Patent Indemnity:

14.2.1

- (a) The TSP shall, subject to the Nodal Agency's compliance with Article 14.2.1 (b), indemnify and hold harmless the Nodal Agency and its employees and officers from and against any and all suits, actions or administrative proceedings, claims, demands, losses, damages, costs, and expenses of whatsoever nature, including attorney's fees and expenses, which the Nodal Agency may suffer as a result of any infringement or alleged infringement of any patent, utility model, registered design, trademark, copyright or other intellectual property right registered or otherwise existing at the date of the Agreement by reason of the setting up of the Project by the TSP.

Such indemnity shall not cover any use of the Project or any part thereof other than for the purpose indicated by or to be reasonably inferred from the Agreement, any infringement resulting from the misuse of the Project or any part thereof, or any products produced in association or combination with any other equipment, plant or

materials not supplied by the TSP, pursuant to the Agreement.

- (b) If any proceedings are brought or any claim is made against the Nodal Agency arising out of the matters referred to in Article 14.2.1(a), the Nodal Agency shall promptly give the TSP a notice thereof, and the TSP shall at its own expense take necessary steps and attend such proceedings or claim and any negotiations for the settlement of any such proceedings or claim. The TSP shall promptly notify the Nodal Agency of all actions taken in such proceedings or claims.
- (c) If the TSP fails to notify the Nodal Agency within twenty-eight (28) days after receipt of such notice from the Nodal Agency under Article 14.2.1(b) above, that it intends to attend any such proceedings or claim, then the Nodal Agency shall be free to attend the same on their own behalf at the cost of the TSP. Unless the TSP has so failed to notify the Nodal Agency within the twenty eight (28) days period, the Nodal Agency shall make no admission that may be prejudicial to the defence of any such proceedings or claims.
- (d) The Nodal Agency shall, at the TSP's request, afford all available assistance to the TSP in attending to such proceedings or claim, and shall be reimbursed by the TSP for all reasonable expenses incurred in so doing.

14.2.2

- (a) The Nodal Agency, in accordance with the Regulations framed by CERC in this regard, subject to the TSP's compliance with Article 14.2.2(b) shall indemnify and hold harmless the TSP and its employees, officers from and against any and all suits, actions or administrative proceedings, claims, demands, losses, damages, costs and expenses of whatsoever nature, including attorney's fees and expenses, which the TSP may suffer as a result of any infringement or alleged infringement of any patent, utility model, registered design, trademark, copyright or other intellectual property right registered or otherwise existing at the date of the Agreement by reason of the setting up of the Project by the TSP.
- (b) If any proceedings are brought or any claim is made against the TSP arising out of the matters referred to in Article 14.2.2 (a) the TSP shall promptly give the Nodal Agency a notice thereof, and the

Nodal Agency shall at its own expense take necessary steps and attend such proceedings or claim and any negotiations for the settlement of any such proceedings or claim. The Nodal Agency shall promptly notify the TSP of all actions taken in such proceedings or claims.

- (c) If the Nodal Agency fails to notify the TSP within twenty-eight (28) days after receipt of such notice from the TSP under Article 14.2.2(b) above, that it intends to attend any such proceedings or claim, then the TSP shall be free to attend the same on its own behalf at the cost of the Nodal Agency. Unless the Nodal Agency has so failed to notify the TSP within the twenty (28) days period, the TSP shall make no admission that may be prejudicial to the defence of any such proceedings or claim.
- (d) The TSP shall, at the Nodal Agency request, afford all available assistance to the Nodal Agency in attending to such proceedings or claim, and shall be reimbursed by the Nodal Agency for all reasonable expenses incurred in so doing.

14.3 Monetary Limitation of liability

- 14.3.1 A Party ("Indemnifying Party") shall be liable to indemnify the other Party ("Indemnified Party") under this Article 14 for any indemnity claims made in a Contract Year only up to an amount of Rs. 0.20 Crore (Rupees Twenty Lakh Only).

14.4 Procedure for claiming indemnity

- 14.4.1 Where the Indemnified Party is entitled to indemnification from the Indemnifying Party pursuant to Articles 14.1 or 14.2 the Indemnified Party shall promptly notify the Indemnifying Party of such claim, proceeding, action or suit referred to in Articles 14.1 or 14.2 in respect of which it is entitled to be indemnified. Such notice shall be given as soon as reasonably practicable after the Indemnified Party becomes aware of such claim, proceeding, action or suit. The Indemnifying Party shall be liable to settle the indemnification claim within thirty (30) days of receipt of the above notice.

Provided however that, if:

- i. the Parties choose to contest, defend or litigate such claim, action, suit or proceedings in accordance with Article 14.4.3 below, and



Central Transmission Utility of India Limited

61



Kallan Transco Limited

1 April 2024

- ii. the claim amount is not required to be paid/deposited to such third party pending the resolution of the Dispute,

the Indemnifying Party shall become liable to pay the claim amount to the Indemnified Party or to the third party, as the case may be, promptly following the resolution of the Dispute, if such Dispute is not settled in favour of the Indemnified Party.

- 14.4.2 The Indemnified Party may contest, defend and litigate a claim, action, suit or proceeding for which it is entitled to be indemnified under Articles 14.1 or 14.2 and the Indemnifying Party shall reimburse to the Indemnified Party all reasonable costs and expenses incurred by the Indemnified Party. However, such Indemnified Party shall not settle or compromise such claim, action, suit or proceedings without first getting the consent of the Indemnifying Party, which consent shall not be unreasonably withheld or delayed.

- 14.4.3 An Indemnifying Party may, at its own expense, assume control of the defence of any proceedings brought against the Indemnified Party if it acknowledges its obligation to indemnify such Indemnified Party, gives such Indemnified Party prompt notice of its intention to assume control of the defence, and employs an independent legal counsel at its own cost that is reasonably satisfactory to the Indemnified Party.

14.5 Limitation on Liability

- 14.5.1 Except as expressly provided in this Agreement, neither the TSP nor the Nodal Agency nor their respective officers, directors, agents, employees or Affiliates (including, officers, directors, agents or employees of such Affiliates), shall be liable or responsible to the other Party or its Affiliates including its officers, directors, agents, employees, successors, insurers or permitted assigns for incidental, indirect or consequential, punitive or exemplary damages, connected with or resulting from performance or non-performance of this Agreement, or anything done in connection herewith, including claims in the nature of lost revenues, income or profits (other than payments expressly required and properly due under this Agreement), any increased expense of, reduction in or loss of transmission capacity or equipment used therefore, irrespective of whether such claims are based upon breach of warranty, tort (including negligence, whether of the Nodal Agency, the TSP or others), strict liability, contract, breach of statutory duty, operation of law or otherwise.

14.5.2 The Nodal Agency shall have no recourse against any officer, director or shareholder of the TSP or any Affiliate of the TSP or any of its officers, directors or shareholders for such claims excluded under this Article. The TSP shall also have no recourse against any officer, director or shareholder of the Nodal Agency, or any Affiliate of the Nodal Agency or any of its officers, directors or shareholders for such claims excluded under this Article.

14.6 Duty to Mitigate

The party entitled to the benefit of an indemnity under this Article 14 shall take all reasonable measures to mitigate any loss or damage which has occurred. If the Party fails to take such measures, the other Party's liabilities shall be correspondingly reduced.



Central Transmission Utility of India Limited

63



Kallam Transco Limited

1 April 2024

ARTICLE: 15**15 ASSIGNMENTS AND CHARGES****15.1 Assignments:**

15.1.1 This Agreement shall be binding upon, and inure to the benefit of the Parties and their respective successors and permitted assigns. This Agreement shall not be assigned by any Party, except as provided in Article 15.3.

15.2 Permitted Charges:

15.2.1 Neither Party shall create or permit to subsist any encumbrance over all or any of its rights and benefits under this Agreement.

15.2.2 However, the TSP may create any encumbrance over all or part of the receivables, or the Project Assets of the Project in favour of the Lenders or the Lenders' Representative on their behalf, as security for amounts payable under the Financing Agreements and any other amounts agreed by the Parties.

Provided that:

- i. the Lenders or the Lenders' Representative on their behalf shall have entered into the Financing Agreements and agreed in writing to the provisions of this Agreement; and
- ii. any encumbrance granted by the TSP in accordance with this Article 15.2.2 shall contain provisions pursuant to which the Lenders or the Lender's Representative on their behalf agrees unconditionally with the TSP to release from such encumbrances upon payment by the TSP to the Lenders of all amounts due under the Financing Agreements.

15.2.3 Article 15.2.1 does not apply to:

- a. liens arising by operation of law (or by an agreement evidencing the same) in the ordinary course of the TSP developing and operating the Project;
- b. pledges of goods, the related documents of title and / or other related documents, arising or created in the ordinary course of the TSP developing and operating the Project; or

- c. security arising out of retention of title provisions in relation to goods acquired in the ordinary course of the TSP developing and operating the Project.

15.3 Substitution Rights of the Lenders

15.3.1 The TSP would need to operate and maintain the Project under the provisions of this Agreement and cannot assign the Transmission License or transfer the Project or part thereof to any person by sale, lease, exchange or otherwise, without the prior approval of the Nodal Agency.

15.3.2 However, in the case of default by the TSP in debt repayments or in the case of default by the TSP as per Article 13 of this Agreement during the debt repayments, the Commission may, on an application from the Lenders, assign the Transmission License to the nominee of the Lenders subject to the fulfilment of the qualification requirements and provisions of the Central Electricity Regulatory Commission (Procedure, terms and Conditions for grant of Transmission License and other related matters) Regulations, 2006 and as amended from time to time.



ARTICLE: 16**16 GOVERNING LAW AND DISPUTE RESOLUTION****16.1 Governing Law:**

This Agreement shall be governed by and construed in accordance with the Laws of India. Any legal proceedings in respect of any matters, claims or disputes under this Agreement shall be under the jurisdiction of appropriate courts in Delhi.

16.2 Amicable Settlement:

16.2.1 Either Party is entitled to raise any claim, dispute or difference of whatever nature arising under, out of or in connection with this Agreement, including its existence or validity or termination or whether during the execution of the Project or after its completion and whether prior to or after the abandonment of the Project or termination or breach of the Agreement by giving a written notice to the other Party, which shall contain:

- (i) a description of the Dispute;
- (ii) the grounds for such Dispute; and
- (iii) all written material in support of its claim.

16.2.2 The other Party shall, within thirty (30) days of issue of notice issued under Article 16.2.1, furnish:

- (i) counter-claim and defences, if any, regarding the Dispute; and
- (ii) all written material in support of its defences and counter-claim.

16.2.3 Within thirty (30) days of issue of notice by the Party pursuant to Article 16.2.1, if the other Party does not furnish any counter claim or defense under Article 16.2.2, or thirty (30) days from the date of furnishing counter claims or defence by the other Party, both the Parties to the Dispute shall meet to settle such Dispute amicably. If the Parties fail to resolve the Dispute amicably within thirty (30) days from the later of the dates mentioned in this Article 16.2.3, the Dispute shall be referred for dispute resolution in accordance with Article 16.3.



16.3 Dispute Resolution:

All Disputes shall be adjudicated by the Commission.

16.4 Parties to Perform Obligations:

Notwithstanding the existence of any Dispute and difference referred to the Commission as provided in Article 16.3 and save as the Commission may otherwise direct by a final or interim order, the Parties hereto shall continue to perform their respective obligations/ roles (which are not in dispute) under this Agreement.

ARTICLE: 17**17 REPRESENTATION AND WARRANTIES****17.1 Representation and warranties of the Nodal Agency**

17.1.1 The Nodal Agency hereby represents and warrants to and agrees with the TSP as follows and acknowledges and confirms that the TSP is relying on such representations and warranties in connection with the transactions described in this Agreement:

- a. It has all requisite powers and authority to execute and consummate this Agreement;
- b. This Agreement is enforceable against the Nodal Agency in accordance with its terms;
- c. The consummation of the transactions contemplated by this Agreement on the part of Nodal Agency will not violate any provision of nor constitute a default under, nor give rise to a power to cancel any charter, mortgage, deed of trust or lien, lease, agreement, license, permit, evidence of indebtedness, restriction, or other contract to which the Nodal Agency is a Party or to which the Nodal Agency is bound, which violation, default or power has not been waived;

17.2 Representation and Warranties of the TSP:

17.2.1 The TSP hereby represents and warrants to and agrees with the Nodal Agency as follows and acknowledges and confirms that the Nodal Agency is relying on such representations and warranties in connection with the transactions described in this Agreement:

- a. It has all requisite powers and has been duly authorized to execute and consummate this Agreement;
- b. This Agreement is enforceable against it, in accordance with its terms;
- c. The consummation of the transactions contemplated by this Agreement on the part of the TSP will not violate any provision of nor constitute a default under, nor give rise to a power to cancel any charter, mortgage, deed of trust or lien, lease, agreement, license, permit, evidence of indebtedness, restriction, or other contract to which the TSP is a Party or to which the TSP is bound which violation, default or power has not been waived;



Transmission Service Agreement

- d. The TSP is not insolvent and no insolvency proceedings have been instituted, nor threatened or pending by or against the TSP;
- e. There are no actions, suits, claims, proceedings or investigations pending or, to the best of the TSP's knowledge, threatened in writing against the TSP at law, in equity, or otherwise, and whether civil or criminal in nature, before or by, any court, commission, arbitrator or governmental agency or authority, and there are no outstanding judgments, decrees or orders of any such courts, commission, arbitrator or governmental agencies or authorities, which materially adversely affect its ability to execute the Project or to comply with its obligations under this Agreement.

17.2.2 The TSP makes all the representations and warranties above to be valid as on the Effective Date of this Agreement.



ARTICLE: 18**18 INDEPENDENT ENGINEER****18.1 Appointment of Independent Engineer**

The Nodal Agency shall appoint an agency/ company as Independent Engineer as per framework provided in the Guidelines for Encouraging Competition in Development of Transmission Projects for selection of Independent Engineer.

18.2 Roles and functions of Independent Engineer

The role and functions of the Independent Engineer shall include the following:

- a. Progress Monitoring as required under this Agreement;
- b. Ensuring Quality as required under this Agreement;
- c. determining, as required under the Agreement, the costs of any works or services and/or their reasonableness during construction phase;
- d. determining, as required under the Agreement, the period or any extension thereof, for performing any duty or obligation during construction phase;
- e. determining, as required under the Agreement, the valuation of the Project Assets.
- f. Assisting the Parties in resolution of Disputes and
- g. Undertaking all other duties and functions in accordance with the Agreement.

18.3 Remuneration of Independent Engineer

The fee and charges of the Independent Engineer shall be paid by the Nodal Agency as per terms & conditions of appointment.

18.4 Termination of appointment

18.4.1 The Nodal Agency may, in its discretion, terminate the appointment of the Independent Engineer at any time, but only after appointment of another Independent Engineer.



18.4.2 If the TSP has reason to believe that the Independent Engineer is not discharging its duties and functions in a fair, efficient and diligent manner, it may make a written representation to the Nodal Agency and seek termination of the appointment of the Independent Engineer. Upon receipt of such representation, the Nodal Agency shall hold a tripartite meeting with the TSP and Independent Engineer for an amicable resolution, and the decision of Nodal agency is final. In the event that the appointment of the Independent Engineer is terminated hereunder, the Nodal Agency shall appoint forthwith another Independent Engineer.

18.5 Authorised signatories

The Nodal Agency shall require the Independent Engineer to designate and notify to the Nodal Agency up to 2 (two) persons employed in its firm to sign for and on behalf of the Independent Engineer, and any communication or document required to be signed by the Independent Engineer shall be valid and effective only if signed by any of the designated persons; provided that the Independent Engineer may, by notice in writing, substitute any of the designated persons by any of its employees.

Central Transmission Utility of India Limited



71

Kallam Transco Limited



1 April 2024

ARTICLE: 19**19 MISCELLANEOUS PROVISIONS****19.1 Equity Lock-in Commitment:**

19.1.1 The aggregate equity share holding of the Selected Bidder in the issued and paid up equity share capital of Kallam Transco Limited shall not be less than Fifty-one percent (51%) up to a period of one (1) year after COD of the Project.

Provided that, in case the Lead Member or Bidding Company is holding equity through Affiliate/s, Ultimate Parent Company or Parent Company, such restriction as specified above shall apply to such entities.

Provided further, that in case the Selected Bidder is a Bidding Consortium, the Lead Member shall continue to hold equity of at least twenty-six percent (26%) upto a period of one (1) year after COD of the Project and any Member of such Bidding Consortium shall be allowed to divest its equity as long as the other remaining Members (which shall always include the Lead Member) hold the minimum equity specified above.

19.1.2 If equity is held by the Affiliates, Parent Company or Ultimate Parent Company of the Selected Bidder, then, subject to the second proviso to Article 19.1.1, such Affiliate, Parent Company or Ultimate Parent Company shall be eligible to transfer its shareholding in Kallam Transco Limited to another Affiliate or to the Parent Company / Ultimate Parent Company of the Selected Bidder. If any such shareholding entity, qualifying as an Affiliate / Parent Company / Ultimate Parent Company, is likely to cease to meet the criteria to qualify as an Affiliate / Parent Company / Ultimate Parent Company, the shares held by such entity shall be transferred to another Affiliate / Parent Company / Ultimate Parent Company of the Selected Bidder.

19.1.3 Subject to Article 19.1.1, all transfer(s) of shareholding of Kallam Transco Limited by any of the entities referred to in Article 19.1.1 and 19.1.2 above, shall be after prior written intimation to the Nodal Agency.

19.1.4 For computation of effective Equity holding, the Equity holding of the Selected Bidder or its Ultimate Parent Company in such Affiliate(s) or Parent Company and the equity holding of such Affiliate(s) or Ultimate Parent Company in Kallam Transco Limited shall be computed in accordance with the example given below:



If the Parent Company or the Ultimate Parent Company of the Selected Bidder A directly holds thirty percent (30%) of the equity in Kallam Transco Limited then holding of Selected Bidder A in Kallam Transco Limited shall be thirty percent (30%);

If Selected Bidder A holds thirty percent (30%) equity of the Affiliate and the Affiliate holds fifty percent (50%) equity in Kallam Transco Limited, then, for the purposes of ascertaining the minimum equity/equity lock-in requirements specified above, the effective holding of Bidder A in Kallam Transco Limited shall be fifteen percent (15%), (i.e., 30% x 50%)

19.1.5 The provisions as contained in this Article 19.1 shall override the terms of the consortium agreement submitted as part of the Bid.

19.1.6 The TSP shall be responsible to report to Nodal Agency, within thirty (30) days from the occurrence of any event that would result in any change in its equity holding structure from that which existed as on the date of signing of the Share Purchase Agreement. In such cases, the Nodal Agency would reserve the right to ascertain the equity holding structure and to call for all such required documents / information / clarifications as may be required.

19.2 Commitment of maintaining Qualification Requirement

19.2.1 The Selected Bidder will be required to continue to maintain compliance with the Qualification Requirements, as stipulated in RFP Document, till the COD of the Project. Where the Technically Evaluated Entity and/or the Financially Evaluated Entity is not the Bidding Company or a Member in a Bidding Consortium, as the case may be, the Bidding Company or Member shall continue to be an Affiliate of the Technically Evaluated Entity and/or Financially Evaluated Entity till the COD of the Project.

19.2.2 Failure to comply with the aforesaid provisions shall be dealt in the same manner as TSP's Event of Default as under Article 13 of this Agreement.

19.3 Language:

19.3.1 All agreements, correspondence and communications between the Parties relating to this Agreement and all other documentation to be prepared and supplied under the Agreement shall be written in English, and the Agreement shall be construed and interpreted in accordance with English language.

19.3.2 If any of the agreements, correspondence, communications or documents are prepared in any language other than English, the English



translation of such agreements, correspondence, communications or documents shall prevail in matters of interpretation.

19.4 Affirmation

The TSP and the Nodal Agency, each affirm that:

1. neither it nor its respective directors, employees, or agents has paid or undertaken to pay or shall in the future pay any unlawful commission, bribe, pay-off or kick-back; and
2. it has not in any other manner paid any sums, whether in Indian currency or foreign currency and whether in India or abroad to the other Party to procure this Agreement, and the TSP and the Nodal Agency hereby undertake not to engage in any similar acts during the Term of Agreement.

19.5 Severability

The invalidity or enforceability, for any reason, of any part of this Agreement shall not prejudice or affect the validity or enforceability of the remainder of this Agreement, unless the part held invalid or unenforceable is fundamental to this Agreement.

19.6 Counterparts

This Agreement may be executed in one or more counterparts, each of which shall be deemed an original and all of which collectively shall be deemed one and the same Agreement.

19.7 Breach of Obligations/ Roles

The Parties acknowledge that a breach of any of the obligations/ roles contained herein would result in injuries. The Parties further acknowledge that the amount of the liquidated damages or the method of calculating the liquidated damages specified in this Agreement is a genuine and reasonable pre-estimate of the damages that may be suffered by the non-defaulting Party in each case specified under this Agreement.

19.8 Restriction of Shareholders / Owners Liability

- 19.8.1 Parties expressly agree and acknowledge that none of the shareholders of the Parties hereto shall be liable to the other Parties for any of the contractual obligations of the concerned Party under this Agreement.



19.8.2 Further, the financial liabilities of the shareholder(s) of each Party to this Agreement shall be restricted to the extent provided in the Indian Companies Act, 1956 / Companies Act, 2013 (as the case may be).

19.9 Taxes and Duties:

19.9.1 The TSP shall bear and promptly pay all statutory taxes, duties, levies and cess, assessed/levied on the TSP, its Contractors or their employees that are required to be paid by the TSP as per the Law in relation to the execution of the Project and for providing Transmission Service as per the terms of this Agreement.

19.9.2 The Nodal Agency shall be indemnified and held harmless by the TSP against any claims that may be made against the Nodal Agency in relation to the matters set out in Article 19.9.1.

19.9.3 The Nodal Agency shall not be liable for any payment of, taxes, duties, levies, cess whatsoever for discharging any obligation of the TSP by the Nodal Agency on behalf of TSP or its personnel, provided the TSP has consented in writing to the Nodal Agency for such work, for which consent shall not be unreasonably withheld.

19.10 No Consequential or Indirect Losses

The liability of the TSP shall be limited to that explicitly provided in this Agreement.

Provided that, notwithstanding anything contained in this Agreement, under no event shall the Nodal Agency or the TSP claim from one another any indirect or consequential losses or damages.

19.11 Discretion:

Except where this Agreement expressly requires a Party to act fairly or reasonably, a Party may exercise any discretion given to it under this Agreement in any way it deems fit.

19.12 Confidentiality

19.12.1 The Parties undertake to hold in confidence this Agreement and RFP Project Documents and not to disclose the terms and conditions of the transaction contemplated hereby to third parties, except:

- (a) to their professional advisors;
- (b) to their officers, contractors, employees, agents or representatives, financiers, who need to have access to such

information for the proper performance of their activities; or

- (c) disclosures required under Law,
without the prior written consent of the other Parties.

Provided that, the TSP agrees and acknowledges that the Nodal Agency, may, at any time, disclose the terms and conditions of the Agreement and the RFP Project Documents to any person, to the extent stipulated under the Law and the Competitive Bidding Guidelines.

19.13 Order of priority in application:

Save as provided in Article 2.5, in case of inconsistencies between the terms and conditions stipulated in Transmission License issued by the Commission to the TSP, agreement(s) executed between the Parties, applicable Law including rules and regulations framed thereunder, the order of priority as between them shall be the order in which they are placed below:

- terms and conditions of Transmission License;
- applicable Law, rules and regulations framed thereunder;
- this Agreement;
- Agreement(s), if any, under Sharing Regulations.

19.14 Independent Entity:

19.14.1 The TSP shall be an independent entity performing its obligations pursuant to the Agreement.

19.14.2 Subject to the provisions of the Agreement, the TSP shall be solely responsible for the manner in which its obligations under this Agreement are to be performed. All employees and representatives of the TSP or Contractors engaged by the TSP in connection with the performance of the Agreement shall be under the complete control of the TSP and shall not be deemed to be employees, representatives, Contractors of the Nodal Agency and nothing contained in the Agreement or in any agreement or contract awarded by the TSP shall be construed to create any contractual relationship between any such employees, representatives or Contractors and the Nodal Agency.



19.15 Amendments:

19.15.1 This Agreement may only be amended or supplemented by a written agreement between the Parties.

19.16 Waiver:

19.16.1 No waiver by either Party of any default or breach by the other Party in the performance of any of the provisions of this Agreement shall be effective unless in writing duly executed by an authorised representative of such Party.

19.16.2 Neither the failure by either Party to insist on any occasion upon the performance of the terms, conditions and provisions of this Agreement nor time or other indulgence granted by one Party to the other Parties shall act as a waiver of such breach or acceptance of any variation or the relinquishment of any such right or any other right under this Agreement, which shall remain in full force and effect.

19.17 Relationship of the Parties:

This Agreement shall not be interpreted or construed to create an association, joint venture, or partnership or agency or any such other relationship between the Parties or to impose any partnership obligation or liability upon either Party and neither Party shall have any right, power or authority to enter into any agreement or undertaking for, or act on behalf of, or to act as or be an agent or representative of, or to otherwise bind, the other Party.

19.18 Entirety:

19.18.1 This Agreement along with its sections, schedules and appendices is intended by the Parties as the final expression of their agreement and is intended also as a complete and exclusive statement of the terms of their agreement.

19.18.2 Except as provided in this Agreement, all prior written or oral understandings, offers or other communications of every kind pertaining to this Agreement or the provision of Transmission Service under this Agreement to the Nodal Agency by the TSP shall stand superseded and abrogated.

19.19 Notices:

19.19.1 All notices or other communications which are required to be given under this Agreement shall be in writing and in the English language

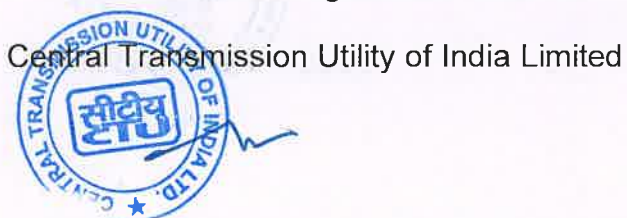

Transmission Service Agreement

- 19.19.2 If to the TSP, all notices or communications must be delivered personally or by registered post or facsimile or any other mode duly acknowledged to the addressee below:

Address : UNIT - 101, WINDSOR, CST ROAD, VIDYANAGARI MARG,
KALINA, SANTACRUZ EAST MUMBAI - 400098
Attention : ADITYA KISLAY
Email : ADITYA - KISLAY @ INDI GRID . COM
Fax. No. : -
Telephone No. : 9999312834.

- 19.19.3 If to the Nodal Agency, all notices or communications must be delivered personally or by registered post or facsimile or any other mode duly acknowledged to the addresses below:

(i) **CENTRAL TRANSMISSION UTILITY OF INDIA LIMITED**

Address : Plot No.2, Sector – 29, Gurugram, Haryana-
122001, India
Attention : Mr. Atul Kumar Agarwal, CGM
Email : atul_ag@powergrid.in
Fax. No. :
Telephone No. : 9910378059

- 19.19.4 All notices or communications given by facsimile shall be confirmed by sending a copy of the same via post office in an envelope properly addressed to the appropriate Party for delivery by registered mail. All notices shall be deemed validly delivered upon receipt evidenced by an acknowledgement of the recipient, unless the Party delivering the notice can prove in case of delivery through the registered post that the recipient refused to acknowledge the receipt of the notice despite efforts of the postal authorities.

- 19.19.5 Any Party may by notice of at least fifteen (15) days to the other Party change the address and/or addresses to which such notices and communications to it are to be delivered or mailed.

19.20 Fraudulent and Corrupt Practices

- 19.20.1 The TSP and its respective officers, employees, agents and advisers shall observe the highest standard of ethics during the subsistence of this Agreement. Notwithstanding anything to the contrary contained in the Agreement, the Nodal Agency may terminate the Agreement without being liable in any manner whatsoever to the TSP, if it determines that



Transmission Service Agreement

the TSP has, directly or indirectly or through an agent, engaged in corrupt practice, fraudulent practice, coercive practice, undesirable practice or restrictive practice in the Bid process. In such an event, the Nodal Agency shall forfeit the Contract Performance Guarantee of the TSP, without prejudice to any other right or remedy that may be available to the Nodal Agency hereunder or subsistence otherwise.

19.20.2 Without prejudice to the rights of the Nodal Agency under Clause 19.20.1 hereinabove and the rights and remedies which the Nodal Agency may have under this Agreement, if a TSP is found by the Nodal Agency to have directly or indirectly or through an agent, engaged or indulged in any corrupt practice, fraudulent practice, coercive practice, undesirable practice or restrictive practice during the Bid process, or after the issue of Letter of Intent (hereinafter referred to as Lol) or after the execution of the agreement(s) required under Sharing Regulations, the Nodal Agency may terminate the Agreement without being liable in any manner whatsoever to the TSP. Further, the TSP & its Affiliates shall not be eligible to participate in any tender or RFP issued by any BPC for an indefinite period from the date such TSP is found by the Nodal Agency to have directly or indirectly or through an agent, engaged or indulged in any corrupt practice, fraudulent practice, coercive practice, undesirable practice or restrictive practices, as the case may be.

19.20.3 For the purposes of this Clause 19.20, the following terms shall have the meaning hereinafter respectively assigned to them:

(a) “**corrupt practice**” means (i) the offering, giving, receiving, or soliciting, directly or indirectly, of anything of value to influence the actions of any person connected with the Bid process (for avoidance of doubt, offering of employment to or employing or engaging in any manner whatsoever, directly or indirectly, any official of the BPC who is or has been associated or dealt in any manner, directly or indirectly with the Bid process or the Lol or has dealt with matters concerning the RFP Project Documents or arising there from, before or after the execution thereof, at any time prior to the expiry of one year from the date such official resigns or retires from or otherwise ceases to be in the service of the BPC, shall be deemed to constitute influencing the actions of a person connected with the Bid Process); or (ii) engaging in any manner whatsoever, whether during the Bid Process or after the issue of the Lol or after the execution of the RFP Project Documents, as the case may be, any person in respect of any matter relating to the Project or the Lol or the RFP Project Documents, who at any time has been or is a legal, financial or technical adviser of the BPC in relation to any matter concerning the Project;

(b) “**fraudulent practice**” means a misrepresentation or omission of facts or suppression of facts or disclosure of incomplete facts, in order to influence the Bid process;

(c) “**coercive practice**” means impairing or harming, or threatening to impair or harm, directly or indirectly, any person or property to influence any person’s participation or action in the Bid process;

(d) “**undesirable practice**” means (i) establishing contact with any person connected with or employed or engaged by the BPC with the objective of canvassing, lobbying or in any manner influencing or attempting to influence the Bid process; or (ii) having a Conflict of Interest; and

(e) “**restrictive practice**” means forming a cartel or arriving at any understanding or arrangement among Bidders with the objective of restricting or manipulating a full and fair competition in the Bid process;

19.21 Compliance with Law:

Despite anything contained in this Agreement but without prejudice to Article 12, if any provision of this Agreement shall be in deviation or inconsistent with or repugnant to the provisions contained in the Electricity Act, 2003, or any rules and regulations made there under, such provision shall be deemed to be amended to the extent required to bring it into compliance with the aforesaid relevant provisions as amended from time to time.



IN WITNESS WHEREOF, THE PARTIES HAVE CAUSED THIS AGREEMENT TO BE EXECUTED BY THEIR DULY AUTHORISED REPRESENTATIVES AS OF THE DATE AND PLACE SET FORTH ABOVE.

1. For and on behalf of TSP

[Handwritten Signature]

ADITYA KISLAY

[Signature, Name, Designation and Address]

2. For and on behalf of [Insert name of the Nodal Agency]

[Handwritten Signature]

JASBIR SINGH

Executive Director

[Signature, Name, Designation and Address]

CENTRAL TRANSMISSION UTILITY OF INDIA LTD.
(A Wholly Owned Subsidiary of
Power Grid Corporation of India Ltd)
(A Government of India Enterprise)
* No.-2, Sector-29, Gurgaon- 122 001 (Haryana)

WITNESSES:

1. For and on behalf of
: BPC

[Handwritten Signature]
(RITAM B B S) AM (Engg), RBCPDCL

[Signature]

.....
[Insert, Name, Designation and Address of the Witness]

2. For and on behalf of
: Nodal Agency

[Handwritten Signature]

[Signature]

Deepak Krishnan, manager, CTUIL

.....
[Insert Name, Designation and Address of the Witness]



SCHEDULES



Schedule: 1**Project Description and Scope of Project****Scope of the Project:**

Sl. No.	Scope of the Transmission Scheme	Scheduled COD in months from Effective Date
1	LILO of both circuits of Parli(M) – Karjat(M)/Lonikand-II (M) 400 kV D/c line (twin moose) at Kallam PS	18 months
2	4 Nos. 400 kV line bays at Kallam PS for LILO of both circuits of Parli(M) – Karjat(M)/Lonikand-II(M) 400 kV D/c line (twin moose) at Kallam PS <ul style="list-style-type: none"> 400 kV line bays (AIS) – 4 Nos. (for Kallam PS end) 	
3	63 MVAR, 420 kV switchable line reactor (with NGR bypassing arrangement) on each ckt at Kallam PS end of Karjat – Kallam 400 kV D/c line(~140km) <ul style="list-style-type: none"> 63 MVAR, 420 kV switchable line reactor including Switching equipment - 2 Nos. (at Kallam end) 	

Note:

- TSP of Kallam PS (Kallam Transmission Ltd.) shall provide requisite space at Kallam PS for the above scope of work.
- The 50 MVAR fixed line reactors on each ckt at Parli (M) end of Kallam – Parli (M) 400 kV D/c line shall be converted into switchable line reactors (with NGR bypass arrangement & provision of inter-tripping scheme to trip the line reactors along with the main line breakers) by MSETCL in matching time-frame of the above scheme. MSETCL vide email dated 08.06.2023 has informed that conversion of fixed 50 MVAR line reactor at 400 kV Parli (M) (Girwali) end into switchable reactor is feasible.

Project Description

Govt. of India has set a target for establishing 500 GW capacity from non-fossil energy sources by 2030. In this direction, 2GW capacity has been identified at Kallam PS. Transmission System for evacuation of power from RE Projects in Osmanabad area (1 GW) in Maharashtra is presently under implementation by Kallam Transmission Ltd. which is expected by Oct'23. Further, augmentation of transformation capacity at Kallam PS by 2x500 MVA, 400/220 kV ICTs (3rd & 4th) along with 220kV bays for RE interconnection is also under implementation for enabling interconnection of additional 1GW at 220kV level of Kallam PS (expected by May'24).

Additional connectivity has also been granted to M/ s Torrent at 400kV level (1 no. bay) and hence there is cumulative requirement of evacuation of about 3.25GW (2GW at 220kV level and 1.25GW at 400kV level) from Kallam PS.

The subject Transmission system shall enable evacuation of power beyond 2GW at Kallam PS (upto 3.25GW), by alleviating constraints in the area, using Renewable energy sources and is expected to play a significant role in fulfilling India's vision of 500 GW of non-fossil generation capacity by 2030.

The subject scheme includes LILO of both circuits of Parli(M) – Karjat(M)/Lonikand-II (M) 400 kV D/c line (twin moose) at Kallam PS along with 63 MVAR, 420 kV switchable line reactor (with NGR bypassing arrangement) on each ckt at Kallam PS end of Karjat – Kallam 400 kV D/c line. The scheme will facilitate integration of 1.25GW power beyond 2GW at Kallam PS (i.e. upto 3.25GW).

The subject Transmission system was deliberated and approved in the 14th NCT meeting held on 09.06.2023. National Committee on Transmission vide Gazette notification dated 19.07.2023 has appointed RECPDCL as BPC for implementation of the subject transmission scheme through TBCB route.

Central Transmission Utility of India Limited



84

Kallam Transco Limited



1 April 2024

SPECIFIC TECHNICAL REQUIREMENTS FOR TRANSMISSION LINE

The design, routing and construction of transmission lines shall be in accordance with Chapter V, Part A of CEA (Technical Standards for Construction of Electrical Plants and Electric Lines) Regulations 2022, as amended from time to time. Other CEA Regulations and MoP guidelines, as applicable, shall also be followed.

- A.1.0 Selection of tower type shall be made as per CEA Regulations, however in case lattice type towers are used, the following shall also be applicable:
- A.2.0 Steel section of grade E 250 and/or grade E 350 as per IS 2062, only are permitted for use in towers, extensions, gantry structures and stub setting templates. For towers in snowbound areas, steel sections shall conform to Grade-C of IS-2062.
- A.3.0 Towers shall be designed as per IS-802:2015, however the drag coefficient of the tower shall be as follows: -

Solidity Ratio	Drag Coefficient
Upto 0.05	3.6
0.1	3.4
0.2	2.9
0.3	2.5
0.4	2.2
0.5 and above	2.0

- A.4.0 Transmission Service Provider (TSP) shall adopt any additional loading/design criteria for ensuring reliability of the line, if so desired and /or deemed necessary.
- A.5.0 Transmission line shall be designed considering wind zones as specified in wind map given in National Building Code 2016, Vol.1. The developer shall also make his own assessment of local wind conditions and frequent occurrences of high intensity winds (HIW) due to thunderstorms, dust-storms, downburst etc. along the line route and wherever required, higher wind zone than that given in wind map shall be considered for tower design for ensuring reliability of line. Further, for transmission line sections passing within a distance of 50 km from the boundary of two wind zones, higher of the two wind zones shall be considered for design of towers located in such sections.



- A.6.0 Selection of reliability level for design of tower shall be as per CEA Regulation (Technical Standards for Construction of Electrical Plants and Electric Lines) Regulations 2022, as amended from time to time.
- A.7.0 A) For power line crossing of 400 kV or above voltage level, large angle & dead end towers (i.e. D/DD/QD) shall be used on either side of power line crossing.
- B) For power line crossing of 132 kV and 220 kV voltage level, angle towers (B/C/D/DB/DC/DD/QB/QC/QD) shall be used on either side of power line crossing depending upon the merit of the prevailing site condition and line deviation requirement.
- C) For power line crossing of 66 kV and below voltage level, suspension/tension towers shall be provided on either side of power line crossing depending upon the merit of the prevailing site condition and line deviation requirement.
- D) For crossing of railway tracks, national highways and state highways, the rules/ regulations of appropriate authorities shall be followed.
- A.8.0 The relevant conductor configuration for 400kV shall be as follows: -

Transmission line	ACSR Conductor specified	Equivalent AAAC conductor based on 53% conductivity of Al Alloy	Equivalent minimum size of AL59 conductor based on 59% conductivity of AL Alloy*	Sub-conductor Spacing
400kV D/C (Twin Moose) transmission lines	<p>Moose: Stranding 54/3.53mm-Al + 7/3.53 mm-Steel, 31.77 mm diameter 528.5 sq. mm, Aluminium area,</p> <p>Maximum DC Resistance at 20°C (Ω/km): 0.05552</p>	<p>Stranding details 61/3.55mm 31.95mm diameter; 604 sq. mm Aluminium alloy area</p> <p>Maximum DC Resistance at 20°C (Ω/km): 0.05506</p>	<p>Stranding details: 61/3.31mm 29.79 mm diameter; 525 sq. mm Aluminium alloy area</p> <p>Maximum DC Resistance at 20°C (Ω/km): 0.0566</p>	450 mm



	Minimum UTS: 161.20 kN	Minimum UTS: 159.80 kN	Minimum UTS: 124.70 kN	
--	---------------------------	---------------------------	---------------------------	--

Note:

- *To Select any size above the minimum, the sizes mentioned in the Indian standard IS-398(part-6) shall be followed.
- The transmission lines shall have to be designed for a maximum operating conductor temperature of 85 deg C.

A.9.0 The required phase to phase spacing and horizontal spacing for 400kV line shall be governed by the tower design as well as minimum live metal clearances for 400kV voltage level under different insulator swing angles. However, the phase to phase spacing for 400kV line shall not be less than 8 m.

A.10.0 Electrical clearances including minimum live metal clearance, ground clearance and minimum mid span separation between earth wire and conductor as given below shall be considered:

Minimum live metal clearances for 400 kV line:(i) Under stationary conditions

From tower body: 3.05 m

(ii) Under swing conditions

Wind pressure Condition	Minimum electrical clearance
a) Swing angle (22°)	3.05 m
b) Swing angle (44°)	1.86 m

(iii) Minimum ground clearance: 8.84 m

(iv) Minimum mid span separation between earth-wire and conductor: 9.0 m

A.11.0 Shielding angle shall not exceed 20 deg for 400kV D/C Line transmission line.

A.12.0 The Fault current for design of line shall be 63kA for 1 sec for 400kV.

A.13.0 In case of 400kV & above voltage class lines, at least one out of two earth wires shall be OPGW and second earth wire, if not OPGW, shall be either of galvanized standard steel (GSS) or Aluminium Alloy Conductor Steel Reinforced (AACSR) conductor type. or any other suitable conductor type depending upon span length and other technical consideration.



- A.14.0 Each tower shall be earthed such that tower footing impedance does not exceed 10 ohms. Pipe type or Counterpoise type earthing shall be provided in accordance with relevant IS. Additional earthing shall be provided on every 7 to 8 kms distance for direct earthing of both shield wires. If site condition demands, multiple earthing or use of earthing enhancement compound shall be used.
- A.15.0 Pile type foundation shall be used for towers located in river or creek bed or on bank of river having scourable strata or in areas where river flow or change in river course is anticipated, based on detailed soil investigation and previous years' maximum flood discharge of the river, maximum velocity of water, highest flood level, scour depth & anticipated change in course of river based on river morphology data of at least past 20 years to ensure availability and reliability of the transmission line.
- A.16.0 Transmission line route shall be finalized, in consultation with appropriate authorities so as to avoid the habitant zones of endangered species and other protected species. Bird diverters, wherever required, shall be provided on the line.
- A.17.0 Wherever, transmission lines are passing through cyclone prone areas i.e. areas upto 60 km from coast following shall also be applicable:
- Terrain category-I, with terrain roughness factor (K2) of 1.08 shall be considered for tower design for exposed open terrain with few or no obstruction which also includes open sea coasts, open stretch of water, desert and flat treeless plains
 - Importance factor for cyclonic region (K4) of 1.3 shall be considered for tower design.
 - The number of consecutive spans between the section points/ angle point shall not exceed 10 spans or 3km instead of conventional practice of 15 spans or 5km, in order to reduce the failure of such towers in coastal areas due to cascading effect. The section shall be terminated with tension tower/ angle tower and angle of deviation should be based on the site requirement.
- A.18.0 Wherever, transmission lines are passing through cyclone prone areas (i.e. areas upto 60 km from coast)/ creek regions/ aggressive soil areas following shall also be applicable:
- The fabricated tower parts and stubs shall have a minimum overall zinc coating of 900 g/m² of surface area except for plates and sections below 5 mm which shall have a minimum overall zinc coating of 610 g/m² of surface area. The average zinc coating for all sections and plates 5mm and above shall be maintained as 127 microns and that for plates and



sections below 5mm shall be maintained as 87 microns.

- b) Ready mix concrete of M30 Grade shall be used to avoid use of locally available saline water. However, design mix concrete of M30 Grade conforming to IS 456 with potable water can be used at locations where transportation of ready-mix concrete is not feasible. Minimum cement content in any case shall not be less than 330 kg/m³.
- c) The surface of the reinforced steel shall be treated with epoxy-based coating to enhance corrosion performance of foundation. Use of epoxy coated reinforcement in foundation shall be as per IS 13620. In addition, two (2) coats of bituminous painting of minimum 1.6 kg/m² per coat shall be applied on all exposed faces of foundation (i.e. pedestal & base slab).
- d) Double coat 20 mm thick cement plaster shall be provided on all exposed concrete surface as well up to 300 mm below ground level to give protection to concrete surface from environmental and saline effect.
- e) Before coping of chimney top portion, three coats of anti-corrosive paint of minimum 30-35 microns dry film thickness each shall be applied on the stub in the 50mm coping portion as well as up to 350 mm above CL portion.

A.19.0 The raised chimney foundation is to be provided in areas prone to flooding/water stagnation like paddy field /agricultural field & undulated areas to avoid direct contact of water with steel part of tower. The top of the chimney of foundation should be at least above HFL (High Flood Level) or the historical water stagnation/ logging level (based on locally available data) or above High Tide Level or 500 mm above Natural Ground level (whichever is higher).

A.20.0 Routing of transmission line through protected areas of India shall be avoided to the extent possible. In case, it is not possible to avoid protected areas, the towers of the transmission line upto 400 kV level which are installed in protected areas shall be designed for Multi-circuit (4 circuits) configuration of same voltage level considering reliability level of at least two (2). The top two circuits of these multi-circuit towers shall be used for stringing of the transmission line under present scope and the bottom two circuits shall be made available for stringing of any future transmission line of any transmission service providers/ State transmission utilities/Central transmission utilities passing through the same protected area. Further, the configuration and coordinates of such transmission towers shall be submitted to CEA, CTU & BPC by the TSP.



- A.21.0 The TSP shall abide by the Guidelines of CEA w.r.t. shifting of transmission lines for NHAI projects and other projects.
- A.22.0 Safety precautions in regards to gas/oil pipe lines in vicinity of Transmission lines shall be taken in coordination with gas/ petroleum authorities.



SPECIFIC TECHNICAL REQUIREMENTS FOR SUBSTATION

The proposed extension of Kallam substation shall be conventional Air Insulated Switchgear (AIS) type generally conforming to the requirements of CEA (Technical Standards for Construction of Electrical Plants and Electric Lines) Regulations 2022, as amended from time to time. Other CEA Regulations and MoP guidelines, as applicable, shall also be followed.

B.1.0 Salient features of Substation Equipment and Facilities

The design and specification of substation equipment are to be governed by the following factors:

B.1.1 Insulation Coordination

The system design parameters for substations/switchyards shall be as given below:

Sl. No	Description of parameters	400kV Kallam (AIS)
		S/s 400 kV System
1.	System operating voltage	400kV
2.	Maximum voltage of the system (rms)	420kV
3.	Rated frequency	50Hz
4.	No. of phase	3
5.	Rated Insulation levels	
i)	Lighting Impulse withstand voltage for (1.2/50 micro sec.) - for Equipment other than Transformer and Reactors - for Insulator String	1425kVp 1550kVp
ii)	Switching impulse withstand voltage (250/2500 micro sec.) dry and wet	1050kVp
iii)	One minute power frequency dry withstand voltage (rms)	630 kV
6.	Corona extinction voltage	320 kV
7.	Max. radio interference voltage for frequency between 0.5 MHz and 2MHz	1000 micro- volts at 266kV rms
8.	Minimum creepage distance for insulator string/ longrod insulators/outdoor bushings	13020 mm (31mm/kV)
9.	Minimum creepage distance for switchyard equipment	10500mm (25mm/kV)
10.	Max. fault current	63kA
11.	Duration of fault	1 sec



B.1.2 Switching Scheme

The switching schemes, as mentioned below, shall be adopted at various voltage levels of substation/switchyard:

Substation	400kV side
400kV Kallam Extn. (AIS)	One & half breaker

Notes: -

- i) For one and half breaker switching scheme, any double circuit line consisting of two numbers of feeders and originating from the same transmission or generating switchyard shall not be terminated in one diameter.
- ii) A diameter in one and half breaker scheme is a set of 3 circuit breakers with associated isolators, earth switches, current transformers etc. for controlling of 2 numbers of feeders.
- iii) Connection arrangement of Switchable Line reactors shall be such that it can be used as Line reactor as well as Bus reactor with suitable NGR bypass arrangement.
- iv) TSP shall plan distribution of line and transformer feeders to bus bar in such a way that all power can be evacuated successfully without crossing thermal limit at any point of bus-bar.
- v) 400kV line bays shall be constructed such that provision is kept for future switchable line reactors.
- vi) Kallam S/S:
400kV: Bays identified for LILLO of both circuits of Parli(M) – Karjat(M)/Lonikand-II (M) 400 kV D/c line are shown in attached SLD & GA drawing of Kallam S/S. As per the GA drawing out of 4 circuits, 3 circuits shall be terminated in existing diameters for which main bays are to be constructed under the present scope. These 3 circuits shall be terminated in main bay nos. 413,416 & 419 respectively. Remaining 1 circuit shall be terminated in new diameter for which main & tie bays are to be constructed under present scope.

Further, Line gantries shall be constructed for termination of all the four (4) circuits considering the provision of switchable line reactor as shown in GA drawing.

B.2.0 Substation Equipment and facilities (Voltage level as applicable):

The switchgear shall be designed and specified to withstand operating conditions and duty requirements. All equipment shall be designed considering the following capacity.



Sl. No	Description of bay	400kV Kallam (AIS) Extn.
		400kV
1.	Bus Bar	As per existing
2.	Line bay	3150A

B.2.1 Shunt Reactors

B.2.1.1 420kV, 3-Phase, Shunt Reactor

63MVAR, 420 KV, 3-Phase Reactor shall conform to CEA's "Standard Specifications and Technical Parameters for Transformers and Reactors (66 kV and above)" as amended up to date available on CEA website.

The Ohmic value of NGR for Line Reactors shall be as follows:

Sl. No.	Line Name	NGR value
1.	63 MVAR, 420 kV switchable line reactor on each ckt of Karjat – Kallam 400kV D/c line at Kallam PS end.	400 Ohms

B.2.2 400kV AIS Substation equipment (as applicable)

B.2.2.1 Circuit Breakers (AIS)

The circuit breakers and accessories shall conform to IEC: 62271-100, IEC: 62271-1 and shall be of SF6 Type. The circuit breakers shall be of class C2-M2 (as per IEC) with regard to restrike probability during capacitive current breaking and mechanical endurance. Each breaker would have two sets of trip circuits which would be connected to separate DC supplies for greater reliability. The rated break time shall not exceed 40ms for 400kV circuit breakers. The Circuit breakers controlling 400kV lines of more than 200km length shall be provided either with pre-insertion closing resistor of 400 ohms with 8ms insertion time or with Controlled Switching Device. 400kV Circuit breakers shall be provided with single phase and three phase auto reclosing. The short line fault capacity shall be same as the rated capacity and this is proposed to be achieved without use of opening resistors. Controlled switching device shall be provided in 400kV Circuit breakers of switchable line reactor bay and in Main & Tie bay circuit breakers of line with non-switchable line reactors and Bus reactors.

B.2.2.2 Isolators (AIS)

The isolators shall comply to IEC 62271-102 in general. 400kV isolator design shall be double break type. All isolators and earth switches shall be motor



operated. Earth switches shall be provided at various locations to facilitate maintenance. Isolator rated for 400kV shall be of extended mechanical endurance class - M2 and suitable for bus transfer current switching duty as per IEC-62271-102. Main blades and earth blades shall be interlocked and interlock shall be fail safe type. 400kV earth switches for line isolator shall be suitable for induced current switching duty as defined for Class-B.

B.2.2.3 Current Transformers (AIS)

Current Transformers shall comply with IEC 61869 in general. All ratios shall be obtained by secondary taps only. Generally, Current Transformers (CT) for 400kV shall have six cores (four for protection and two for metering). The burden and knee point voltage shall be in accordance with the requirements of the system including possible feeds for telemetry. Accuracy class for protection core shall be PX and for metering core it shall be 0.2S. The rated burden of cores shall be closer to the maximum burden requirement of metering & protection system (not more than 20VA for metering core) for better sensitivity and accuracy. The instrument security factor shall be less than 5 for CTs upto 400kV voltage class.

B.2.4.1 Capacitive Voltage Transformers (AIS)

Capacitive Voltage transformers shall comply with IEC 61869 in general. These shall have three secondaries out of which two shall be used for protection and one for metering. Accuracy class for protection cores shall be 3P and for metering core it shall be 0.2. The Capacitive voltage transformers on lines shall be suitable for Carrier Coupling. The Capacitance of CVT for 400kV shall be of 4400/8800 pF depending on PLCC requirements. The rated burden of cores shall be closer to the maximum burden requirement of metering & protection system (not more than 50VA for metering core) for better sensitivity and accuracy.

B.2.4.2 Surge Arresters (AIS)

336 kV Station High (SH) duty gapless type Surge arresters with thermal energy (W_{th}) of minimum 12 kJ/kV conforming to IEC 60099-4 in general shall be provided for 400kV system. Other characteristics of Surge arrester shall be chosen in accordance with system requirements. Surge arresters shall be provided near line entrances, Transformers & Reactor so as to achieve proper insulation coordination. Surge Arresters shall be provided with porcelain/ polymer housing fitted with pressure relief devices. A leakage current monitor with surge counter shall be provided with each surge arrester.

B.2.5 Protection Relaying & Control System

The protective relaying system proposed to be provided for transmission lines, auto-transformers, reactors and bus bars to minimize the damage to the equipment in the events of faults and abnormal conditions, is dealt in this section.



All main protective relays shall be numerical type with IEC 61850 communication interface and should have interoperability during integration of numerical relays to communicate over IEC61850 protocol with RTU/SAS/IEDs of different OEMs. All numerical relays shall have built in disturbance recording feature.

The protection circuits and relays of transformer and reactor shall be electrically and physically segregated into two groups each being independent and capable of providing uninterrupted protection even in the event of one of the protection groups failing, to obtain redundancy, and to take protection systems out for maintenance while the equipment remains in service.

a) Transmission Lines Protection

400kV lines shall have Main-I numerical three zone distance protection scheme with carrier aided inter-tripping feature. 400kV lines shall also have Main-II numerical distance protection scheme like Main-I but from different make that of Main-I. The Main-I and Main-II protection relays of same make may be provided only if they are of different hardware & manufacturing platform or different principle of operation.

However, Line Current Differential relay (with back up distance protection feature) as Main-I and Main-II shall be considered at both ends for short lines (line length below 30km) having Fibre Optic communication link. Differential relay at remote end shall be provided by the TSP. Associated power & control cabling and integration with SAS at remote end shall be provided by respective bay owner.

In case of loop in loop out of transmission lines, the existing protection scheme shall be studied and suitable up-gradation (if required) shall be carried out.

Further, all 400kV lines shall be provided with single and three phase auto-reclosing facility to allow reclosing of circuit breakers in case of transient faults. These lines shall also be provided with distance to fault locators to identify the location of fault on transmission lines.

All 400kV lines shall also be provided with two stages over voltage protection. Over voltage protection & distance to fault locator may be provided as in-built feature of Main-I & Main-II protection relays. Auto reclose as built-in function of Bay Control Unit (BCU) is also acceptable.

The Main-I and Main-II protection relays shall be fed from separate DC sources and shall be mounted in separate panels.

For 400kV transmission lines, directional IDMT earth fault relay should be provided as standalone unit or in-built feature of Main-I and Main -II feature.

Central Transmission Utility of India Limited



95

Kallam Transco Limited

April 2024



b) 400kV Reactor Protection

Reactor shall be provided with the following protections:

- i) Numerical Differential protection.
- ii) Numerical Restricted earth fault protection
- iii) Numerical Back-up impedance protection

Besides these, reactors shall also be provided with Buchholz relay, MOG with low oil level alarm, protection against oil and winding temperatures & pressure relief device, etc.

c) Bus bar Protection

The high speed low impedance type bus bar differential protection, which is essential to minimize the damage and maintain system stability at the time of bus bar faults, shall be provided for 400kV buses. Duplicated bus bar protection is envisaged for 400kV bus-bar protection. Bus bar protection scheme shall be such that it operates selectively for each bus and incorporate necessary features required for ensuring security. The scheme shall have complete bus bar protection for present as well as envisaged future bays i.e., input / output modules for future envisaged bays shall also be provided.

In case, the bus section is provided, then each side of bus section shall have separate set of bus bar protection schemes.

For existing substations, the existing bus bar protection shall be augmented as per requirement.

d) Local Breaker Back up Protection

This shall be provided for each 400kV circuit breakers and will be connected to de-energize the affected stuck breaker from both sides.

Notes:

1. LBB & REF relays shall be provided separately from transformer differential relay.
2. LBB relay may also be provided as built-in protection function of distributed bus bar protection scheme; however in such case separate LBB relay shall be provided for tie bays (in case of One and Half breaker scheme).
3. Over fluxing & overload protection can be provided as built-in feature of differential relay.
4. In 400kV switchyard, if spare bay of half diameter is identified as future, Tie CB relay panel shall be with Auto-reclosure feature.



B.2.6 Substation Automation System

- a) For all the new substations, state of art Substation Automation System (SAS) conforming to IEC-61850 shall be provided. The distributed architecture shall be used for Substation Automation system, where the controls shall be provided through Bay control units. The Bay control unit is to be provided bay wise for voltage level 400kV and above. All bay control units as well as protection units are normally connected through an Optical fibre high speed network. The control and monitoring of circuit breaker, dis-connector, re-setting of relays etc. can be done from Human Machine Interface (HMI) from the Control Room.

The functions of control, annunciation, disturbance recording, event logging and measurement of electrical parameters shall be integrated in Substation Automation System.

At new substations, the Substation Automation System (SAS) shall be suitable for operation and monitoring of the complete substation including proposed future bays/elements.

In existing substations with Substation automation system (SAS), augmentation of existing SAS shall be done for bays under present scope.

In existing Substations where Substation automation is not provided, control functions shall be done through control panels.

Necessary gateway & modems (as required) shall be provided to send data to RLDC/SLDC as per their requirement. Any augmentation work at RLDC/SLDC is excluded from TSP's scope. However, all the configuration work at substation end required to send data to RLDC/SLDC shall be in the scope of TSP.

b) Time synchronization equipment

Time synchronization equipment complete in all respect including antenna, cable, processing equipment required to receive time signal through GPS or from National Physical Laboratory (NPL) through INSAT shall be provided at new substations. This equipment shall be used to synchronize SAS & IEDs etc.

B.3.0 Substation Support facilities

Certain facilities required for operation & maintenance of substations as described below shall be provided at new substation. In existing substation, these facilities have already been provided and would be extended/ augmented as per requirement.



B.3.1 AC & DC power supplies

For catering the requirements of three phase & single phase AC supply and DC supply for various substation equipment (for present and future scope), existing facilities shall be augmented as required.

B.3.2 Fire Fighting System

Fire-fighting system for substation including transformer & reactor shall conform to CEA (Measures Relating to Safety & Electric Supply) Regulations, 2023, as amended time to time.

Further, adequate water hydrants and portable fire extinguishers shall be provided in the substations. The main header of firefighting system shall be suitable for extension to bays covered under the future scope; necessary piping interface in this regard shall be provided.

At existing substations, the fire-fighting systems as available shall be extended to meet the additional requirements.

B.3.3 Oil evacuating, filtering, testing & filling apparatus

To monitor the quality of oil for satisfactory performance of transformers, shunt reactors and for periodical maintenance necessary oil evacuating, filtering, testing and filling apparatus would be provided at new substations. Oil storage tanks of adequate capacities for storage of transformer oil would be provided.

B.3.4 Illumination

Normal & emergency AC & DC illumination shall be provided adequately in the control room & other buildings of the substation. The switchyard shall also be provided with adequate illumination.

Lighting of the entire control room building, fire-fighting pump house, other building (if any) and switchyard shall be done by LED based low power consumption luminaries.

B.3.5 Control Room

For new substation, substation control room shall be provided to house substation work stations for station level control (SAS) alongwith its peripheral and recording equipment, AC & DC distribution boards, DC batteries & associated battery chargers, Fire Protection panels, Telecommunication panels & other panels as per requirements. Air conditioning shall be provided in the building as functional requirements. Main cable trenches from the control room shall have adequate space provision for laying of cables from control room for all the future bays also.

At existing substations, the adequacy of size of control room shall be ascertained and the same shall be augmented as per requirement.



B.3.7 Control Concept

All the EHV circuit breakers in substation/switching stations shall be controlled and synchronized from the switchyard control room/remote control center. All the isolators shall have control from remote/local whereas the earth switches shall have local control only.

B.3.8 Visual monitoring system (VMS) for watch and ward of substation premises:

Visual monitoring system for effective watch and ward of substation premises shall cover all the transformers and reactors, all other major AIS Equipment (such as CB, isolators, CT, CVT, SA etc. as applicable), GIS bays, panel room, all the gates of switchyard and all entry and exit points of control room building and accordingly the location of cameras shall be decided. The camera shall be high definition color CCD camera with night vision feature. The VMS data partly/completely shall be recorded (minimum for 15 days) at least @25fps (or better) and stored on network video recorder. The system shall use video signals from various cameras installed at different locations, process them for viewing on workstations/monitors in the control room and simultaneously record all the cameras.

Mouse/keyboard controllers shall be used for pan, tilt, zoom and other functions of the desired camera. The Visual Monitoring System shall have provision of WAN connectivity for remote monitoring.

All camera recordings shall have Camera ID & location/area of recording as well as date/time stamp. The equipment should generally conform to Electromagnetic compatibility requirement for outdoor equipment in EHV substation.

At existing substations, the visual monitoring system if available shall be augmented as per existing or better specification as required.

B.4 General Facilities

- a) Line Gantry/Towers are envisaged for bays under present scope only. However, for adjacent future line bay, tower shall be designed for extension (considering Quad conductors for 400kV future lines) wherever applicable.
- b) Bay extension works at existing substation shall be executed by TSP in accordance with the requirement/provisions mentioned above. However, interface points shall be considered keeping in view the existing design/arrangement at the substation.
- c) TSP has to arrange for construction power and water on its own.
- d) All outdoor steel structures including anchor/foundation bolts shall be fully galvanized. The weight of the zinc coating shall be at least 610 g/m². However, for coastal/creek regions it shall be at least 900 g/m².



- e) In 400kV switchyard, if spare bay of half diameter is identified as future, all the equipment for Tie & Future Bay shall be designed considering the current rating of line bay i.e., 3150A.
- f) All electrical equipment shall be installed above Highest Flood Level and where such equipment is not possible to be installed above Highest Flood Level, it shall be ensured that there is no seepage or leakage or logging of water.

B.5 EXTENSION OF EXISTING SUBSTATION

The following drawings/details of existing substation is attached with the RFP documents for further engineering by the bidder.

Sl. No.	Drawing Title	Drawing No./Details	Rev. No.
A.	400kV Kallam S/S		
1.0	Single Line Diagram	IGT-KTL-ELEC-SLD001	-
2.0	General Arrangement	IGT-KTL-ELEC-LAY001	-
3.0	Earthmat Layout	Drawings for previous scheme are yet to be finalized by the developer	
4.0	Visual Monitoring System		
5.0	Bus Bar Protection		
6.0	Substation Automation System (SAS)	GE Make	-

Bidder is also advised to visit the substation sites and acquaint themselves with the topography, infrastructure such as requirement of roads, cable trench, drainage etc. and also the design philosophy.



SPECIFIC TECHNICAL REQUIREMENTS FOR COMMUNICATION

The communication requirement shall be in accordance with CEA (Technical Standards for Communication System in Power System Operations) Regulations, 2020, CEA (Technical Standards for Construction of Electrical Plants and Electric Lines) Regulations, 2022, CERC (Communication System for inter-State transmission of electricity) Regulations, 2017, and CEA (Cyber Security in Power Sector) Guidelines, 2021, all above documents as amended from time to time.

The complete ISTS communication system commissioned by TSP under the RFP shall be the asset of ISTS and shall be available for usage of ISTS requirements as suggested by CTU from time to time.

The protections for transmission line and the line compensating equipment shall have hundred percent back up communication channels i.e. two channels for tele- protection in addition to one channel for speech plus data for each direction.

In order to meet the requirement for grid management and operation of substations, Transmission Service Provider (TSP) shall provide the following:

C.1.0 LILO of both circuits of Parli(M) – Karjat(M)/Lonikand-II (M) 400 kV D/c line (twin moose) at Kallam PS.

On LILO of both circuits of 400 kV D/c Parli (M) – Karjat(M)/ Lonikhand-II (M) 400 kV D/c line (twin moose) at Kallam S/s, TSP shall supply, install & commission OPGW and earthwire as per Tower Configurations:

- (i) For Multi Circuit Tower Configuration: Two (2) no. OPGW cable containing 24 Fibres (24F) to be installed & commissioned by the TSP on both the Earthwire peaks
- (ii) For Double Circuit Tower configuration (for both Loop In and Loop Out portion): One (1) no. OPGW cable containing 24 Fibres (24 F) on one earthwire peak & conventional earthwire on other E/W peak for both Loop In and Loop Out Lines.

The TSP shall install OPGW cables from gantry of Kallam S/s up to the LILO tower with all associated hardware including Vibration Dampers, mid-way & gantry Joint Boxes (called OPGW Hardware hereafter) and finally terminate in Joint Boxes at Kallam S/s. The transmission line length is **15 kms (approx.)**. After LILO, if fiber length for links Parli (M) to Kallam PS and Kallam PS to Lonikhand (M) is above 225 kms then repeater shall be envisaged, otherwise line can be managed as a repeater less link.

TSP shall finalize the location of repeater station depending upon the actual site conditions. Further TSP shall comply to the requirements mentioned as per **Appendix-F.1**



Maintenance of OPGW Cable, OPGW Hardware & repeater equipment & items associated with repeater shelter shall be responsibility of TSP.

C.2.0 4 Nos. 400 kV line bays at Kallam PS for LILO of both circuits of Parli(M) – Karjat(M)/ Lonikand-II(M) 400 kV D/c line (twin moose) at Kallam PS

- (i) TSP shall supply, install & commission 1 no. FODP (72F or higher) alongwith panel and required Approach Cable (24F) with all associated hardware fittings from gantry tower to Bay Kiosk and from the Bay Kiosk to Control room.
- (ii) TSP shall supply, install & commission One STM-16 (FOTE) equipment alongwith panel/s supporting minimum three (3) directions with MSP (Multiplex Section Protection – 1+1) with necessary interfaces to meet the voice and data communication requirement among **Kallam S/s, Parli (M) S/s and Karjat(M)/ Lonikand-II (M) S/s**. The suitable DC Power Supply and backup to be provided for communication equipment.
- (iii) FOTE/FODP panel shall be installed in the new Bay Kiosk. The FOTE under present scope shall be integrated by TSP with the existing FOTE at control room of **Kallam S/s** which shall be communicating with respective control center. TSP to provide necessary FODP sub rack / Splice trays/ Patch cords etc. and optical interfaces/equipment in the existing FOTE/FODP panels in control room for integration with the existing FOTE for onwards data transmission.

In case spare optical direction is not available in the existing FOTE at the control room, the TSP shall coordinate with station owner to reconfigure the directions in existing FOTE at control room. Alternatively, The TSP may integrate the FOTE under the present scope with existing FOTE in the nearby Kiosk connected to the control room FOTE (if available with spare direction). For this purpose, TSP shall provide necessary FODP sub rack / Splice trays/ Patch cords etc. and suitable optical interfaces/ equipment in the existing FOTE/FODP panels in another Kiosk (SPR).

- (iv) FOTE & FODP can be accommodated in same panel to optimize space.
- (v) The new communication equipment under the present scope shall be compatible for integration with existing regional level centralized NMS. The local configuration of the new communication equipment shall be the responsibility of TSP. The configuration work in the existing centralized NMS for integration of new Communication equipment shall be done by Regional ULDC Team, however all the necessary support in this regard shall be ensured by TSP.



- (vi) The maintenance of all the communication equipment and software thereof including FOTE, PMU, FODP, approach cable, DCPS alongwith Battery Bank shall be the responsibility of TSP.

C.3.0 Specific Requirement for Phasor Measurement Units (PMUs)

TSP shall supply, install & commission required no. of Phasor Measurement Units (PMUs) PMUs at all the locations under the scope of TSP under this RFP as per CEA (Technical Standards for Construction of Electrical Plants and Electric Lines) Regulations, 2022 (alongwith all amendments if any), and all the applicable Regulations, Standards, Guidelines issued time to time. These PMUs shall be provided with GPS clock and LAN switch and shall connect with LAN switch of control room of respective substations/ generating stations with Fibre Optic cable. These PMUs shall be connected with the FOTE at Substation/ generating stations for onwards data transmission to the PDC (Phasor Data Concentrator) located at respective RLDC. Configuration work in existing PDC at RLDC for new PMU integration shall be done by respective RLDC, however all the necessary support in this regard shall be ensured by TSP. The maintenance of all the PMUs and associated equipment shall be the responsibility of TSP.

Note: Existing Station owner/s to provide necessary support to integrate different equipment & applications of new extended bays with the existing substation e.g. Communication (through FOTE), Voice etc. for smooth operation and monitoring of new added grid elements.



Appendix-F.1

Repeater Requirements

- If the repeater location is finalized in the Control Room of a nearby substation, TSP shall provide 1 no. OPGW (48F) on a single Earthwire peak with OPGW Hardware & mid-way Joint Boxes etc. of the line crossing the main line and 1 no. Approach Cable (48F) with all associated hardware fittings, to establish connectivity between crossing point of main transmission line up to the repeater equipment in substation control room.
TSP shall co-ordinate for Space & DC power supply sharing for repeater equipment.
TSP shall provide FODP, FOTE (with STM-16 capacity) with suitable interfaces require for link budget of respective link.

OR

- If the repeater location is finalized in the nearby substation premises, the TSP shall identify the Space for repeater shelter in consultation with station owner. Further TSP shall provide 1 no. OPGW (48F) on a single Earthwire peak with OPGW Hardware & mid-way Joint Boxes etc. of the line crossing the main line and 1 no. Approach Cable (48F) / UGFO (48F) with all associated hardware fittings, to establish connectivity between crossing point of main transmission line up to the substation where the repeater shelter is to be housed.
TSP shall provide repeater shelter along with FODP, FOTE (with STM-16 capacity) with suitable interfaces require for link budget of respective link, reliable power supply provisioning for AC and DC supply, battery bank, Air Conditioner and other associated systems.

OR

- If the repeater location is finalized on land near the transmission tower. TSP shall make the provisions for Land at nearby tower for repeater shelter. Further TSP shall provide 1 no. Approach Cable (48F) / UGFO (48F) with all associated hardware fittings to establish connectivity up to the location of repeater shelter.
TSP shall provide repeater shelter along with FODP, FOTE (with STM-16 capacity) with suitable interfaces require for link budget of respective link, reliable power supply provisioning for AC and DC supply, battery bank, Air Conditioner and other associated systems

Maintenance of OPGW Cable and **OPGW Hardware**, repeater equipment & items associated with repeater shelter shall be responsibility of TSP.



Proposed Communication for Transmission Scheme for Western Region Network Expansion scheme In Kallam area of Maharashtra

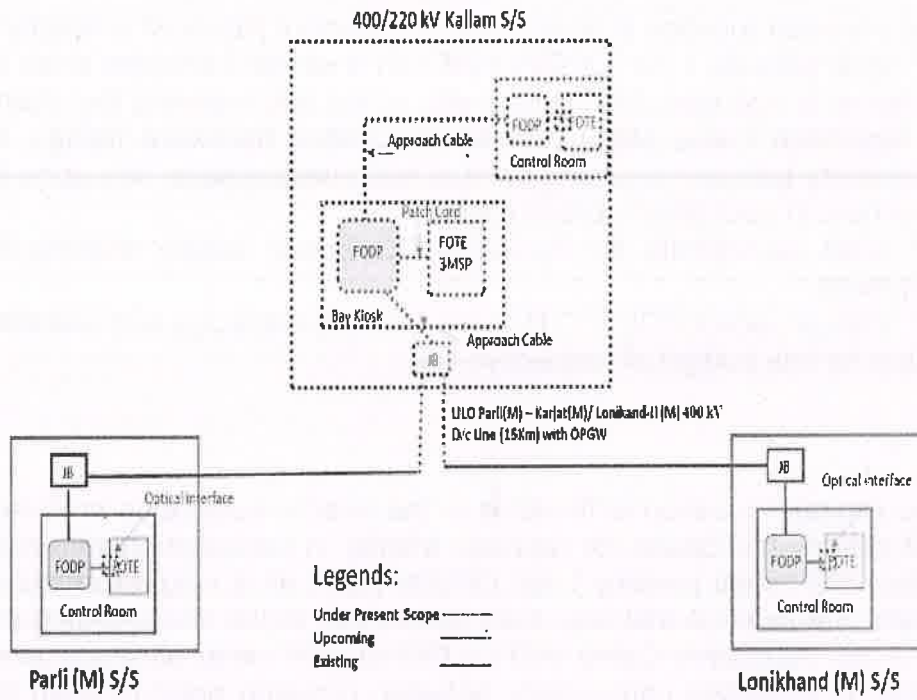

C.4.0 PLCC & PABX

Power line carrier communication (PLCC) equipment complete for speech, tele-protection commands and data channels shall be provided on each transmission line. The PLCC equipment shall in brief include the following: -

- Coupling device, line traps, carrier terminals, protection couplers, HF cables, PABX (if applicable) and maintenance and testing instruments.
- Coupling devices shall be suitable for phase-to-phase coupling for 400kV Transmission lines. The pass band of coupling devices shall have sufficient margin for adding communication channel in future if required. Necessary protection devices for safety of personnel and low voltage part against power frequency voltages and transient over voltage shall also be provided.
- The line traps shall be broad band tuned suitable for blocking the complete range of carrier frequencies. Line Trap shall have necessary protective devices such as lightning arresters for the protection of tuning device. Decoupling network consisting of line traps and coupling capacitors may also be required at certain substation in case of extreme frequency congestion.
- The carrier terminals shall be of single side-band (SSB) amplitude modulation (AM) type and shall have 4 kHz band width. PLCC Carrier terminals and Protection couplers shall be considered for both ends of the line.
- TSP shall provide/ undertake necessary addition/ modification/ shifting/ re-commissioning etc. of PLCC equipment due to LILO of transmission lines (wherever applicable).
 - LILO of both circuits of Parli(M) –Karjat(M)/Lonikand-II(M) 400kV D/c line at Kallam PS:

Sl. No	Line name	PLCC configuration
1	Parli(M) – Kallam 400kV D/c line.	1 set Analog PLCC + 1 set Digital Protection Coupler for each circuit at each end.
2	Karjat(M)- Kallam & Lonikand-II(M)-Kallam line	1 set Analog PLCC + 1 set Digital Protection Coupler for each circuit at each end.
Existing PLCC panels of Parli(M) –Karjat(M)/Lonikand-II(M) 400kV D/c line may also be utilized.		

- All other associated equipment like CVT, Line Trap, cabling, coupling device and HF cable shall also be provided by the TSP.



- Frequently Asked Queries:1.0 Transmission Line:

1.1 Please clarify that whether shutdowns for crossing of existing transmission lines of POWERGRID/STUs/ Power Evacuation Lines from Generation Plants/ Any other Transmission Licensee will be given to TSP on chargeable basis or free of cost.

Reply: Shutdowns for crossing of existing transmission lines of POWERGRID/ STUs/ Power Evacuation Lines from Generation Plants/ Any other Transmission Licensee will be given to TSP by the concerned owner of the lines as per their own terms & conditions. As far as shutdown of ISTS lines are concerned the same can be availed by approaching respective Regional Power Committee.

1.2 We understand that the suggested swing angle criteria are applicable for Suspension Insulator in Suspension Tower. Further, you are requested to provide similar swing angle and clearance criteria for Pilot Insulator with Jumper & Jumper.

Reply: It is clarified that the swing angle criteria (as mentioned in RFP) for transmission lines is applicable for Suspension Insulator in Suspension Tower. Further, as per Clause 3.0 of Specific Technical Requirements for transmission lines, Transmission service Provider (TSP) shall adopt any additional loading/design criteria for ensuring reliability of the line, if so desired and /or deemed necessary.

1.3 We request you to kindly allow that use of diamond configuration at Power line crossings and the existing owner of the lines may be directed to allow the same for the successful bidders.

Reply: Power line crossing including Diamond configuration is responsibility of the TSP. TSP shall formally submit the profile of the crossing section to the owner of the existing line suggesting proposed crossing alternatives. The crossing will have to be carried out as per approval of owner of the existing line.

1.4 It is requested you to kindly provide present status of Forest Clearances if any transmission line corridor area falling in wildlife forest / reserve forest/ mangroves.

Reply: Based on the preliminary route survey, the process of initiation of forest clearance for the forest stretches, if any, enroute the proposed line alignment will be initiated by way of writing letters to the concerned authority (ies). However, it may be noted that it will be the responsibility of TSP for obtaining forest clearance for the forest stretches as provided in the survey report and also for any forest area encountered during detailed survey.

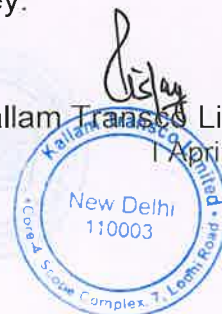

2.0 Substation

2.1 We understand that space for storage of O&M spare shall be provided by existing owner within the station boundary without any cost. Kindly confirm.

Reply: Space for storage of O&M spares shall be arranged by TSP on its own.

2.2 We presume that the O&M for the end Termination bays will be in the scope of the TSP and TSP shall not be liable for any payment towards O&M to the existing owner of the substation. Kindly confirm.

Reply: Operation and maintenance of the bays is solely responsibility of the TSP. TSP shall follow CEA's "Operation and Maintenance (O&M) guidelines and Standard Format for Memorandum of Understanding between New TSP and Existing TSP" issued by CEA vide its letter No. I/28514/2023 dated 22.06.2023 Copy of the guideline is available on CEA website at following link:

https://cea.nic.in/wp-content/uploads/pse_td/2023/06/om_guidelines.pdf

2.3 With reference to subject scheme of existing sub-station, we assumed following scope of work:

- (a) We assumed internal road is available and need not to consider in the present scope of work.
- (b) Drainage is available and need not to consider in the present scope of work.
- (c) Cable trench extension in adjacent to Main cable trench only under present scope of work.
- (d) Levelled area being provided by developer for bay extension.

Reply: Regarding requirement of internal road, drainage, cable trench, leveling of the bay extension area, bidder is advised to visit site and acquaint themselves with the provisions/facilities available at substation.

2.4 Kindly provide the soil investigation report of soil parameters of existing substation.

Reply: Bidder is advised to visit the substation site and ascertain the requisite parameters.

2.5 Kindly confirm, energy accounting of aux. power consumption. Whether it will be on chargeable basis or part of transmission loss.

Reply: It will be on chargeable basis.

2.6 We understand that VMS requirement is for unmanned stations only. For Manned stations VMS is not compulsory.

Central Transmission Utility of India Limited 108

Kallam Transco Limited

1 April 2024



Reply: VMS shall be provided in line with requirements of RfP document.

2.7 It is understood that Construction water and power shall be provided free of cost to TSP by respective substation owner for construction of new bays.

Reply: Arrangement of construction power & water is in the scope of TSP.

2.8 It is understood that existing fire hydrant system shall be extended by the TSP for bay extension.

Reply: Existing fire hydrant system shall be extended from existing system (if required)

2.9 Please clarify that Status of land acquisition for Substations. Whether the lands have been acquired by BPC and will be transferred to TSP.

Reply: The acquisition of land for substation is in the scope of TSP.

2.10 We understood that no any dedicated metering CT & CVT required for Line/feeders. Further, we understood that requisite Energy meters for various 765kV, 400kV & 220kV Feeders shall be provided & installed by CTU free of cost to TSP.

Reply: Dedicated metering CT and CVT are not required for line/feeders. Metering core of existing CT/CVT can be used provided accuracy class is matching with metering requirement. Requisite Special Energy Meters shall be provided and installed by CTU at the cost of TSP in C&P panel subject to space availability, else, in separate metering panel (to be provided by TSP at its cost).

2.11 It is understood that TSP to follow the RFP for Technical Requirement. Only interface drawings like CRP & SCADA shall be coordinated with existing S/S owner.

Reply: All necessary coordination shall be done with exiting s/s owner w.r.t interface along with augmentation required as per RfP.

2.12 We understand that there are only two communication channels, Chanel-1 for protection-1+ Speech via. PLCC, Chanel-2 for Protection-2 + data via. FOTE. Hence, we do not envisage any separate channel for speech + data as the same can be achieved with FOTE system. Therefore, we understand that TSP is allowed to implement best possible solutions accordingly. Kindly confirm.

Reply: PLCC equipment for all the transmission lines covered under the scheme (consisting of one set of analog PLCC channel along with circuit protection coupler and one set of Digital protection coupler for both ends) shall be provided by TSP. Further, OPGW based terminal equipment shall be utilized for Speech+ Data.

2.13 We understand that one set of analog circuit protection coupler shall be for PLCC and another set for Digital protection coupler for FOTE. Kindly confirm.



Reply: PLCC equipment for all the transmission lines covered under the scheme (consisting of one set of analog PLCC channel along with circuit protection coupler and one set of Digital protection coupler for both ends) shall be provided by TSP. Further, OPGW based terminal equipment shall be utilized for Speech+ Data.

3.0 Communication

3.1 What are the usage of OPGW, FOTE, PMU etc. under communication requirement of RFP?

Reply: User shall be responsible for providing compatible equipment along with appropriate interface for uninterrupted communication with the concerned control center and shall be responsible for successful integration with the communication system provided by CTU.

Communication systems e.g. OPGW, FOTE, PMU etc. are required for grid operation through RLDC/SLDC, speech communication, tele-protection and tele-metering.

3.2 Is space for installation of communication panels are provided to TSP in existing Substations incase new bays are in the scope of TSP?

Reply: The space replated issues are deliberated in the RFP itself. TSP to carry out survey of the existing substation for physical space requirement. In case space is not available in the existing substation then TSP shall accommodate the same in the respective bay SPR (Switchyard Panel Room)/Bay Kiosk/ Relay panel room in case of GIS s/s. Further, TSP to connect and integrate the proposed FOTE with the existing FOTE in the Relay Panel Room.

In Case 132kV Substation TSP shall accommodate the said panels either by extension of existing Relay Panel Room or other arrangements.

3.3 How is the OPGW laying done in case of LILO lines?

Reply: In case LILO lines are on same towers (e.g. both Line in and Line Out portion are on same towers, generally done LILO of S/C lines). Then 2x24F OPGW shall be required to install by TSP on both earthwire peak on 400kV & 765kV lines where two E/W peaks are available. On 220 & 133kV lines where only one E/W peak is available TSP to install one no. 48F OPGW.

Incase LILO lines are on different towers (e.g. both Line In and Line Out portion are on different towers, generally done LILO of D/C lines). Then 1x24F OPGW shall be required to install by TSP on one earthwire peak, on both Line In and Line Out portions of 400kV & 765kV lines. On 220 & 133kV lines where only one E/W peak is available TSP to install one no. 24F OPGW in place of conventional earthwire.



3.4 How is the OPGW laying done in case Multi circuit Towers?

Reply: In case two different lines are using common multi circuit portion for some distance (originating from different stations, may be terminating on same or on different stations). Two no. 24F OPGW to be installed on both E/W peaks for common M/C portion of 765kV & 400kV lines.

In case 220/132kV lines using multi circuit portion where single E/W peak is available one no. 48F may be installed for common multi circuit portion.



Central Transmission Utility of India Limited



Kallam Transco Limited
1 April 2024

Schedule: 2**Scheduled COD**

[Note: As referred to in the definition of “Element”, “Scheduled COD”, and in Articles 3.1.3 (c), 4.1 (b) and 4.3 (a) of this Agreement]

Sl. No.	Name of the Transmission Element	Scheduled COD	Percentage of Quoted Transmission Charges recoverable on Scheduled COD of the Element of the Project	Element(s) which are pre-required for declaring the commercial operation date (COD) of the respective Element
1.	LILO of both circuits of Parli(M) – Karjat(M)/Lonikand-II (M) 400 kV D/c line (twin moose) at Kallam PS	18 months from date of SPV acquisition	100%	All Elements are required to be commissioned simultaneously as their utilization is dependent on commissioning of each other.
2.	4 Nos. 400 kV line bays at Kallam PS for LILO of both circuits of Parli(M) – Karjat(M)/Lonikand-II(M) 400 kV D/c line (twin moose) at Kallam PS			
3.	63 MVAR, 420 kV switchable line reactor (with NGR bypassing arrangement) on each ckt at Kallam PS end of Karjat – Kallam 400 kV D/c line (~140km.)			

- The payment of Transmission Charges for any Element, irrespective of its successful commissioning on or before its Scheduled COD, shall only be considered after successful commissioning of the Element(s), which are pre-required for declaring the commercial operation date of such Element as mentioned in the above table.

Scheduled COD for the Project is: 18 months from the date of SPV Transfer.

[Note: List of Element(s) along with the critical Element(s) to be provided by CEA]



Schedule: 3**Safety Rules and Procedures**

[Note: As referred to in Articles 5.6 of this Agreement]

1: Site Regulations and Safety:

The TSP shall establish Site regulations within sixty (60) days from fulfilment of conditions subsequent, as per Prudent Utility Practices setting out the rules to be observed till expiry of the Agreement at the Site and shall comply therewith.

Such Site regulations shall include, but shall not be limited to, rules in respect of security, safety of the Project, gate control, sanitation, medical care, and fire prevention, public health, environment protection, security of public life, etc.

Copies of such Site regulations shall be provided to the Nodal Agency and the CEA for the purpose of monitoring of the Project.

2: Emergency Work:

In cases of any emergency, the TSP shall carry out all necessary remedial work as may be necessary.

If the work done or caused to be done by any entity, other than the TSP, the TSP shall, reimburse the actual costs incurred, to the other Party carrying out such remedial works.

3: Site Clearance:

In the course of execution of the Agreement, the TSP shall keep the Site reasonably free from all unnecessary obstruction, storage, remove any surplus materials, clear away any wreckage, rubbish and temporary works from the Site, and remove any equipment no longer required for execution of the Agreement. After completion of all Elements of the Project, the TSP shall clear away and remove all wreckage, rubbish and debris of any kind from the Site, and shall leave the Site clean and safe.

4: Watching and Lighting:

The TSP shall provide and maintain at its own expense all lighting, fencing, and watching when and where necessary for the proper construction, operation, maintenance / repair of any of the Elements of the Project, or for the safety of the owners and occupiers of adjacent property and for the safety of the public, during such maintenance / repair.



Schedule: 4

Computation of Transmission Charges

1.1 General

The Monthly Transmission Charges to be paid to the TSP for providing Transmission Service for any Contract Year during the term of the Agreement shall be computed in accordance with this Schedule and paid as per Sharing Regulations.

Illustration regarding payment of Transmission Charges under various scenarios (considering definitions of Contract Year, Expiry Date & Monthly Transmission Charges above) is as below: -

Illustration-1: In case the Project Elements achieve COD as per Schedule

Quoted Transmission Charges: **Rs. 140 Million**

Completion Schedule:

Element No.	Completion Schedule in Months	Scheduled CoD of the Element	Actual CoD of the Element	% Charges recoverable on Scheduled CoD of the Element
Element 1	28	1-Feb-2018	1-Feb-2018	25%
Element 2	38	1-Dec-2018	1-Dec-2018	75%

Tariff Payable as follows:

Transmission Charges for Element 1			Transmission Charges for Element 2		
1-Feb-18 to 31-Mar-18	140 X 25% X ((28+31)/365)	5.65		--	0.00
1-Apr-18 to 30-Nov-18	140 X 25% X (244/365)	23.39		--	0.00
1-Dec-18 to 31-Mar-19	140 X 100% X (121/365)				46.41
2	140 X 100% X 1				140
3	140 X 100% X 1				140
4	140 X 100% X 1				140
5	140 X 100% X 1				140
.....					
.....					
36 (1-Apr to 30-Nov)	140 X 100% X (244/365)				93.59

Illustration-2: In case of extension of Scheduled COD as per Article 4.4.1 & 4.4.2 of this AgreementQuoted Transmission Charges: **Rs. 140 Million**

Completion Schedule:

Element No.	Completion Schedule in Months	Scheduled CoD of the Element	Actual CoD of the Element	% Charges recoverable on Scheduled CoD of the Element
Element 1	20	1-Feb-2018	1-Jul-2018	25%
Element 2	28	1-Oct-2018	1-Dec-2018	75%

Tariff Payable as follows:

Transmission Charges for Element 1			Transmission Charges for Element 2		
1-Feb-18 to 31-Mar-18	--	0.00		--	0.00
1-Apr-18 to 30-Jun-18	--	0.00		--	0.00
1-Jul-18 to 30-Nov-18	140 X 25% X (153/365)	14.67		--	0.00
1-Dec-18 to 31-Mar-19		140 X 100% X (121/365)			46.41
2		140 X 100% X 1			140
3		140 X 100% X 1			140
4		140 X 100% X 1			140
5		140 X 100% X 1			140
.....					
.....					
36 (1-Apr to 30-Nov)		140 X 100% X (244/365)			93.59

Central Transmission Utility of India Limited



115

Kallam Transco Limited
1 April 2024

Illustration-3: In case of delay in achieving COD of Project & all individual Elements (COD of the Project achieved in Contract Year 1)Quoted Transmission Charges: **Rs. 140 Million**

Completion Schedule:

Element No.	Completion Schedule in Months	Scheduled CoD of the Element	Actual CoD of the Element	% Charges recoverable on Scheduled CoD of the Element
Element 1	20	1-Feb-2018	1-Dec-2018	25%
Element 2	28	1-Oct-2018	1-Dec-2018	75%

Tariff Payable as follows:

Transmission Charges for Element 1			Transmission Charges for Element 2		
1-Feb-18 to 31-Mar-18	--	0.00		--	0.00
1-Apr-18 to 30-Sept-18	--	0.00		--	0.00
1-Oct-18 to 30-Nov-18	--	0.00	1-Oct-18 to 30-Nov-18	--	0.00
1-Dec-18 to 31-Mar-19	140 X 100% X (121/365)				46.41
2	140 X 100% X 1				140
3	140 X 100% X 1				140
4	140 X 100% X 1				140
5	140 X 100% X 1				140
.....					
.....					
36 (1-Apr to 30-Nov)	140 X 100% X (244/365)				93.59



Illustration-4: In case of delay in achieving COD of Project & all individual Elements (COD of the Project achieved in Contract Year other than Contract Year 1)

Quoted Transmission Charges: **Rs. 140 Million**

Completion Schedule:

Element No.	Completion Schedule in Months	Scheduled CoD of the Element	Actual CoD of the Element	% Charges recoverable on Scheduled CoD of the Element
Element 1	38	1-Oct-2019	1-May-2020	25%
Element 2	38	1-Oct-2019	1-May-2020	75%

Tariff Payment to be paid as:

Transmission Charges for Element 1			Transmission Charges for Element 2		
1-Oct-19 to 31-Mar-20	--	0.00	1-Oct-19 to 31-Mar-20	--	0.00
1-Apr-20 to 30-Apr-20	-	0.00	1-Apr-20 to 30-Apr-20	-	0.00
1-May-20 to 31-Mar-21		140 X 100% X (335/365)			128.49
2		140 X 100% X 1			140
3		140 X 100% X 1			140
4		140 X 100% X 1			140
5		140 X 100% X 1			140
.....					
.....					
36 (1-Apr to 30-Apr)		140 X 100% X (30/ 365)			11.51

Illustration5: In case of delay in achieving COD of Element but Project COD achieved on timeQuoted Transmission Charges: **Rs. 140 Million**

Completion Schedule:

Element No.	Completion Schedule in Months	Scheduled CoD of the Element	Actual CoD of the Element	% Charges recoverable on Scheduled CoD of the Element
Element 1	20	1-Feb-2018	1-Jul-2018	25%
Element 2	30	1-Dec-2018	1-Dec-2018	75%

Tariff Payable as follows:

Transmission Charges for Element 1			Transmission Charges for Element 2		
1-Feb-18 to 31-Mar-18	--	0.00		--	0.00
1-Apr-18 to 30-Jun-18	--	0.00		--	0.00
1-Jul-18 to 30-Nov-18	140 X 25% X (153/365)	14.67		--	0.00
1-Dec-18 to 31-Mar-19		140 X 100% X (121/365)			46.41
2		140 X 100% X 1			140
3		140 X 100% X 1			140
4		140 X 100% X 1			140
5		140 X 100% X 1			140
.....					
.....					
36 (1-Apr to 30-Nov)		140 X 100% X (244/365)			93.59



Illustration-6: In case of early commissioning of ProjectQuoted Transmission Charges: **Rs. 140 Million**

Completion Schedule:

Element No.	Completion Schedule in Months	Scheduled CoD of the Element	Actual CoD of the Element	% Charges recoverable on Scheduled CoD of the Element
Element 1	38	1-Oct-2019	1-Jul-2019	25%
Element 2	38	1-Oct-2019	1-Jul-2019	75%

Tariff Payment to be paid as:

Transmission Charges for Element 1		Transmission Charges for Element 2	
1-July-19 to 31-Mar-20	140 X 100% X (274/365)		105.09
2	140 X 100% X 1		140
3	140 X 100% X 1		140
4	140 X 100% X 1		140
5	140 X 100% X 1		140
.....			
.....			
36 (1-Apr to 30-Jun)	140 X 100% X (91/365)		34.91

Illustration-7: In case of early commissioning of an elementQuoted Transmission Charges: **Rs. 140 Million**

Completion Schedule:

Element No.	Completion Schedule in Months	Scheduled CoD of the Element	Actual CoD of the Element	% Charges recoverable on Scheduled CoD of the Element
Element 1	38	1-Oct-2019	1-Apr-2019	25%
Element 2	38	1-Jul-2019	1-Jul-2019	75%

Tariff Payment to be paid as:

Transmission Charges for Element 1			Transmission Charges for Element 2		
1-Apr-2019 to 30-Jun-19	140 X 25% X (91/365)	8.72	1-Apr-2019 to 30-Jun-19	--	0.00
1-July-19 to 31-Mar-20	140 X 100% X (274/ 365)				105.09
2	140 X 100% X 1				140
3	140 X 100% X 1				140
4	140 X 100% X 1				140
5	140 X 100% X 1				140
.....					
.....					
36 (1-Apr-30-Jun)	140 X 100% X (91/365)				34.91

The Transmission Charges shall be payable on monthly basis as computed above.

1.2 Computation of Monthly Transmission Charges

The Monthly Transmission Charges for any month m in a Contract Year n shall be calculated as below:

For AC System:

- a. If Actual Transmission System Availability for the month m of contract year n is greater than or equal to 98% and less than or equal to 98.5%;

$$\text{Monthly Transmission Charges MTC}(m) = T_{mn} * 1$$

Central Transmission Utility of India Limited



120

Kallam Transco Limited



1 April 2024

- a. If Actual Transmission System Availability for the month m of contract year n exceeds 98.5% and less than or equal to 99.75%;

$$\text{Monthly Transmission Charges MTC}(m) = T_{mn} * (AA / 98.5\%)$$

- c. If Actual Transmission System Availability for the month m of contract year n is greater than 99.75%;

$$\text{Monthly Transmission Charges MTC}(m) = T_{mn} * (99.75\% / 98.5\%)$$

- d. If Actual Transmission System Availability for the month m of contract year n is less than 98% and greater than or equal to 95.00%;

$$\text{Monthly Transmission Charges MTC}(m) = T_{mn} * (AA / 98\%)$$

- e. If Actual Transmission System Availability for the month m of contract year falls below 95%;

$$\text{Monthly Transmission Charges MTC}(m) = T_{mn} * (AA / 98\%) - 0.02 * (T_{mn} * (AA / 95\%))$$

For DC System:

- a. If Actual Transmission System Availability for the month m of contract year n is greater than or equal to 95% and less than or equal to 96%;

$$\text{Monthly Transmission Charges MTC}(m) = T_{mn} * 1$$

- b. If Actual Transmission System Availability for the month m of contract year n exceeds 96% and less than or equal to 99.75%;

$$\text{Monthly Transmission Charges MTC}(m) = T_{mn} * (AA / 96\%)$$

- c. If Actual Transmission System Availability for the month m of contract year n is greater than 99.75%;

$$\text{Monthly Transmission Charges MTC}(m) = T_{mn} * (99.75\% / 96\%)$$

- d. If Actual Transmission System Availability for the month m of contract year n is less than 95% and greater than or equal to 92.00%;

$$\text{Monthly Transmission Charges MTC}(m) = T_{mn} * (AA / 95\%)$$

- e. If Actual Transmission System Availability for the month m of contract year falls below 92%;

$$\text{Monthly Transmission Charges MTC}(m) = T_{mn} * (AA / 95\%) - 0.02 * (T_{mn} * (AA / 92\%))$$

where:

Central Transmission Utility of India Limited

121.

Kallam Transco Limited

1 April 2024



Transmission Service Agreement

- AA is the actual Availability, as certified by RPC, as per procedure provided in Schedule 6.
- m is the month in Contract Year 'n'
- T_{mn} = Transmission Charges for the month 'm' in Contract Year 'n' = $(\text{Transmission Charge/ no. of days in the Year n}) * \text{no. of days in month m}$

Provided, no Transmission Charges shall be paid during the period for which the RLDC has not allowed the operation of the Element/Project due to the failure of the TSP to operate it as per the provisions of the Grid Code.

1.3 RLDC Fee & Charges

The payment of RLDC fee & charges, in accordance with relevant regulations of CERC, shall be the responsibility of the TSP.

Central Transmission Utility of India Limited



122

Kallam Transco Limited



1 April 2024

Schedule: 5

Quoted Transmission Charges

[Quoted Transmission Charges from Annexure - 21 of the RFP of the Selected Bidder to be inserted here]

[To be incorporated from the Bid of the Selected Bidder submitted during the e-reverse auction after its selection]

Quoted Transmission Charges: Rs. 152.50 Million

Proportionate Transmission Charges payable for each Element of the Project:

Sl. No.	Name of the Transmission Element	Percentage of Quoted Transmission Charges recoverable on Scheduled COD of the Element of the Project	Element(s) which are pre-required for declaring the commercial operation date (COD) of the respective Element
1.	LILO of both circuits of Parli(M) – Karjat(M)/Lonikand-II (M) 400 kV D/c line (twin moose) at Kallam PS	100%	All Elements are required to be commissioned simultaneously as their utilization is dependent on commissioning of each other.
2.	4 Nos. 400 kV line bays at Kallam PS for LILO of both circuits of Parli(M) – Karjat(M)/Lonikand-II(M) 400 kV D/c line (twin moose) at Kallam PS		
3.	63 MVAR, 420 kV switchable line reactor (with NGR bypassing arrangement) on each ckt at Kallam PS end of Karjat – Kallam 400 kV D/c line (~140km.)		

Central Transmission Utility of India Limited



123

Kallam Transco Limited
1 April 2024



Schedule: 6**Appendix II of the Central Electricity Regulatory Commission (Terms and Conditions of Tariff) Regulations 2019****Procedure for Calculation of Transmission System Availability Factor for a Month**

1. Transmission system availability factor for nth calendar month ("TAFPn") shall be calculated by the respective transmission licensee, got verified by the concerned Regional Load Dispatch Centre (RLDC) and certified by the Member-Secretary, Regional Power Committee of the region concerned, separately for each AC and HVDC transmission system and grouped according to sharing of transmission charges. In case of AC system, transmission System Availability shall be calculated separately for each Regional Transmission System and inter-regional transmission system. In case of HVDC system, transmission System Availability shall be calculated on consolidate basis for all inter-state HVDC system.
2. Transmission system availability factor for nth calendar month ("TAFPn") shall be calculated by consider following:
 - i) **AC transmission lines:** Each circuit of AC transmission line shall be considered as one element;
 - ii) **Inter-Connecting Transformers (ICTs):** Each ICT bank (three single phase transformer together) shall form one element;
 - iii) **Static VAR Compensator (SVC):** SVC along with SVC transformer shall form one element;
 - iv) **Bus Reactors or Switchable line reactors:** Each Bus Reactors or Switchable line reactors shall be considered as one element;
 - v) **HVDC Bi-pole links:** Each pole of HVDC link along with associated equipment at both ends shall be considered as one element;
 - vi) **HVDC back-to-back station:** Each block of HVDC back-to-back station shall be considered as one element. If associated AC line (necessary for transfer of inter- regional power through HVDC back-to-back station) is not available, the HVDC back-to-back station block shall also be considered as unavailable;
 - vii) **Static Synchronous Compensation ("STATCOM"):** Each STATCOM shall be considered as separate element.
3. The Availability of AC and HVDC portion of Transmission system shall be calculated by considering each category of transmission elements as under:



TAFMn (in %) for AC system:

$$= \frac{o \times AV_o + (p \times AV_p) + (q \times AV_q) + (r \times AV_r) + (u \times AV_u)}{(o + p + q + r + u)} \times 100$$

Where,

- o = Total number of AC lines.
 AV_o = Availability of o number of AC lines.
 p = Total number of bus reactors/switchable line reactors
 AV_p = Availability of p number of bus reactors/switchable line reactors
 q = Total number of ICTs.
 AV_q = Availability of q number of ICTs.
 r = Total number of SVCs.
 AV_r = Availability of r number of SVCs
 u = Total number of STATCOM.
 AV_u = Availability of u number of STATCOMs

TAFMn (in %) for HVDC System:

$$= \frac{\sum_{x=1}^s C_{xbp}(\text{act}) \times AV_{xbp} + \sum_{y=1}^t C_{ybtb}(\text{act}) \times AV_{ybtb}}{\sum_{x=1}^s C_{xbp} + \sum_{y=1}^t C_{ybtb}} \times 100$$

Where

- C_{xbp}(act) = Total actual operated capacity of xth HVDC pole
 C_{xbp} = Total rated capacity of xth HVDC pole



AVx _{bp}	=	Availability of x th HVDC pole
C _y btb(act)	=	Total actual operated capacity of y th HVDC back-to-back station block
C _y btb	=	Total rated capacity of y th HVDC back-to-back station block
AV _y btb	=	Availability of y th HVDC back-to-back station block
s	=	Total no of HVDC poles
t	=	Total no of HVDC Back to Back blocks

4. The availability for each category of transmission elements shall be calculated based on the weightage factor, total hours under consideration and non-available hours for each element of that category. The formulae for calculation of Availability of each category of the transmission elements are as per **Appendix-III**. The weightage factor for each category of transmission elements shall be considered asunder:
- For each circuit of AC line – Number of sub-conductors in the line multiplied by ckt-km;
 - For each HVDC pole- The rated MW capacity x ckt-km;
 - For each ICT bank – The rated MVA capacity;
 - For SVC- The rated MVAR capacity (inductive and capacitive);
 - For Bus Reactor/switchable line reactors – The rated MVAR capacity;
 - For HVDC back-to-back station connecting two Regional grids- Rated MW capacity of each block; and
 - For STATCOM – Total rated MVAR Capacity.
5. The transmission elements under outage due to following reasons shall be deemed to be available:
- Shut down availed for maintenance of another transmission scheme or construction of new element or renovation/upgradation/additional capitalization in existing system approved by the Commission. If the other transmission scheme belongs to the transmission licensee, the Member Secretary, RPC may restrict the deemed availability period to that considered reasonable by him for the work involved. In case of dispute regarding deemed availability, the matter may be referred to Chairperson, CEA within 30 days.
 - Switching off of a transmission line to restrict over voltage and manual tripping of switched reactors as per the directions of concerned RLDC.
6. For the following contingencies, outage period of transmission elements, as certified by the Member Secretary, RPC, shall be excluded from the total time of the element under period of consideration for the following contingencies:

Central Transmission Utility of India Limited

126

Kallam Transco Limited

1 April 2024



- i) Outage of elements due to acts of God and force majeure events beyond the control of the transmission licensee. However, whether the same outage is due to force majeure (not design failure) will be verified by the Member Secretary, RPC. A reasonable restoration time for the element shall be considered by Member Secretary, RPC and any additional time taken by the transmission licensee for restoration of the element beyond the reasonable time shall be treated as outage time attributable to the transmission licensee. Member Secretary, RPC may consult the transmission licensee or any expert for estimation of reasonable restoration time. Circuits restored through ERS (Emergency Restoration System) shall be considered as available;
- ii) Outage caused by grid incident/disturbance not attributable to the transmission licensee, e.g. faults in substation or bays owned by other agency causing outage of the transmission licensee's elements, and tripping of lines, ICTs, HVDC, etc. due to grid disturbance. However, if the element is not restored on receipt of direction from RLDC while normalizing the system following grid incident/disturbance within reasonable time, the element will be considered not available for the period of outage after issuance of RLDC's direction for restoration;

Provided that in case of any disagreement with the transmission licensee regarding reason for outage, same may be referred to Chairperson, CEA within 30 days. The above need to be resolved within two months:

Provided further that where there is a difficulty or delay beyond sixty days, from the incidence in finalizing the recommendation, the Member Secretary of concerned RPC shall allow the outage hours on provisional basis till the final view.

7. Time frame for certification of transmission system availability: (1) Following schedule shall be followed for certification of availability by Member Secretary of concerned RPC:

- Submission of outage data by Transmission Licensees to RLDC/ constituents
 - By 5th of the following month;
- Review of the outage data by RLDC / constituents and forward the same to respective RPC – by 20th of the month;
- Issue of availability certificate by respective RPC – by 3rd of the next month.



Appendix-III

FORMULAE FOR CALCULATION OF AVAILABILITY OF EACH CATEGORY OF TRANSMISSION ELEMENTS

For AC transmission system

$$AV_o(\text{Availability of } o \text{ no. of AC lines}) = \frac{\sum_{i=1}^o W_i(T_i - TNA_i)/T_i}{\sum_{i=1}^o W_i}$$

$$AV_q(\text{Availability of } q \text{ no. of ICTs}) = \frac{\sum_{k=1}^q W_k(T_k - TNA_k)/T_k}{\sum_{k=1}^q W_k}$$

$$AV_r(\text{Availability of } r \text{ no. of SVCs}) = \frac{\sum_{i=1}^r W_i(T_i - TNA_i)/T_i}{\sum_{i=1}^r W_i}$$

$$AV_p(\text{Availability of } p \text{ no. of Switched Bus reactors}) = \frac{\sum_{m=1}^p W_m(T_m - TNA_m)/T_m}{\sum_{m=1}^p W_m}$$

$$AV_u(\text{Availability of } u \text{ no. of STATCOMs}) = \frac{\sum_{n=1}^u W_n(T_n - TNA_n)/T_n}{\sum_{n=1}^u W_n}$$

$$AV_{x_{bp}}(\text{Availability of an individual HVDC pole}) = \frac{(T_x - TNA_x)}{T_x}$$

$$AV_{y_{btb}}(\text{Availability of an individual HVDC Back-to-back Blocks}) = \frac{(T_y - TNA_y)}{T_y}$$

For HVDC transmission system

For the new HVDC commissioned but not completed twelve months;

For first 12 months: $[(AV_{x_{bp}} \text{ or } AV_{y_{btb}}) \times 95\% / 85\%]$, subject to ceiling of 95%.

Where,

- o = Total number of AC lines;
 AV_o = Availability of o number of AC lines;
 p = Total number of bus reactors/switchable line reactors;
 AV_p = Availability of p number of bus reactors/switchable line reactors;
 q = Total number of ICTs;
 AV_q = Availability of q number of ICTs;
 r = Total number of SVCs;
 AV_r = Availability of r number of SVCs;
 U = Total number of STATCOM;



Transmission Service Agreement

AV_u	=	Availability of u number of STATCOMs;
W_i	=	Weightage factor for i^{th} transmission line;
W_k	=	Weightage factor for k^{th} ICT;
W_l	=	Weightage factors for inductive & capacitive operation of l^{th} SVC;
W_m	=	Weightage factor for m^{th} bus reactor;
W_n	=	Weightage factor for n^{th} STATCOM.
$T_i, T_k, T_l, T_m, T_n, T_x, T_y$		The total hours of i^{th} AC line, k^{th} ICT, l^{th} SVC, m^{th} Switched Bus Reactor & n^{th} STATCOM, x^{th} HVDC pole, y^{th} HVDC back-to-back blocks during the period under consideration (excluding time period for outages not attributable to transmission licensee for reasons given in Para 5 of the procedure)
$T_{NAi}, T_{NAk}, T_{NAl}, T_{NAM}, T_{NAn}, T_{NAx}, T_{NAy}$		The non-availability hours (excluding the time period for outages not attributable to transmission licensee taken as deemed availability as per Para 5 of the procedure) for i^{th} AC line, k^{th} ICT, l^{th} SVC, m^{th} Switched Bus Reactor, n^{th} STATCOM, x^{th} HVDC pole and y^{th} HVDC back-to-back block.



Schedule: 7

Entire Bid (both financial bid and technical bid) of the Selected Bidder to be attached here

Bids submitted by M/s Indigrd 2 Limited (Lead member) and Indigrd 1 Limited (Other member)- Consortium dated 19.01.2024 shall be integral part of this agreement.

Central Transmission Utility of India Limited



130

Kallam Transco Limited



New Delhi
110003

1 April 2024

Schedule: 8**Contract Performance Guarantee**

(To be on non-judicial stamp paper of appropriate value as per Stamp Act relevant to place of execution. Foreign entities submitting Bids are required to follow the applicable law in their country.)

In consideration of the[Insert name of the SPV or Selected Bidder on behalf of the TSP, or Lead Member in case of the Consortium, with address] agreeing to undertake the obligations under the Transmission Service Agreement datedand the other RFP Project Documents and the Nodal Agency and the[Insert the name of the BPC], agreeing to execute the *RFP Project Documents* with the Selected Bidder, regarding setting up the Project, the [Insert name and address of the bank issuing the guarantee and address of the head office] (hereinafter referred to as "Guarantor Bank") hereby agrees unequivocally, irrevocably and unconditionally to pay to (being the Nodal Agency) at[Insert the Place from the address of the Nodal Agency indicated in the TSA] forthwith on demand in writing from the Nodal Agency or any Officer authorized by it in this behalf, any amount up to and not exceeding Rupees Crores (Rs.) only [Insert the amount of the bank guarantee] on behalf of M/s. [Insert name of the Selected Bidder or SPV].

This guarantee shall be valid and binding on the Guarantor Bank up to and includingand shall not be terminable by notice or any change in the constitution of the Bank or the term of the Transmission Service Agreement or by any other reasons whatsoever and our liability hereunder shall not be impaired or discharged by any extension of time or variations or alternations made, given, or agreed with or without our knowledge or consent, by or between parties to the respective agreement.

Our liability under this Guarantee is restricted to Rs. Crores (Rs.) only. Our Guarantee shall remain in force until [Insert the date of validity of the Guarantee as per Article 3.1.2 of this Agreement]. The Nodal Agency, shall be entitled to invoke this Guarantee up to three hundred sixty five (365) days of the last date of the validity of this Guarantee.

Central Transmission Utility of India Limited

131

Kallam Transco Limited



April 2024

Transmission Service Agreement

The Guarantor Bank hereby expressly agrees that it shall not require any proof in addition to the written demand from (in its roles as the Nodal Agency), made in any format, raised at the above mentioned address of the Guarantor Bank, in order to make the said payment to Nodal Agency.

The Guarantor Bank shall make payment hereunder on first demand without restriction or conditions and notwithstanding any objection by [Insert name of the Selected Bidder], [Insert name of the TSP] and / or any other person. The Guarantor Bank shall not require Nodal Agency to justify the invocation of this BANK GUARANTEE, nor shall the Guarantor Bank have any recourse against Nodal Agency in respect of any payment made hereunder.

THIS BANK GUARANTEE shall be interpreted in accordance with the laws of India.

The Guarantor Bank represents that this BANK GUARANTEE has been established in such form and with such content that it is fully enforceable in accordance with its terms as against the Guarantor Bank in the manner provided herein.

THIS BANK GUARANTEE shall not be affected in any manner by reason of merger, amalgamation, restructuring, liquidation, winding up, dissolution or any other change in the constitution of the Guarantor Bank.

THIS BANK GUARANTEE shall be a primary obligation of the Guarantor Bank and accordingly Nodal Agency shall not be obliged before enforcing this BANK GUARANTEE to take any action in any court or arbitral proceedings against [Insert name of the SPV] or the Selected Bidder, as the case may be, to make any claim against or any demand on [Insert name of the SPV] or the Selected Bidder, as the case may be, or to give any notice to [Insert name of the SPV] or the Selected Bidder, as the case may be, or to enforce any security held by the Nodal Agency or to exercise, levy or enforce any distress, diligence or other process against [Insert name of the SPV] or the Selected Bidder, as the case may be.

The Guarantor Bank acknowledges that this BANK GUARANTEE is not personal to Nodal Agency and may be assigned, in whole or in part, (whether absolutely or by way of security) by Nodal Agency to any entity to whom the Nodal Agency is entitled to assign its rights and obligations under the Transmission Service Agreement.



Transmission Service Agreement

The Guarantor Bank hereby agrees and acknowledges that Nodal Agency shall have a right to invoke this Bank Guarantee either in part or in full, as it may deem fit.

Notwithstanding anything contained hereinabove, our liability under this Guarantee is restricted to Rs. Crores (Rs.) only and it shall remain in force until[Date to be inserted on the basis of Article 3.1.2of the Transmission Service Agreement], with an additional claim period of three hundred sixty five (365) days thereafter. This BANK GUARANTEE shall be extended from time to time for such period, as may be desired by [Insert name of the Selected Bidder or Lead Member in case of the Consortium or SPV]. We are liable to pay the guaranteed amount or any part thereof under this Bank Guarantee only if Nodal Agency serves upon us a written claim or demand.

In witness where of:

Signature

Name:

Power of attorney No.:

For:

..... [Insert Name of the Bank]

Banker's Seal and Full Address, including mailing address of the Head Office



Schedule: 9**Methodology for determining the Relief Under Force Majeure Event & Change in Law during Construction Period**

The relief in the form of revision in tariff due to Force Majeure Event leading to extension of Scheduled COD for a period beyond one hundred eighty (180) days and/ or Change in Law during the construction period shall be as under:

$$\Delta T = [(P \times d)] \div [1 - (1 + d)^{-n}]$$

Where,

ΔT = Change in Transmission Charges for each year

P = Sum of cumulative increase or decrease in the cost of the Project due to Change in Law and interest cost during construction corresponding to the period exceeding one hundred eighty (180) due to Force Majeure Event leading to extension of Scheduled COD for a period beyond one hundred eighty (180) days

n = number of years over which the Transmission Charges has to be paid

d = 7.70 % (Discount rate as notified by the CERC, applicable on the Bid Deadline as per CERC notification dated 05.10.2023).

The increase in Transmission Charges as stated above shall be applicable only if the value of increase in Transmission Charges as calculated above exceeds 0.30% (zero point three percent) of the quoted Transmission Charges of the TSP.



ANNEXURE P/25

SHARE PURCHASE AGREEMENT

BETWEEN

REC POWER DEVELOPMENT AND CONSULTANCY LIMITED

AND

KALLAM TRANSCO LIMITED

AND

INDIGRID 2 LIMITED

AND

INDIGRID 1 LIMITED

Dated: 5th April, 2024





सत्यमेव जयते

INDIA NON JUDICIAL

Government of National Capital Territory of Delhi

₹500

e-Stamp

Certificate No.	: IN-DL68946027781844W
Certificate Issued Date	: 03-Apr-2024 12:43 PM
Account Reference	: SELFPRINT (PU)/ dl-self/ NEHRU/ DL-DLH
Unique Doc. Reference	: SUBIN-DL DL-Self97022345087703W
Purchased by	: REC POWER DEVELOPMENT AND CONSULTANCY LIMITED
Description of Document	: Article 5 General Agreement
Property Description	: CORE-4, SCOPE COMPLEX, 7, LODHI ROAD, NEW DELHI-110003
Consideration Price (Rs.)	: 0 (Zero)
First Party	: KALLAM TRANSCO LIMITED
Second Party	: NOT APPLICABLE
Stamp Duty Paid By	: KALLAM TRANSCO LIMITED
Stamp Duty Amount(Rs.)	: 500 (Five Hundred only)

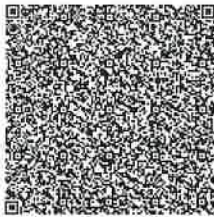

₹500

SELF PRINTED CERTIFICATE TO BE
VERIFIED BY THE RECIPIENT AT
WWW.SHCILESTAMP.COM

IN-DL68946027781844W

Please write or type below this line

SHARE PURCHASE AGREEMENT

This **SHARE PURCHASE AGREEMENT** ('Agreement') made on the 05th day of April, 2024 at New Delhi by and between:

REC POWER DEVELOPMENT AND CONSULTANCY LIMITED, a company incorporated under the Companies Act, 1956, vide CIN-U40101DL2007GOI165779 having its registered office at Core 4, SCOPE Complex, 7, Lodhi Road, New Delhi 110 003, India (hereinafter referred to as "**REC PDCL**", which expression shall, unless it be repugnant to the context or meaning thereof, be deemed to mean and include its successors and permitted assigns) of the **FIRST PART**;

Statutory Alert:

1. The authenticity of this Stamp certificate should be verified at www.shcilestamp.com or using e-Stamp Mobile App of Share Holding. Any discrepancy in the details on this Certificate and as available on the website / Mobile App renders it invalid.
2. **REC PDCL** checking the legitimacy is on the users of the certificate.
3. In case of any discrepancy please inform the Competent Authority.





सत्यमेव जयते

INDIA NON JUDICIAL

Government of National Capital Territory of Delhi

₹500

e-Stamp

Certificate No.	:	IN-DL68938254213133W
Certificate Issued Date	:	03-Apr-2024 12:37 PM
Account Reference	:	SELFPRINT (PU)/ dl-self/ NEHRU/ DL-DLH
Unique Doc. Reference	:	SUBIN-DL DL-Self97006627697905W
Purchased by	:	REC POWER DEVELOPMENT AND CONSULTANCY LIMITED
Description of Document	:	Article 5 General Agreement
Property Description	:	CORE-4, SCOPE COMPLEX, 7, LODHI ROAD, NEW DELHI-110003
Consideration Price (Rs.)	:	0 (Zero)
First Party	:	KALLAM TRANSCO LIMITED
Second Party	:	NOT APPLICABLE
Stamp Duty Paid By	:	KALLAM TRANSCO LIMITED
Stamp Duty Amount(Rs.)	:	500 (Five Hundred only)

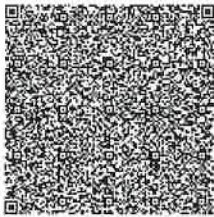

₹500

SELF PRINTED CERTIFICATE TO BE
VERIFIED BY THE RECIPIENT AT
WWW.SHCILESTAMP.COM

IN-DL68938254213133W

Please write or type below this line

AND

KALLAM TRANSCO LIMITED a company incorporated under the Companies Act, 2013 vide CIN- U42202DL2023GOI420108, having its registered office at Core 4, SCOPE Complex, 7, Lodhi Road, New Delhi 110003, India (herein after referred to as "**Company**" which expression shall, unless repugnant to the context, mean and include its successors in interest) of the **SECOND PART**; and



1. The authenticity of this Stamp certificate should be verified at www.shcilestamp.com or using e-Stamp Mobile App of Stock Exchange. Any discrepancy in the details on this Certificate and as available on the website / Mobile App renders it invalid.
2. Checking the legitimacy is on the users of the certificate.
3. In case of any discrepancy please inform the Competent Authority.





सत्यमेव जयते

INDIA NON JUDICIAL

Government of National Capital Territory of Delhi

₹200

e-Stamp

Certificate No. : IN-DL68891676744971W
Certificate Issued Date : 03-Apr-2024 12:01 PM
Account Reference : SELFPRINT (PU)/ dl-self/ NEHRU/ DL-DLH
Unique Doc. Reference : SUBIN-DL DL-SELF96917674958699W
Purchased by : REC POWER DEVELOPMENT AND CONSULTANCY LIMITED
Description of Document : Article 5 General Agreement
Property Description : CORE-4, SCOPE COMPLEX, 7, LODHI ROAD, NEW DELHI-110003
Consideration Price (Rs.) : 0
 (Zero)
First Party : KALLAM TRANSCO LIMITED
Second Party : NOT APPLICABLE
Stamp Duty Paid By : KALLAM TRANSCO LIMITED
Stamp Duty Amount(Rs.) : 200
 (Two Hundred only)

₹200

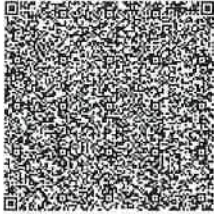

SELF PRINTED CERTIFICATE TO BE
VERIFIED BY THE RECIPIENT AT
WWW.SHCILESTAMP.COM

IN-DL68891676744971W

Please write or type below this line

AND

INDIGRID 2 LIMITED, a company incorporated under the Companies Act, 2013 vide CIN- U29130MH2014PLC353042 and having its registered office at **Unit No. 101, 1st Floor, Windsor, Village Kolekalyan, Off CST road, Vidyanagari Marg, Santacruz (East), Mumbai – 400098, Maharashtra, India**



Statutory Alert

1. The authenticity of this Stamp certificate should be verified at www.shcilestamp.com or using e-Stamp Mobile App of State of India.

2. Any discrepancy in the details on this Certificate and as available on the website / Mobile App renders it invalid.

3. In case of any discrepancy please inform the Competent Authority.

RECPDEL



IG2L

IG1L

INDIGRID 1 LIMITED, a company incorporated under the Companies Act, 1956 vide CIN- U74999MH2005PLC153211 and having its registered office at **UNIT No. 101, 1st Floor, Windsor, Village Kolekalyan, Off CST road, Vidyanagari Marg, Santacruz (East), Mumbai – 400098, Maharashtra, India** (hereinafter individually referred to as “**Partner 1**” and “**Partner 2**” respectively and collectively referred to as “**Selected Bidder**” which expression shall, unless repugnant to the context or meaning thereof, be deemed to mean and include its successors and permitted assigns) of the **THIRD PART**

WHEREAS:

- A. Central Electricity Authority (CEA), Government of India vide its notification no. 560 [F No. CEA-PS-12-13/3/2022-PSPA-II Division] dated 10.08.2023 has notified REC Power Development and Consultancy Limited (RECPDCL) to be the Bid Process Coordinator (BPC) for the purpose of selection of Bidder as Transmission Service Provider (TSP) to establish Transmission System for “**Western Region Network Expansion scheme in Kallam area of Maharashtra**” through tariff based competitive bidding process (hereinafter referred to as the “**Project**”).
- B. In accordance with the Bidding Guidelines, the BPC had initiated a competitive bidding process through issue of RFP for selecting a Successful Bidder to build, own, operate and transfer the Project comprising of the Elements mentioned in **Schedule 2** of the TSA. BPC had initiated this process in accordance with and on the terms and conditions mentioned in the RFP Project Documents (as defined hereinafter).
- C. BPC has incorporated the Company and has undertaken the preliminary studies, obtained certain approvals, etc. regarding the Project on behalf of the Company
- D. REC PDCL along with the Nominees hold one hundred per cent (100%) of the total issued and paid up equity share capital of the Company.
- E. Pursuant to the said Bid Process, IndiGrid 2 Limited (Lead Member with 30% equity contribution) and IndiGrid 1 Limited (Other Member with 70% equity contribution) - Consortium has been identified as the Selected Bidder vide Letter of Intent dated 15th February 2024 issued by the BPC in favour of the Selected Bidder.
- F. As envisaged in the RFP, the Shares Seller (as defined hereinafter) has agreed to sell the Sale Shares (as defined hereinafter) to the Selected Bidder and the Selected Bidder has agreed to purchase the Sale Shares from the Shares Seller, subject to and on the terms and conditions set forth in this Agreement.

NOW THEREFORE, IN CONSIDERATION OF THE MUTUAL COVENANTS AND AGREEMENTS SET FORTH IN THIS AGREEMENT AND FOR OTHER GOOD AND VALUABLE CONSIDERATION, THE PARTIES HEREBY AGREE AS FOLLOWS.



1. DEFINITIONS

- 1.1 Capitalised terms in this Agreement, unless defined in this Agreement shall, in so far as the context admits, have the same meaning in this Agreement as has been ascribed to them in the TSA.
- 1.2 Additionally, the following terms shall have the meaning hereinafter respectively assigned to them herein below:
- (i) **“Acquisition Price”** shall mean INR 6,46,63,522 (Rupees Six Crore Forty-Six Lakhs Sixty-Three Thousand Five Hundred Twenty-Two Only), which is the aggregate consideration payable by the Selected Bidder towards purchase of the Sale Shares at par and for taking over of all assets and liabilities of the Company as on the Closing Date subject to adjustment as per the audited accounts of the Company as on the Closing Date;
 - (ii) **“Agreement”** or **“the Agreement”** or **“this Agreement”** shall mean this Share Purchase Agreement and shall include the recitals and/or annexures attached hereto, and the contracts, certificates, disclosures and other documents to be executed and delivered pursuant hereto, if any, and any amendments made to this Agreement by the Parties in writing;
 - (iii) **“Bid Process”** shall mean the competitive bidding process initiated by the BPC, by issuance of RFP for selecting a Successful Bidder to build, own, operate and transfer the Project in accordance with and on the terms and conditions mentioned in the RFP Project Documents;
 - (iv) **“Board”** shall mean the board of directors of the Company;
 - (v) **“Closing Date”** shall mean a mutually agreed date between the Parties falling within the period as mentioned in clause 2.15.2 of RFP or on failure of such mutual agreement between the Parties shall be the date falling on the last date of such period;
 - (vi) **“Encumbrance”** shall mean any mortgage, pledge, lien, charge, security assignment, hypothecation, trust, encumbrance or any other agreement having the effect of creating security interest;
 - (vii) **“Letter of Intent”** shall have the meaning ascribed thereto under the Bid Documents;
 - (viii) **“Nominees”** shall mean the Persons, who are named in Annexure A of this Agreement, holding the Sale Shares as nominees of REC PDCL;
 - (ix) **“Party”** shall mean REC PDCL, Company and the Selected Bidder, referred to individually, and **“Parties”** shall mean REC PDCL, Company and the Selected Bidder collectively referred to, as relevant;



- (x) “**Person**” shall include an individual, an association, a corporation, a partnership, a joint venture, a trust, an unincorporated organisation, a joint stock company or other entity or organisation, including a government or political subdivision, or an agency or instrumentality thereof, and/or any other legal entity;
- (xi) “**RFP Project Documents**” shall mean the following documents, referred to collectively:
- a. Transmission Service Agreement; and
 - b. this Agreement.
- (xii) “**Representations and Warranties**” shall mean the representations and warranties mentioned in Clause 4 hereto;
- (xiii) “**RoC**” shall mean the Registrar of Companies;
- (xiv) “**Sale Shares**” shall mean 50,000 shares, representing one hundred percent (100%) of the total issued, subscribed and fully paid-up equity share capital of the Company held by the Shares Seller and Nominees as more particularly described in Annexure A attached hereto;
- (xv) “**Shares**” shall mean the fully paid-up equity shares of Company, of face value Rs. 10 each;
- (xvi) “**Shares Seller**” shall mean REC PDCL; and
- (xvii) “**Transmission Service Agreement**” or “**TSA**” means the agreement titled ‘Transmission Service Agreement’ to be executed on 05th April, 2024 between Central Transmission Utility of India Limited (CTUIL) and Kallam Transco Limited, pursuant to which the TSP shall build, own, operate and transfer the Project and make available the assets of the Project on a commercial basis.

1.3 Interpretation Clause

Unless the context otherwise requires, the provisions of the TSA relating to the interpretation of the TSA shall apply to this Agreement as if they were set out in full in this Agreement and to this end are incorporated herein by reference.



2. TRANSFER OF SHARES

- 2.1 Subject to the terms and conditions of this Agreement, the Shares Seller agrees to sell and transfer to the Selected Bidder and the Selected Bidder hereby agrees to purchase from the Shares Seller, the Sale Shares free from Encumbrances together with all assets and liabilities of the Company with rights and benefits attached thereto in consideration of the Acquisition Price and the covenants, undertakings and the agreements of the Selected Bidder contained in this Agreement. The proportion of transfer of Sale Shares to the Selected Bidder shall be as Annexure B of this Agreement.
- 2.2 The Shares Seller hereby undertakes to cause the Nominees to transfer part of the Sale Shares held by them as nominees of the Shares Seller to the Nominees of Selected Bidder and execute any documents required to deliver good title to the Sale Shares to the Selected Bidder.

3. CLOSING

- 3.1 Prior to the Closing Date, the Selected Bidder shall provide to the Shares Seller, valid share transfer forms duly stamped with requisite amount of stamp duty payable on the transfer of the Sale Shares ("**Share Transfer Forms**").
- 3.2 On the Closing Date, the Shares Seller shall hand over to the Selected Bidder or its authorised representative, the original share certificates representing the Sale Shares ("**Sale Share Certificates**") executed by the Shares Seller and the Nominees, simultaneously against the Selected Bidder handing over to the Shares Seller, demand drafts drawn in favour of the Shares Seller or by confirmation of RTGS transfer in favour of the Shares Seller, for the Acquisition Price payable to it.

Provided that prior to the handing over of the Sale Share Certificates to the Selected Bidder as mentioned above, the Selected Bidder shall provide satisfactory evidence to REC PDCL that on the Closing Date, the Selected Bidder has furnished the Contract Performance Guarantee to Central Transmission Utility of India Limited (CTUIL) and is in a position to comply with all other requirements of Clause 2.15.2 of the RFP.

- 3.3 The Selected Bidder shall immediately upon receiving the Sale Share Certificates and the Share Transfer Forms, duly execute the Share Transfer Forms and duly lodge the Share Transfer Forms and the Share Certificates with the Company along with the names of its nominees to be appointed on the Board of the Company and the address within the jurisdiction of the RoC of New Delhi and Haryana, which would be the new registered office of the Company. The Company shall, upon receipt of the said documents from the Selected Bidder, do the following:

- (i) Immediately on the Closing Date convene a meeting of the Board, wherein the Board shall pass the following necessary resolutions:

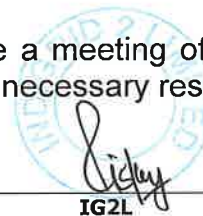

- (a) approving the transfer of the Shares constituting the Sale Shares from the Shares Seller and the Nominees to the name of the **IndiGrid 2 Limited (Lead Member) and IndiGrid 1 Limited (Other Member) - Consortium** and its nominees and transfer of all assets and liabilities of the Company as on Closing Date;
- (b) approving the **IndiGrid 2 Limited (Lead Member) and IndiGrid 1 Limited (Other Member) - Consortium** and its nominees as the members of the Company and entering the name of the **IndiGrid 2 Limited (Lead Member) and IndiGrid 1 Limited (Other Member) - Consortium** and its nominees in the register of members.
- (c) changing the address of the registered office of the Company to the new address as provided by the Selected Bidder as per clause 3.3 above.
- (d) appointing the nominees of the Selected Bidder on the Board and accepting the resignations of the other existing Directors on the Board and the Chair of the meeting which was taken by one of the existing Directors shall be vacated and appointment of a new Chairman who shall be one of the newly appointed Director, for the rest of the meeting.

Immediately pursuant to the acceptance of resignation of the existing Directors and appointment of new Chairman, the newly constituted Board of Directors shall continue with the meeting and pass the following resolution:

- (e) terminating all the authorizations granted regarding the business and/or operations of the Company or the operations of the bank accounts of the Company, with prospective effect; and
- (f) acknowledging and accepting the terms and conditions as contained in the executed copies of the RFP Project Documents and to abide by the provisions contained therein.
- (ii) Enter the name of the **IndiGrid 2 Limited (Lead Member) and IndiGrid 1 Limited (Other Member) - Consortium** and its nominees as the legal and beneficial owner of the Sale Shares, free of all Encumbrances, in the register of members of the Company;
- (iii) Make the necessary endorsements on the Sale Share Certificates, indicating the name of the **IndiGrid 2 Limited (Lead Member) and IndiGrid 1 Limited (Other Member) - Consortium** and its nominees as the legal and beneficial owner of the Sale Shares evidenced there under;



- (iv) Return the original Sale Share Certificates, duly endorsed in the name of the **IndiGrid 2 Limited (Lead Member) and IndiGrid 1 Limited (Other Member) - Consortium** and its nominees, to the **IndiGrid 2 Limited (Lead Member) and IndiGrid 1 Limited (Other Member) - Consortium** and its nominees, as the case may be or its authorized representative;
- (v) Handover all the statutory registers and records, if any, of the Company to the Selected Bidder.
- (vi) Handover certified true copies of the Board resolution passed by the Company as per (i) (a) to (i) (f) of Clause 3.3 (i) to the Central Transmission Utility of India Limited (CTUIL).
- 3.4 The Parties to this Agreement agree to take all measures that may be required to ensure that all the events contemplated in the **Clauses 3.1 to 3.3** above on the Closing Date are completed on the same day.

Notwithstanding the provisions of **Clause 3.3** hereto, all proceedings to be taken and all documents to be executed and delivered by the Parties at the Closing Date shall be deemed to have been taken and executed simultaneously and no proceedings shall be deemed to have been taken nor documents executed or delivered until all have been taken, executed and delivered.

- 3.5 The Selected Bidder hereby acknowledges and agrees that after the date of acquisition of one hundred percent (100%) of the Shares of the Company by the Selected Bidder as per Clause 3.3, (a) the authority of the BPC in respect of the Bid Process shall forthwith cease and any actions to be taken thereafter regarding the Bid Process will be undertaken by the Central Transmission Utility of India Limited (CTUIL) themselves, (b) all rights and obligations of the BPC shall cease forthwith, (c) all other rights and obligations of the Company shall be of the TSP and (d) any decisions taken by the BPC on behalf of the Company prior to the date of acquisition, shall continue to be binding on the Company and/or Central Transmission Utility of India Limited (CTUIL) as the case may be.
- 3.6 This Agreement shall be effective from the date of its signing by the Parties and shall remain in force until all the obligations of the respective Parties under Clause 3.3 hereto are fulfilled.

4. REPRESENTATIONS AND WARRANTIES

- 4.1 The Selected Bidder hereby represents and warrants to the Shares Seller that:



- 4.1.1 The Selected Bidder has full legal right, power and authority to enter into, execute and deliver this Agreement and to perform the obligations, undertakings and transactions set forth herein, and this Agreement has been duly and validly executed and delivered by the Selected Bidder and constitutes its legal, valid and binding obligations, enforceable against it in accordance with its terms;
- 4.1.2 The execution, delivery and performance of this Agreement by the Selected Bidder will not violate or contravene any provision of the Memorandum of Association or Articles of the Selected Bidder, (ii) will not violate or contravene any law, statute, rule, regulation, licensing requirement, order, writ, injunction or decree of any court, governmental instrumentality or other regulatory, governmental or public body, agency or authority by which the Selected Bidder is bound or by which any of its and/or their properties or assets are bound, and (iii) except to the extent that the same have been duly and properly completed or obtained, will not require any filing with, or permit, consent or approval of or license from, or the giving of any notice to, any court, governmental instrumentality or other regulatory, governmental or public body, agency or authority, joint venture party, or any other entity or person whatsoever; and
- 4.1.3 The Selected Bidder is not restricted in any manner whatsoever, including without limitation, on account of any judicial or governmental order, action or proceeding, or any contractual obligation assumed by the Selected Bidder, from purchasing the Sale Shares from the Shares Seller in the manner provided for in this Agreement.
- 4.2 The Shares Seller hereby represents and warrants to the Selected Bidder that;
- 4.2.1 The Shares Seller and the Nominees are the legal and beneficial owners of the Sale Shares, free and clear of any Encumbrance and the delivery to the Selected Bidder of the Sale Shares pursuant to the provisions of this Agreement will transfer to the Selected Bidder a good title to the Sale Shares.
- 4.2.2 The Shares Seller has full legal right, power and authority to enter into, execute and deliver this Agreement and to perform the obligations, undertakings and transactions set forth herein. The execution, delivery and performance of this Agreement will not violate the Memorandum and Articles of Association of the Shares Seller or contravene any contract by which it is bound.
- 4.2.3 The Shares Seller has obtained requisite authorizations to sell and transfer the Sale Shares to the Selected Bidder. The Shares Seller also represent that it is not prevented from transferring and selling the Sale Shares. Also, to the best of its knowledge, the Sale Shares are not the subject matter of any claim or pending proceeding or threatened by any legal proceeding made by any third party.



- 4.3 Except as specified in Clause 4.2 above, the Shares Seller shall not be deemed to have, made any representation or warranty whatsoever, whether express or implied, in relation to the Sale Shares or Company, including but not limited to any implied warranty or representation as to the business or affairs of Company.
- 4.4 The Representations and Warranties are given as at the date of this Agreement except that where a Representation and Warranty is expressed to be made as at another date, the Representation and Warranty is given with respect to that date only.
- 4.5 Each Representation and Warranty is to be construed independently of the others and is not limited by reference to any other Warranty. The Representations, Warranties and undertakings contained in this **Clause 4** hereto or in any document delivered pursuant to or in connection with this Agreement are continuing in nature and shall survive the Closing Date for a period of one (1) year.
- 4.6 The Parties represent to each other that all Representations and Warranties provided herein by the respective Party shall be true as of Closing Date.

5. OBLIGATIONS OF THE SELECTED BIDDER

The Selected Bidder agrees that the Shares Seller shall not be liable in any manner, nor shall it assume any responsibility or liability whatsoever, in respect of the business of the Company and its operations or activities, arising after the Closing Date, to any Person or any authority, central, state, local or municipal or otherwise and the same shall be the sole responsibility of the Selected Bidder.

6. MISCELLANEOUS

6.1 NOTICES

- a) All notices to be given under this Agreement shall be in writing and in the English language.
- b) All notices must be delivered personally or by registered or certified mail or by recognised courier to the addresses below:

Selected Bidder: **IndiGrid 2 Limited**,
Unit No. 101, 1st Floor, Windsor, Village
Kolekalyan, Off CST road, Vidyanagari Marg,
Santacruz (East), Mumbai – 400098,
Maharashtra, India

REC PDCL: **REC Power Development and Consultancy
Limited**
Core-4, SCOPE Complex, 7, Lodhi Road, New
Delhi-110003



Company: **Kallam Transco Limited**
Core-4, SCOPE Complex, 7, Lodhi Road, New Delhi-110003

- c) Any Party may by notice of at least fifteen (15) days to the other Parties change the address and / or addresses to which such notices and communications to it are to be delivered or mailed.

6.2 RESOLUTION OF DISPUTES

6.2.1 If any dispute arises between the Parties, in connection with the validity, interpretation, implementation or alleged breach of any provision of this Agreement ("Dispute"), the disputing Parties hereto shall endeavor to settle such Dispute amicably. The attempt to bring about an amicable settlement shall be considered to have failed if not resolved within sixty (60) days from the date of the Dispute.

6.2.2 If the Parties are unable to amicably settle the Dispute in accordance with Clause 6.2.1 within the period specified therein, any of the Parties shall be entitled to within thirty (30) days after expiry of the aforesaid period, refer the Dispute to the Chief Executive Officer/Director of REC PDCL and Chief Executive/ Managing Director of the Selected Bidder for resolution of the said Dispute. The attempt to bring about such resolution shall be considered to have failed if not resolved within thirty (30) days from the date of receipt of a written notification in this regard.

6.2.3 In the event the Dispute is not settled in accordance with Clause 6.2.2 above, any Party to the Dispute shall be entitled to serve a notice invoking this Clause and making a reference to a sole arbitrator. If the Parties to the Dispute cannot agree as to the appointment of the sole arbitrator within thirty (30) days of receipt of the notice of the Party making the reference, then the Shares Seller along with the Company shall appoint one arbitrator and the Selected Bidder shall appoint one arbitrator and the two arbitrators, so appointed shall appoint a third arbitrator. However, after the Closing Date, in such an event the Shares Seller shall appoint one arbitrator and the Selected Bidder along with the Company shall appoint one arbitrator and the two arbitrators, so appointed shall appoint the third arbitrator.

6.2.4 The place of the arbitration shall be New Delhi. The Arbitration proceedings shall be governed by the Arbitration and Conciliation Act, 1996.

6.2.5 The proceedings of arbitration shall be in English language.

6.2.6 The arbitrator's award shall be substantiated in writing. The arbitrators shall also decide on the costs of the arbitration proceedings. In case the arbitrators have not decided on the costs of the arbitration proceedings, each Party to the Dispute shall bear its own costs in relation to the arbitration proceedings.

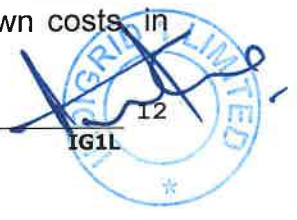

6.3 AUTHORISED PERSON

For the purposes of this Agreement, the Selected Bidder is represented by Mr. Aditya Kislay, pursuant to an authorization granted to Mr. Aditya Kislay through necessary Board resolutions. Further, Mr. Aditya Kislay is also authorized by such resolutions to take any decision which may be required to be taken, do all acts and execute all documents which are or may be required by the Selected Bidder for the proper and effective fulfillment of the rights and obligations under this Agreement. Any action taken or document executed by Mr. Aditya Kislay shall be deemed to be acts done or documents executed by the Selected Bidder and shall be binding on the Selected Bidder.

6.4 RESERVATION OF RIGHTS

No forbearance, indulgence or relaxation or inaction by any Party at any time to require performance of any of the provisions of this Agreement shall in any way affect, diminish or prejudice the right of such Party to require performance of that provision, and any waiver or acquiescence by any Party of any breach of any of the provisions of this Agreement shall not be construed as a waiver or acquiescence of any continuing or succeeding breach of such provisions, a waiver of any right under or arising out of this Agreement or acquiescence to or recognition of rights other than that expressly stipulated in this Agreement.

6.5 CUMULATIVE RIGHTS

All remedies of either Party under this Agreement whether provided herein or conferred by statute, civil law, common law, custom or trade usage, are cumulative and not alternative and may be enforced successively or concurrently.

6.6 PARTIAL INVALIDITY

If any provision of this Agreement or the application thereof to any person or circumstance shall be invalid or unenforceable to any extent, the remainder of this Agreement and the application of such provision to persons or circumstances other than those as to which it is held invalid or unenforceable shall not be affected thereby, and each provision of this Agreement shall be valid and enforceable to the fullest extent permitted by law. Any invalid or unenforceable provision of this Agreement shall be replaced with a provision, which is valid and enforceable and most nearly reflects the original intent of the unenforceable provision.



6.7 TERMINATION

If (i) the Closing does not occur on the Closing Date for any reason whatsoever, or (ii) the Letter of Intent is withdrawn or terminated for any reason, or (iii) due to termination of the TSA by the Central Transmission Utility of India Limited (CTUIL) in accordance with Article 3.3.2 or Article 13 of the TSA thereof, REC PDCL shall have a right to terminate this Agreement forthwith by giving a written notice to the other Parties hereto.

6.8 AMENDMENTS

No modification or amendment of this Agreement and no waiver of any of the terms or conditions hereof shall be valid or binding unless made in writing and duly executed by all the Parties.

6.9 ASSIGNMENT

This Agreement and the rights and liabilities hereunder shall bind and inure to the benefit of the respective successors of the Parties hereto, but no Party hereto shall assign or transfer its rights and liabilities hereunder to any other Person without the prior written consent of the other Parties, which will not be unreasonably withheld.

6.10 ENTIRE AGREEMENT

This Agreement constitutes the entire Agreement between the Parties with respect to the subject matter herein and supersedes and cancels any prior oral or written agreement, representation, understanding, arrangement, communication or expression of intent relating to the subject matter of this Agreement.

6.11 COSTS

Each of the Parties hereto shall pay their own costs and expenses relating to the negotiation, preparation and execution of this Agreement and the transactions contemplated by this Agreement.

The Selected Bidder shall be liable to bear and pay the costs in respect of this Agreement and transfer of Sale Shares.

6.12 RELATIONSHIP

None of the provisions of this Agreement shall be deemed to constitute a partnership between the Parties hereto and no Party shall have any authority to bind the other Party otherwise than under this Agreement or shall be deemed to be the agent of the other in any way.



6.13 GOVERNING LAW AND JURISDICTION

This Agreement shall be governed by and construed in accordance with the laws of India and shall be subject to the exclusive jurisdiction of the courts of Delhi.

6.14 COUNTERPARTS

This Agreement may be executed in counterparts by the Parties and each fully executed counterpart shall be deemed to be original.

6.15 CONFIDENTIALITY

The Parties undertake to hold in confidence and not to disclose the terms and conditions of the transaction contemplated hereby to third parties, except:

- (a) to their professional advisors;
- (b) to their officers, employees, agents or representatives, who need to have access to such information for the proper performance of their activities;
- (c) disclosures required under Law;

without the prior written consent of the other Parties.

Provided that the Central Transmission Utility of India Limited (CTUIL) and REC PDCL may at any time, disclose the terms and conditions of transactions contemplated hereby to any person, to the extent stipulated under the law or the Bidding Guidelines.

6.16 INDEMNIFICATION

The Parties hereby agree that transfer of Sale Shares to the Selected Bidder shall vest all the rights, privileges, licenses, responsibilities, liabilities and other obligations pertaining to the Company in the Selected Bidder.

- The Selected Bidder hereby agrees that the Selected Bidder shall not be entitled to any claims or initiate any legal proceedings by itself or through the Transmission Service Provider against the Shares Seller, its directors, officers, employees and the subscribers including the members of any committees appointed by them in respect of any actions or decisions taken by any of them up to the Closing Date in furtherance of the Project referred to in recital A of this Agreement.
- Further, the Selected Bidder hereby indemnifies and holds harmless at all times the Shares Seller against all past, present and future third party claims and liabilities arising out of actions or decisions taken by any of the persons or bodies referred to in Clause 6.3 up to the Closing Date in furtherance of the Project referred to above or otherwise concerning the

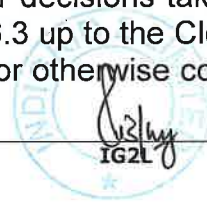

Company. All such actions shall be defended by the Selected Bidder either itself or through the TSP at its own cost.

- The Parties hereby agree that the provisions of this clause shall survive the termination of this Agreement.

6.17 SURVIVAL

The provisions of Clause 1 (Definitions and Interpretation), Clause 4 (Representations and Warranties), Clause 6.2 (Resolution of Disputes), Clause 6.7 (Termination), Clause 6.15 (Confidentiality), Clause 6.16 (Indemnification) and other representations, warranties, covenants and provisions contained herein that by their nature are intended to survive, shall survive the termination of this Agreement

6.18 FORCE MAJEURE

No party shall be liable for its inability or delay in performing any of its obligations hereunder if such delay is caused by circumstances beyond the reasonable control of the party including delay caused through flood, riot, Act of God, lighting civil commotion, storm, tempest and earthquake.

IN WITNESS WHEREOF, THE PARTIES HERETO HAVE CAUSED THIS AGREEMENT TO BE DULY EXECUTED AND DELIVERED AS OF THE DAY AND YEAR FIRST ABOVE WRITTEN



SIGNED AND DELIVERED by the within named **REC POWER DEVELOPMENT AND CONSULTANCY LIMITED** by the hand of Sh. Rajesh Kumar, CEO

(Authorised pursuant to the resolution passed by its Board of Directors in its meeting held on 04th March, 2024)

IN THE PRESENCE OF:

WITNESS:
(Name and address)

1. P.S Hariharan
CAM (Tech)

2. Satyabhan Sahoo
AM (Tech)



[Handwritten signature]

(Core-4, SCOPE Complex,
7, Lodhi Road, New Delhi-110003)

[Handwritten signature]

(Core-4, SCOPE Complex,
7, Lodhi Road, New Delhi-110003)

SIGNED AND DELIVERED by the within named **KALLAM TRANSCO LIMITED** by the hand of Sh. Ajay Mathur, Chairman

(Authorised pursuant to the resolution passed by its Board of Directors in its meeting held on 03rd April, 2024)

WITNESS:
(Name and address)

1. Ritam Biswas
Asst. Manager

2. K. Hausha Vaidhan Kumar
Officer



[Handwritten signature]

(Core-4, SCOPE Complex,
7, Lodhi Road, New Delhi-110003)

[Handwritten signature]

(Core-4, SCOPE Complex,
7, Lodhi Road, New Delhi-110003)



SIGNED AND DELIVERED by The within named **IndiGrid 2 Limited (Lead Member)** by the hand of Mr. Aditya Kislay



(Authorised pursuant to the resolution passed by the Board of Directors in its meeting held on 11th March, 2024)

WITNESS:

(Name and address)

1. MD. WASIM ALAM
SR. MANAGER (B.D & Bidding)

W. Alam

(Unit No. 101, 1st Floor, Windsor, Village Kolkalyan, Off CST road, Vidyanagari Marg, Santacruz (East), Mumbai – 400098, Maharashtra, India)

2. SHIVAM PATHAK
SR. MANAGER

Shivam

(Unit No. 101, 1st Floor, Windsor, Village Kolkalyan, Off CST road, Vidyanagari Marg, Santacruz (East), Mumbai – 400098, Maharashtra, India)

SIGNED AND DELIVERED by The within named **IndiGrid 1 Limited (Other Member)** by the hand of Mr. Puneet Singh Chauhan

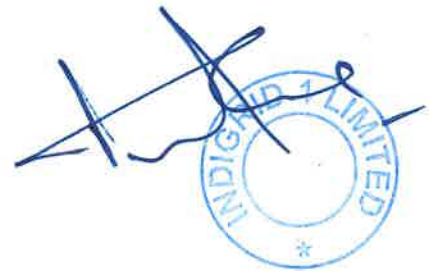

(Authorised pursuant to the resolution passed by the Board of Directors in its meeting held on 11th March, 2024)

WITNESS:

(Name and address)

1. RAJNISH MISHRA
SR. MANAGER

Rajnish

(Unit No. 101, 1st Floor, Windsor, Village Kolkalyan, Off CST road, Vidyanagari Marg, Santacruz (East), Mumbai – 400098, Maharashtra, India)

2. AKHILESH
Akhilesh

Akhilesh

(Unit No. 101, 1st Floor, Windsor, Village Kolkalyan, Off CST road, Vidyanagari Marg, Santacruz (East), Mumbai – 400098, Maharashtra, India)



ANNEXURE A**DESCRIPTION OF THE SALE SHARES**

S. NO.	NAME OF THE SHAREHOLDER	NUMBER OF EQUITY SHARES HELD	PERCENTAGE OF THE TOTAL PAID UP EQUITY CAPITAL
1.	REC POWER DEVELOPMENT AND CONSULTANCY LIMITED through its Chief Executive Officer*	49,994	99.988
2.	Shri Thangarajan Subash Chandira Bosh*	1	0.002
3.	Shri Sahab Narain *	1	0.002
4.	Shri Puthiyarkattu Shivaraman Hariharan*	1	0.002
5.	Shri Alok Singh*	1	0.002
6.	Shri Mohan Lal Kumawat*	1	0.002
7.	Shri Arvind Kumar*	1	0.002
	Total	50,000	100.000

* Held as nominee of REC PDCL.



ANNEXURE B

S. NO.	NAME OF THE SHAREHOLDER	NUMBER OF SHARES	PERCENTAGE OF THE TOTAL PAID UP EQUITY CAPITAL
1.	IndiGrid 1 Limited	35,000	70.000
2.	IndiGrid 2 Limited (IGL2)	14,994	29.988
3.	Ms. Meghana Pandit (As a nominee of IGL2)	1	0.002
4.	Mr. Satish Talmale (As a nominee of IGL2)	1	0.002
5.	Mr. Kundan Kishore (As a nominee of IGL2)	1	0.002
6.	Mr. Urmil Shah (As a nominee of IGL2)	1	0.002
7.	Mr. Giriraj Ajmera (As a nominee of IGL2)	1	0.002
8.	Mr. Ashwin Rajput (As a nominee of IGL2)	1	0.002
	Total	50,000	100.000



BEFORE THE CENTRAL ELECTRICITY REGULATORY COMMISSION,
AT NEW DELHI
PETITION NO. ___/AT/2024
IN THE MATTER OF:

Kallam Transco Ltd.

...Applicant/Petitioner

Versus

REC Power Development and
Consultancy Ltd. & Anr.

...Respondents

VAKALATNAMA

I, Lokendra Singh Ranawat, Son of Shri B.S. Ranawat, aged about 40 years, Authorized Signatory of Kallam Transco Ltd., Applicant/Petitioner herein, having my office at Windsor, 1st Floor, Unit no. 101, Kalina, Santacruz East, Mumbai, Maharashtra 400098, duly authorized thereof, hereby appoint and retain Ms. Aparajita Upadhyay, Advocate to act and appear for us in the above Petition on our behalf to conduct and prosecute (or defend) the same and all proceedings that may be taken in respect of any application connected with the same or any decree or other passed herein, to file and obtain return of documents, and to deposit and receive on my/our behalf in the said Petition and represent me/us and to take all necessary steps on my/our behalf in the above matter. I/We agree to ratify all acts done by the aforesaid Advocate in pursuance of this authority.

Place: Noida

Signature of the Party

Date: 16.04.2024

Executed in my presence.

“Accepted”





Aparajita Upadhyay, Advocate
[Enrollment No. D/3808/2016]

Lokendra Singh Ranawat
Authorized Signatory
Kallam Transco Ltd.

CERTIFIED TRUE COPY OF THE RESOLUTION PASSED BY THE BOARD OF DIRECTORS OF THE COMPANY IN ITS MEETING HELD ON APRIL 05, 2024

License and tariff adoption from Central Electricity Regulatory Commission (CERC)

“RESOLVED THAT the Company do execute the project for “establishment of the Inter-State Transmission System - Western Region Network Expansion scheme in Kallam area of Maharashtra” (hereinafter referred to as “Project”) for the transmission of electricity to be supplied to the Long-Term Transmission Customers awarded to the Company by REC Power Development and Consultancy Limited, the Bid Process Coordinator, appointed by the Ministry of Power.

RESOLVED FURTHER THAT any of the Directors of the Company or Mr. Lokendra Ranawat or Mr. Amit Sabharwal, Authorised Signatory or Mr. Puneet Singh Chauhan, Authorised Signatory (collectively the “Authorised Representatives”) be and are hereby severally authorized to:-

- a) make an application to “Central Electricity Regulatory Commission” (CERC) for grant of License under Electricity Act and Tariff Adoption, approval for creation of security and to execute all necessary applications, documents, undertakings in connection therewith and personally appear before CERC or any other related statutory authority as may be required.
- b) appoint any consultant for representing to CERC.
- c) deal with any Long-Term Transmission Customers or any other statutory agency for the purpose of License and Tariff Adoption.
- d) do all such acts, deeds, matters and things necessary to give effect to this resolution.

RESOLVED FURTHER THAT certified true copy of this resolution duly certified by any of the Directors be given to any regulatory authority including CERC for its records.”

Certified True Copy
For **Kallam Transco Limited**



Amitanshu Srivastava

Director (DIN- 07565361)

Date: 08-04-2024

Address: L-504, Pioneer Park, Sector-61, Ulhawas (83), Badshahpur, Gurgaon, Haryana – 122101